

**University of Kurdistan**

Dept. of Electrical and Computer Engineering

*Smart/Micro Grid Research Center*

[smgrc.uok.ac.ir](http://smgrc.uok.ac.ir)

## **Adaptive load shedding and regional protection**

J.J. Ford, H. Bevrani, G. Ledwich

Published (to be published) in: ***International Journal of Electrical Power & Energy Systems***

(Expected) publication date: **2009**

### **Citation format for published version:**

Ford, Jason J., Bevrani, Hassan, & Ledwich, Gerard (2009) Adaptive load shedding and regional protection. *International Journal of Electrical Power & Energy Systems*, vol. 31(10), pp. 611-618, Nov-Dec 2009

### **Copyright policies:**

- Download and print one copy of this material for the purpose of private study or research is permitted.
- Permission to further distributing the material for advertising or promotional purposes or use it for any profit-making activity or commercial gain, must be obtained from the main publisher.
- If you believe that this document breaches copyright please contact us at [smgrc@uok.ac.ir](mailto:smgrc@uok.ac.ir) providing details, and we will remove access to the work immediately and investigate your claim.



Contents lists available at ScienceDirect

# Electrical Power and Energy Systems

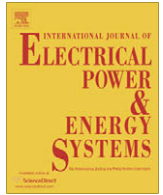
journal homepage: [www.elsevier.com/locate/ijepes](http://www.elsevier.com/locate/ijepes)

## Adaptive load shedding and regional protection

J.J. Ford<sup>a,\*</sup>, H. Bevrani<sup>b</sup>, G. Ledwich<sup>a</sup><sup>a</sup> School of Engineering Systems, Queensland University of Technology, Brisbane, Qld 4001, Australia<sup>b</sup> Department of Electrical and Computer Engineering, University of Kurdistan Sanandaj, Kurdistan, Iran

### ARTICLE INFO

#### Article history:

Received 18 August 2008

Received in revised form 2 April 2009

Accepted 7 June 2009

#### Keywords:

Emergency control

Cascade failure

Inter-region power flow

Load shedding

### ABSTRACT

The requirement for improved efficiency whilst maintaining system security necessitates the development of improved system analysis approaches and the development of advanced emergency control technologies. Load shedding is a type of emergency control that is designed to ensure system stability by curtailing system load to match generation supply.

This paper presents a new adaptive load shedding scheme that provides emergency protection against excess frequency decline, whilst minimizing the risk of line overloading. The proposed load shedding scheme uses the local frequency rate information to adapt the load shedding behaviour to suit the size and location of the experienced disturbance. The proposed scheme is tested in simulation on a 3-region, 10-generator sample system and shows good performance.

© 2009 Elsevier Ltd. All rights reserved.

### 1. Introduction

Increasing economic pressures for power system efficiency and reliability have led to a requirement for the operation of secure power systems closer to their capacity limits [1,2]. Yet, increased utilization of a system's generation and transmission assets tends to decrease system security, and increases the risk of complicated failure mechanisms [1]. Therefore, the requirement for improved efficiency whilst maintaining system security necessitates the development of improved system analysis approaches and the development of advanced emergency control technologies. This paper makes contributions in the last of those areas by proposing a new adaptive load shedding scheme.

Load shedding is an emergency control action designed to ensure system stability by curtailing system load to match generation supply. Typically, load shedding protects against excessive frequency or voltage decline by attempting to balance real and reactive power supply and demand in the system. Typical implementations involve decentralized load shedding control approaches where local shedding decisions, based on local information, are independently made through-out the system, rather than centralized control decisions based on overall system information.

The most common decentralized load shedding schemes are the under frequency load shedding (UFLS) schemes, which involve

shedding predetermined amounts of load if the frequency drops below specified frequency thresholds [3]. Under voltage load shedding (UVLS) schemes, in a similar manner, are used to protect against excessive voltage decline. Various modified UFLS schemes have been promoted in support of improved protection, including: adaptive UFLS schemes that utilized both local frequency and frequency rate information [4,5], dynamic UFLS schemes that dynamically adjust the size of load shed stages [3], and optimized UFLS schemes [6], among others. Unfortunately, the type of protection provided by these schemes is not co-ordinated with other aspects of the power system operation.

Recent cascade failure events have highlighted the importance of the complicated interactions between various aspects of a power system [1,7–11]. These recent events have helped to identify hidden failure and line overloading as two important propagation mechanisms in cascade failure [7–10]. In particular, overloaded lines can contribute to cascade failure through a variety of mechanisms including: increased risk of flashover faults [10,12]; decreased synchronizing power causing transient instability or the unstable growth of small-signal power oscillations [13]; and heavy reactive power flows inducing transient voltage instability [7,10,13]. Similarly, the significant destabilizing influence of zone 3 relays during heavily reactive power loading was demonstrated in the 2003 North American cascade blackout event [1,7,13].

In recent years, numerous avenues for reducing cascade failure risks have been identified, including: general minimization of fault risks [13], the exploitation of flexible AC transmission systems and HVDC links [1,10,13,14], and improved, more co-ordinated emergency controls [1,7,10,13]. In general terms, these suggestions are attempts to improve co-ordination of power system design and

\* Corresponding author. Address: School of Engineering Systems, Queensland University of Technology, 2 George St., GPO Box 2434, Brisbane, Qld 4001, Australia. Tel.: +61 3138 2207; fax: +61 3138 1516.

E-mail addresses: [j2.ford@qut.edu.au](mailto:j2.ford@qut.edu.au), [j2ford@gmail.com](mailto:j2ford@gmail.com) (J.J. Ford), [bevrani@uok.ac.ir](mailto:bevrani@uok.ac.ir) (H. Bevrani), [g.ledwich@qut.edu.au](mailto:g.ledwich@qut.edu.au) (G. Ledwich).

**Nomenclature**

$N_X$ and $N_Y$	number of dynamic and algebraic variables, respectively	$\Delta_{ij}$	power flow constraint between region $i \in N_R$ and region $j \in N_R$
$N_G$ and $N_L$	number of generation and load buses, respectively	$C$	$N_R$ vector of per unit impact factors
$N_R$ and $N_O$	number of power system regions and operating points, respectively	$u_{ls}$ and $u_{ls}^*$	load shedding decision and optimal load shedding decision, respectively
$N_E$	number of generation events requiring protection	$\omega_i^j$	frequency in region $i \in N_R$ at time $t$
$x_t, y_t$ , and $x(i), y(i)$	power system dynamic and algebraic variables (at time $t$ , and at $O^i$ , respectively)	$\omega_{thr} = [\omega_{thr}(1), \dots, \omega_{thr}(M)]$	vector of frequency thresholds
$G_t, G(i), G$ and $G^F$	$N_G$ vectors of inject power (at time $t$ , at $O^i$ , pre and post-fault, respectively)	$\alpha, \omega_{off}$ and $\dot{\omega}_{thr}$	bias rate, threshold bias and major event threshold, respectively
$G^i$ and $G^{if}$	injected powers in region $i$ (pre and post-fault, respectively)	$\dot{\omega}_0$	initial post-contingency frequency rate
$\Delta G^i$	$N_G$ vector of lost generation in event $i \in N_E$	$\omega_{LS}$	earliest load shedding frequency
$L_t, L(i), L$	$N_L$ vectors of load demand (at time $t$ , at $O^i$ , and pre-fault, respectively)	$H$	equivalent inertia constant
$L^i$	load demand in region $i$	$D$	equivalent damping coefficient,
$\Delta L = [\Delta L^1, \dots, \Delta L^{N_E}]$	$N_L$ vector of load shed amounts	$T_{ij}$	tie-line synchronizing coefficient between region $i$ and region $j$
$O^i = [x(i), y(i), G(i), L(i)]$	power system operating points, where $i \in N_O$	$T_g$	governor time constant
$S_{ij} = P_{ij} + jQ_{ij}$	complex power flow between region $i \in N_R$ and region $j \in N_R$	$T_t$	turbine time constant
		$R_i$	droop characteristic

operation to decrease cascade failure risks caused by line overloading and large reactive power transfers. One key example is improved consideration of cascade failure issues in the automatic or manual decisions undertaken during emergency situations.

A renewed investigation of the load shedding for frequency protection is necessary because decentralised load shedding can actually induce temporarily overloaded power lines and/or increase voltage support requirements [10,15]. Although there are many important aspects in the cascade protection problem, we will limit our investigation to load shedding protection of frequency.

Wide-area, or centralized, load shedding approaches appear to be one obvious candidate framework for developing load shedding schemes that offer better co-ordination with other cascade failure considerations [1,5,15–20]. Numerous wide-area load shedding studies have demonstrated the role of disturbance size and location, load shedding size and location, and shed delay time in the effectiveness of load shed actions [7,10,15,17]. However when suitable, local approaches are still desirable due to reliability and cost issues [7].

In this paper, we propose a decentralized load shedding approach that mimics wide-area approaches to provide emergency protection against excess frequency decline but also provides protection against line overloading, and hence minimizes cascade failure risks. A key feature of the proposed load shedding scheme is the use of local frequency rate information to adapt the load shedding behaviour to the size and location of the experienced disturbance. Although frequency rate based load shedding schemes have previously been proposed [5,16], our contribution is novel for two reasons: our use of local frequency rate information to protect wide-area quantities such as inter-region power flows, and the particular manner in which we utilize frequency rate information. The decentralised nature of our proposed approach scales well to large systems.

This paper is organized as follows: In Section 2, a power system dynamic model is introduced and various assumptions are made. In Section 3, a centralized regional constrained load shedding problem is proposed and a solution developed. In Section 4, the key features of the centralized solution are used to motivate a suitable adaptive load shedding scheme for regional protection. In Section

5, simulations studies are provided that demonstrate the performance of our proposed scheme. Finally, in Section 6, some conclusions are made.

**2. Power system dynamics and cascade failure**

In this section, we introduce a modified power system model and introduce a number of definitions and assumptions. We then investigate the effect of load shedding on cascade failure mechanisms.

**2.1. Power system dynamics**

At time  $t$ , consider the following non-linear differential-algebraic equation (DAE) that is an adaptation of the classical representation of power system dynamics [19,20]:

$$\begin{aligned} \dot{x}_t &= f(x_t, y_t, G_t, L_t) \\ 0 &= g(x_t, y_t, G_t, L_t) \end{aligned} \tag{1}$$

where  $x_t$  is a  $N_X$ -dimensional vector containing dynamic variables such as relative rotor angle and angle rate,  $y_t$  is a  $N_Y$ -dimensional vector of algebraic variables such as nodal voltages,  $G_t$  is a  $N_G$ -dimensional vector of the injected power, and  $L_t$  is a  $N_L$ -dimensional vector of demand load. The typical non-linear DAE model often suppresses the dependence on  $G_t$  and  $L_t$ , but we will highlight the role of these disturbance and control variables, respectively, in our problem.

The power system may be required to satisfy a number of additional constraints (such as voltage limits and supply constraints):

$$\begin{aligned} h_i(x_t, y_t) &= 0 \quad \text{for } i = 1, \dots, N_h \\ \bar{h}_j(x_t, y_t) &\leq 0 \quad \text{for } j = 1, \dots, \bar{N}_h \end{aligned} \tag{2}$$

where  $N_h$  and  $\bar{N}_h$  are the number of equality and inequality constraints respectively. Our disturbance and control variables  $G_t$  and  $L_t$  will also be constrained in a number of natural ways (non-negative and non-increasing).

In this paper, we consider frequency protection against the following types of events:

**Definition 2.1** (*A  $N-1$  contingency event*). A  $N-1$  contingency event is an unplanned generation loss event (or equivalent) for which the system is expected to remain stable without the application of an emergency control.

**Definition 2.2** (*A protected event*). A protected event is a large unplanned generation loss event (or equivalent) for which the system is expected to remain stable, perhaps following the application of an emergency control action. For the purposes of this paper, we will also divide protected events into minor protected and major protected events according to the risk of inducing overloaded lines.

The following assumptions will hold through-out the remainder for the paper:

(A1) Without loss of generality, we will assume that each region in the power system can be represented by single machine equivalents [2]. We let  $N_R$  denote the number of regions in a power system and we assume that  $N_G = N_R$  and  $N_L = N_R$ .

(A2) We assume that  $N_O$  candidate operating points  $\{O^i\}$  are provided. Here, for  $i = 1, \dots, N_O$ ,  $O^i = [x(i), y(i), G(i), L(i)]$  is a 4-tuple of quantities, where  $x(i)$  is a  $N_X$ -vector,  $y(i)$  is a  $N_X$ -vector,  $G(i)$  is a  $N_R$ -vector and  $L(i)$  is a  $N_R$ -vector.

(A3) We assume that a list of  $N-1$  contingency events and protected events is provided. For example, we might consider  $N_E$  possible unplanned generation events represented by  $N_R$ -vectors  $\{\Delta G^j\}$  for each  $j = 1, \dots, N_E$ . That is, if operating at  $O^i$  and event  $j$  is experienced, then the post-event generation power supply would become the  $N_R$ -vector  $G^{if} = G^i - \Delta G^j$ .

(A4) We assume that there are no voltage stability issues.

Assumption A4 is the commonly used assumption supporting the use of under frequency load shedding approach on systems without voltage stability issues [3]. Admittedly, the problem of load shedding for voltage stability protection is outside the scope of this study.

We let  $S_{ij} = P_{ij} + jQ_{ij}$  denote the complex power flow between regions  $i$  and  $j$ . Then we define the following additional power system property.

**Definition 2.3** ( *$\Delta$ -Regionally loaded*). Suppose that a set  $\{\Delta_{ij}\}$  of power flow constraints is specified. We will say that the power system is  $\Delta$ -regionally loaded if:

- The system is stable, and
- The inter region power flows are constrained so that  $|S_{ij}| \leq \Delta_{ij}$  for all  $i, j \in [1, \dots, N_R]$ .

## Remarks

1. Assumption A1 is made to simplify presentation and corresponds to an assumption that load shedding decisions can be made on a regional basis. This assumption seems no worse than the assumption typically used to motivate UFLS schemes. For example, in Ref. [6], it is assumed that the whole power system can be represented by a single machine equivalent (a system frequency response model). This assumption is relaxed in later simulation studies.

## 2.2. Cascade failure and line overloads

Emergency control design approaches have typically been based on the assumption that contingency events are rare and have independent probabilities. That is, the possibility of simultaneously contingency events can safely be ignored. However, experiences through-out the world [1] and examinations of historic power system contingency data [11] demonstrate that contingency

probabilities are not independent, and the possibility of multiple contingencies cannot be safely ignored. Cascade failure is one important multiple contingency failure mode that has been emphasized by recent system events [1,7–11].

Unfortunately from a cascade failure perspective, standard UFLS schemes tend to share load shedding responsibilities through-out the system. This sharing behaviour arises as a natural consequence of a power system's tendency to distribute power adjustments through-out the system according to the machine inertias (although the initial impact of any disturbance tends to be initially distributed according to synchronizing power coefficients) [5]. This load sharing behaviour is undesirable from the perspective that overloaded lines have been identified as an important source of the observed cascade failure behaviour [7–9]. In comparison, recently proposed wide-area load shedding scheme have demonstrated that the optimal action is often to rapidly shed load near the source of power imbalance, and hence minimizes the impact on inter region power flows [10,15,17].

This suggests that there are two basic paradigms for load shedding: a shared load shedding paradigm, and a targeted load shedding paradigm. The first paradigm appears in the well-known UFLS schemes, and the second paradigm appears in some recently proposed wide-area load shedding approaches.

Using simulations for a multi-region power system (as shown in Section 5), it is easy to illustrate the difference between these two paradigms, following generation loss in one region. Although both shared and targeted load shedding schemes may be able to stabilize overall system frequency, the shared load shedding response leads to a situation requiring more the power transmission requirements. In some situations, this increased power flow might cause line overloading and increase the risk of cascade failure.

Recalling recent real-world power system serious events demonstrate this fact, clearly. In Australian network, National Electricity Market Management Company (NEMMCO) coordinates the National Electricity Market (NEM) and states that the policy is to share the load shedding requirements. Fig. 1 shows the regional power system frequency and its rate deviations in four region centres following a significant incident on Friday 13th August 2004 in Australia. An equipment failure in New South Wales (NSW) led to the loss of six major electricity generating units in that region, resulting in some customers in NSW, Queensland, Victoria and South Australia losing supply. For this event, approximately 1500 MW of customer load was automatically shed from the system and power was progressively restored within 2.5 h of the incident occurring [21].

Of particular significance, we note that load shedding in Queensland and the resulting increased transfer to NSW almost caused line overload and line trip events. A better load shedding strategy, such as selected load shedding in NSW could have significantly reduced the risk of reaching transfer limits, tripping of more generators and further cascade events. The initial frequency gradient strongly suggests that NSW had the fastest initial acceleration and a biased shedding approach for NSW could be used to significantly increased load shedding in that state. Analysis of this event show that regional load shedding is desirable and feasible and, in this situation, would have limited the peak stresses on interconnections.

## Remarks

1. Sharing load shedding responsibilities (such as induced by UFLS) is not necessarily an undesirable feature and can be justified on a number of grounds. For example, shared load shedding schemes tend to improve the security of the inter-connected regions by allowing generation reserve to be shared. Further, UFLS approaches can be indirectly used to preferentially shed

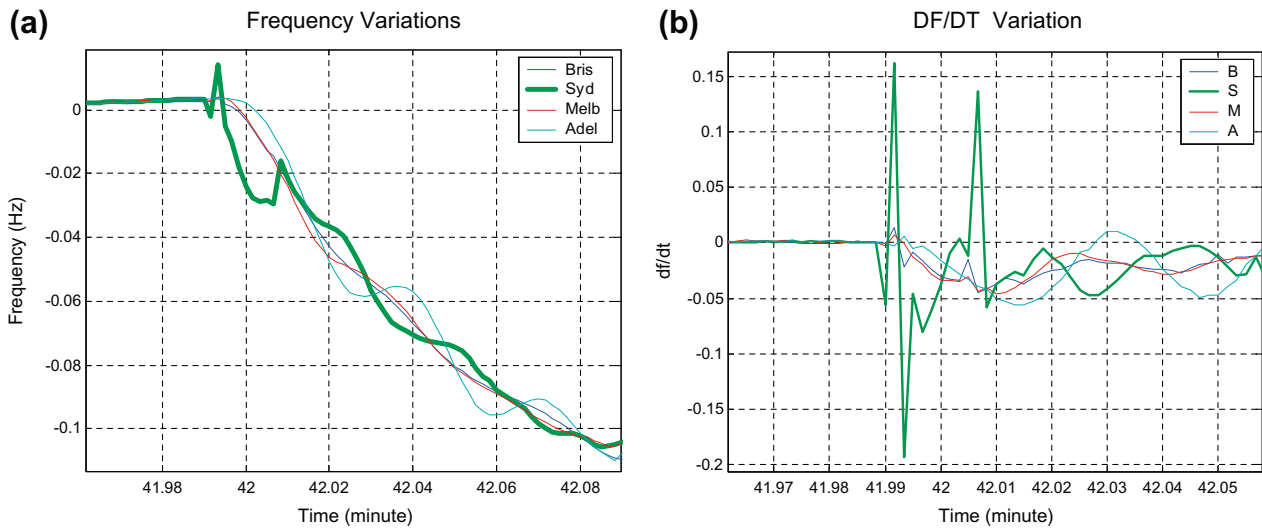

Fig. 1. Regional frequency response following a major protected event (the 13th August event in the main cities Brisbane, Sydney, Melbourne and Adelaide of the affected regions: (a) frequency deviation and (b) frequency gradient.

the least important load in system. However, sharing load shedding can have a significant impact on inter region power flows and, in certain situations, might increase the risk of cascade failure.

- In weakly inter-connected power systems, due to the delay in the propagation of frequency changes through-out the power system, there is some tendency for localization of power adjustments following large events. The size and delays of load shedding actions through the system depends on both the electrical distance and the inertias of the regional generation involved [5].

### 3. Centralized regional-based load shedding

In this section, as a stepping stone, we investigate an idealized optimal centralized load shedding problem for an inter-connected power system. Under our standing assumptions, and ignoring power losses, we consider the power system described by (1) and the following emergency control cost:

$$c(u_{ls}) = \sum_{i=1}^{N_R} C_i \Delta L^i(u_{ls}) \quad (3)$$

subject to the constraint that the system be  $\Delta$ -regionally loaded. Here  $C = [C_1, \dots, C_{N_R}]$  is a vector of per unit impact factors, and  $\Delta L^i(u_{ls})$  is the load change in the region  $i$  following load shedding decision  $u_{ls}$ . These impact factors can be selected to represent the relevant economic factors for the load shedding design problem. We let  $L^i(u_{ls}) = L^i - \Delta L^i(u_{ls})$  denote the new load level in region  $i$ .

This cost function penalizes load shedding decisions in weighted proportion to the amount of load shed, whilst the constraint ensures system stability and no overloading of inter-region power lines. Other representations of the combined stability and power flows objectives are possible (for example, a quadratic penalty on inter region power flow, rather than a constraint on inter region power flow). Alternative representations of load shedding costs are provided in [6], but the additional features in these representations are not important in the context of this paper.

We now propose our centralized regional constrained load shedding control problem. Consider the system dynamics (1) and emergency cost (3). Following a protected event, our optimal centralized load shedding design problem is to determine the load shedding amounts  $\{\Delta L^1, \dots, \Delta L^{N_R}\}$  that minimize the cost (3).

### (b) DF/DT Variation

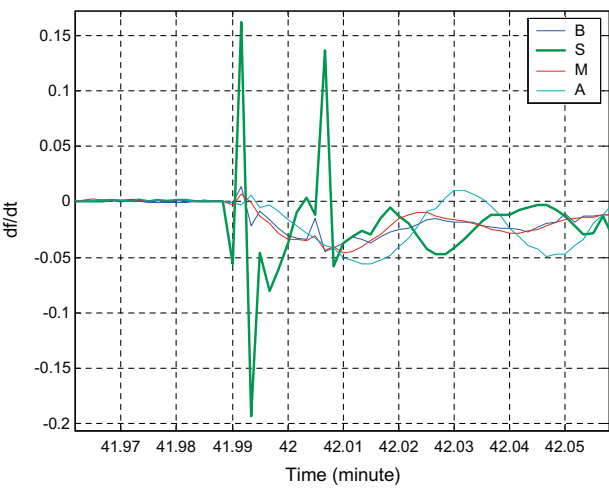

### 3.1. The two-region emergency control problem

We now consider a simplified two-region load shedding problem. Here the  $\Delta$ -regionally load constraint becomes a generation-load balance equation together with a power flow constraint (that is,  $G^1 + G^2 = L^1 + L^2$  and  $|G^1 - L^1| \leq \Delta_{12}$ ), where  $G^i$  is the generation in region  $i$ . That is, ignoring losses, total system generation must equal total system load, and the generation-load imbalance in either region must not exceed the inter-region power flow limits.

Our regionally based emergency control problem is to determine optimal load shed amount  $\Delta L_1(u_{ls})$  and  $\Delta L_2(u_{ls})$  that minimizes customer impact in the sense of achieving

$$\min_{u_{ls}} \{C_1 \Delta L^1(u_{ls}) + C_2 \Delta L^2(u_{ls})\} \quad (4)$$

subject to the  $\Delta$ -regionally loaded constraint:

$$\begin{aligned} G^{1F} + G^{2F} &= L^1(u_{ls}) + L^2(u_{ls}), \\ |G^{1F} - L^1(u_{ls})| &\leq \Delta_{12} \end{aligned} \quad (5)$$

where  $G^{1F}$  and  $G^{2F}$  denote the post-event generation levels. We let  $G^F = G^{1F} + G^{2F}$  denote the total post-event generation and let  $\Delta G^F = (G^1 + G^2) - (G^{1F} + G^{2F})$  denote the total change in system generation.

#### 3.1.1. Optimal solution for two-region problem

This constrained optimization problem has only one degree of freedom, due to our power balance equation:  $\Delta L^1(u_{ls}) = \Delta G^F - \Delta L^2(u_{ls})$ . Further, the linear nature of the cost ensures that if an optimal solution to the constrained problem exists, then a solution can be found at a constraint boundary. Rearrangement of constraints and some algebra gives the following optimal solution.

If load losses in region 2 cause larger customer impact, that is  $C_2 > C_1$ , then an optimal emergency control action,  $u_{ls}^*$ , is given in terms of the optimal load levels as

$$L^1(u_{ls}^*) = \begin{cases} \max\{G^{1F} - \Delta_{12}, 0\} & \text{if } (G^F - L^2) < \max\{G^{1F} - \Delta_{12}, 0\} \\ G^F - L^2 & \text{otherwise} \end{cases} \quad (6)$$

$$\Delta L^2(u_{ls}^*) = \Delta G^F - \Delta L^1(u_{ls}^*) \quad (7)$$



and it also follows that  $\Delta L^1(u_{is}^*) = L^1 - L^1(u_{is}^*)$  and  $\Delta L^2(u_{is}^*) = L^2 - L^2(u_{is}^*)$ .

Alternatively, if load losses in region 1 cause large customer impact, that is if  $C_1 > C_2$ , then an optimal emergency control action,  $u_{is}^*$ , is given in terms of the optimal load levels as

$$L^2(u_{is}^*) = \begin{cases} \max\{G^{2F} - \Delta_{12}, 0\} & \text{if } (G^F - L^1) < \max\{G^{2F} - \Delta_{12}, 0\} \\ G^F - L^1 & \text{otherwise} \end{cases} \quad (8)$$

$$\Delta L^1(u_{is}^*) = \Delta G^F - \Delta L^2(u_{is}^*) \quad (9)$$

Of primary interest, we note that this emergency control load shedding rule exhibits two distinct regions of behaviour. When operating inside the power flow constraints (i.e.  $|G^1 - L^1| \leq \Delta_{12}$ ), then it is optimal to shed the cheapest load. If the power flow constraint is reached (i.e.  $|G^1 - L^1| = \Delta_{12}$ ), then the ability to share load shedding has been reached and the remaining load must be shed in the more expensive region.

#### 4. Decentralized regional load shedding

The above centralized load shedding solution suggests that load shedding schemes that protect inter-region power lines should exhibit three distinct regimes of behaviour. The first regime of desired behaviour is a no load shedding response to  $N-1$  contingencies events. The second regime is a shared load shedding behaviour in response to minor protected events. Finally, the third regime is a targeted load shedding behaviour in response to major protected events (so that changes to inter-region power flows are minimized).

In decentralized approaches the size and location of disturbances is not directly known. However, in [5,16], it is shown that disturbance size is related to the average frequency rate experienced in the system. Moreover, local frequency change is related to the electrical distance from the disturbance [5]. Further, in [10,15], inter-region power requirements are minimized by shedding load near to the source of generation-load imbalance. Together, these three results suggest that local frequency rate information might be useful in targeting load shedding to the disturbance location, and minimizing inter-region power flows.

We use this idea to propose the following adaptive load shedding scheme for regional protection. Let  $\omega_t^i$  denote the local frequency in region  $i$  at time  $t$ , and assume that the power system allows  $M$  fixed blocks of load shedding in each region. Our proposed load shedding algorithm is to shed load block  $j$  in region  $i$ , if at time  $t$

$$\omega_t^i \leq \omega_{thr(j)}, \quad \text{for } j = 1, \dots, M \quad (10)$$

where

$$\omega_{thr(j)} = \min\{\omega_{thr(j)}^0 + \dot{\omega}_{off}, \omega_{LS}\} \quad (11)$$

Here  $\omega_{thr}^0 = [\omega_{thr}^0(1), \dots, \omega_{thr}^0(M)]$  is a vector of UFLS thresholds used to define the load shedding behaviour in response to minor protected events,  $\omega_{LS}$  prevents unnecessary load shedding in response to minor frequency adjustments, and  $\dot{\omega}_{off}$  is an offset used to bias load shedding towards the location of generation-load imbalance, if a major protected event is experienced. Here, the threshold bias  $\dot{\omega}_{off}$  is given by

$$\dot{\omega}_{off} = \begin{cases} \alpha \dot{\omega}_0 & \text{if } \dot{\omega}_0 \geq \dot{\omega}_{thr} \\ 0 & \text{otherwise} \end{cases} \quad (12)$$

where  $\dot{\omega}_0^i$  is the initial post-contingency frequency rate experienced in power system region  $i$ , the gain  $\alpha$  describes the bias rate towards

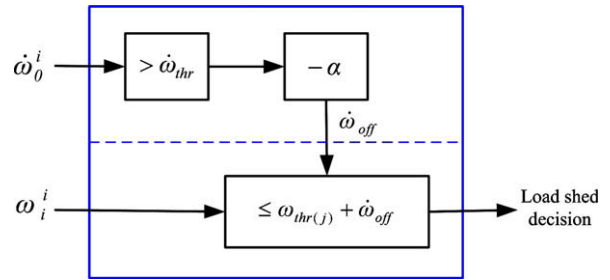

Fig. 2. The proposed regional load shedding scheme.

the location of generation-load imbalance during major protected events, and  $\dot{\omega}_{thr}$  is a major event threshold used to discriminate between minor and major protected events.

Connections with the approach of [5] become apparent when considering the scheme's block diagram shown in Fig. 2. Both schemes involve the use of frequency rate information to modify frequency thresholds. However, the subsumption approach of [5] involves a switch between two sets of threshold values, whilst our approach involves a proportional change to thresholds values driven by the size of the disturbance. Further, our desire to minimize inter-region power flows whilst ensuring stability (rather than an exclusive focus on minimal frequency deviation) motivates our use of threshold adjustments based on initial frequency rates  $\dot{\omega}_0^i$  (rather than the frequency rates  $\dot{\omega}^i$ ).

Acceptable  $\dot{\omega}_0^i$  estimation techniques may be system dependent (for example, may depend on the measurements available), but a reasonable  $\dot{\omega}_0^i$  estimate is the maximum frequency rate within a short time window surrounding a significant frequency excursion event.

##### 4.1. Design of load shedding settings

The three key parameters of the proposed scheme are: the UFLS thresholds  $\omega_{thr(j)}^0$  for  $j = 1, \dots, M$ , the major event threshold  $\dot{\omega}_{thr}$ , and bias gain  $\alpha$ . To simplify this process, it is important to recognize that parameter tuning can be conducted in three stages. The first stage would be the selection of  $\omega_{thr}^0(j)$  by evaluating performance against the  $N-1$  contingencies and minor protected events (in much the same way as existing UFLS settings can be designed). The second stage would be to determine a suitable  $\dot{\omega}_{thr}$  by examining the initial frequency rate experienced by the system in response to a selection of minor and major protected events. In the third and final stage, a suitable  $\alpha$  gain could be determined by variation until the scheme provides suitable protection against major protected events.

A structured design path is based on optimization techniques to determine  $\omega_{thr}^0$  and  $\alpha$ . For example, suitable UFLS settings  $\omega_{thr}^0(j)$  could be determined using an optimization approach such as [6]. Once  $\omega_{thr}^0$  and  $\dot{\omega}_{thr}$  have been selected, a suitable gain  $\alpha$  can be determined using a modification of the optimization approach used to obtain  $\omega_{thr}^0(j)$  settings.

##### Remarks

1. The  $\dot{\omega}_{thr}$  threshold choice delineates load shedding between "shared" and "targeted" behaviours. Hence, this threshold indirectly determines the amount of power importation allowed between connected regions.
2. One attractive feature of the proposed scheme is a natural "robustness" to errors in  $\dot{\omega}_{thr}$  threshold detection. In the event of a  $\dot{\omega}_{thr}$  threshold failure, the system's worst behaviour is either the standard UFLS response or a targeted load shedding outcome and often either outcome is reasonable. In comparison,

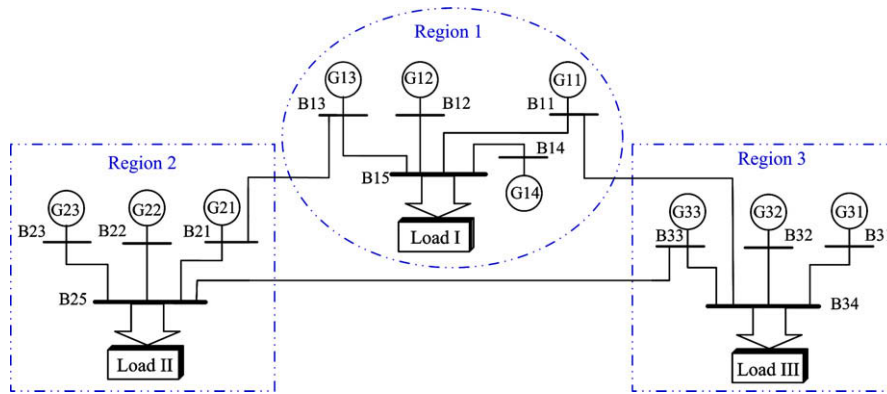

Fig. 3. Block diagram of three region system.

consider the poor system protection provided by fully centralized wide-area load shedding scheme during communication failure.

### 5. Application to a 3-region power system

#### 5.1. Configuration of study system

We now demonstrate our proposed load shedding scheme through simulation studies on a 3-region power system shown in Fig. 3. Each multi-generator region is connected to other two regions. The power system parameters are given in Table 1. It is assumed that our nominal system frequency is 50 Hz and that a frequency decline below  $\omega_{LS} = 49.75$  Hz is required before any load shedding can be triggered.

The presented three region model allows the examination of regional and line overload aspects of load shedding properly. The following additional assumptions are considered:

- During nominal operation there is a 5% generation reserve in each region.
- Turbine-generator units are represented using classical second order model [22] as follows. Here,  $K_i$  is a constant gain. The  $T_{gi}$  and  $T_{ti}$  are governor and turbine time constants, respectively.

$$G_i(s) = \frac{K_i}{(1 + T_{gi}s)(1 + T_{ti}s)} \quad (13)$$

- All generators have primary controllers. Further, it is assumed that there were no voltage stability issues, and that the main system dynamics are sufficiently represented by the rotor dynamics.

#### 5.2. Design of load shedding parameters

In each region, our basic load shedding thresholds were  $\omega_{thr}^0 = [49.75, 49.5, 49.25]$  Hz and the size of load shed blocks was fixed at 0.2 pu. The acceleration threshold was  $\dot{\omega}_{thr} = -1$  and the bias gain was  $\alpha = 0.1$ .

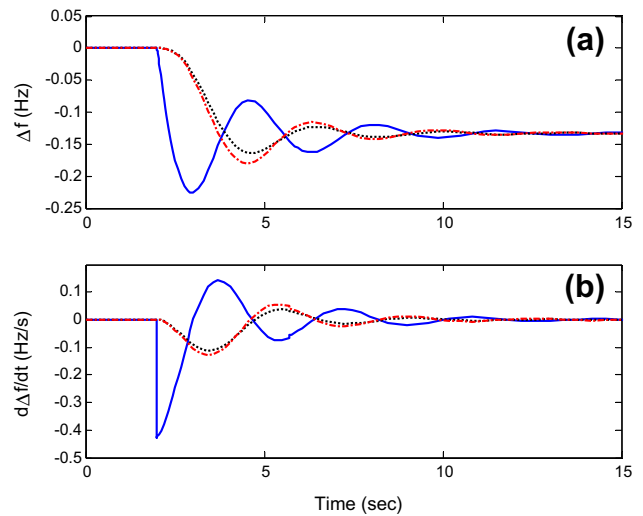

Fig. 4. System response following 0.08 pu step load change in region 1 at 2s: (a) frequency deviation and (b) frequency gradient. Region 1 (solid), region 2 (dotted) and region 3 (dashed-line).

Table 1  
Applied data for simulation.

Regions	Region 1				Region 2			Region 3		
Generator unit	G11	G12	G13	G14	G21	G22	G23	G31	G32	G33
Rating (MW)	1200	600	800	800	600	1200	800	1400	600	600
$H_i$ (s)	6.0	4.0	5.0	5.0	5.0	5.0	4.0	6.0	5.0	5.0
$D_i$ (pu MW/Hz)	0.05	0.08	0.05	0.04	0.05	0.08	0.05	0.07	0.05	0.04
$R_i$ (%)	3.0	3.0	3.2	2.7	2.7	2.6	2.5	2.8	3.0	3.0
$T_{ti}$	0.40	0.36	0.42	0.45	0.44	0.32	0.40	0.30	0.40	0.41
$T_{gi}$	0.30	0.20	0.07	0.10	0.30	0.20	0.15	0.15	0.15	0.20
$K_i$	1.0	1.0	1.0	1.0	1.0	1.0	1.0	1.0	1.0	1.0
$T_{ij}$ (pu/Hz)	$T_{12} = 0.2$ $T_{13} = 0.25$				$T_{21} = 0.2$ $T_{23} = 0.12$			$T_{31} = 0.25$ $T_{32} = 0.12$		

5.3. Simulation results

For the first scenario, the system frequency response is tested following a step loss of generation 0.08 pu at 2s in region 1. The frequency deviation and the corresponded frequency gradient for three regions are shown in Fig. 4. From this figure, it can be concluded that the region's frequency has not passed the first threshold frequency (49.75 Hz). Hence, emergency protection is not triggered and the steady state frequency deviation ( $\Delta f = -0.135$  Hz) must be compensated by load-frequency control (LFC) loops. Since the disturbance occurred in region 1, the higher frequency rate change happens in this region. As has mentioned, the rate of frequency change is proportional to the power imbalance, but is also related to the region system inertia.

As shown in Fig. 5, the frequency changes at all generator terminals within a region are close to each others. Therefore, it is reasonable to neglect differences and assume an averaged frequency (like those shown in Fig. 4) among each region. Fig. 6 shows the total imported power change for each region following the disturbance.

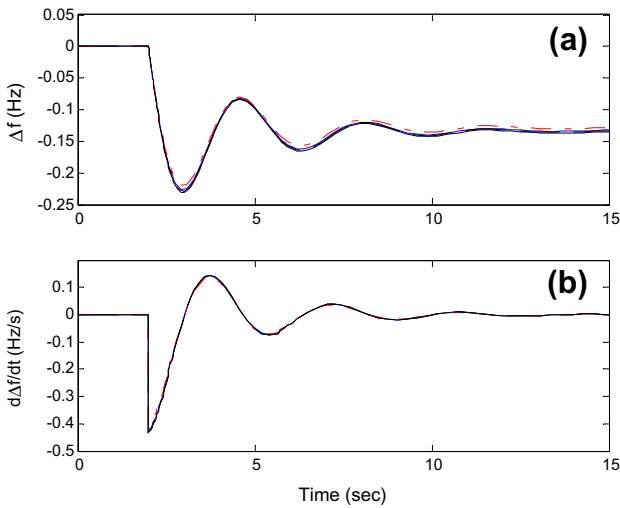

Fig. 5. Frequency response in Region 1, following 0.08 pu step load change at 2s: (a) frequency deviation and (b) frequency gradient. G11 (solid), G12 (dotted), G13 (dashed-line) and G14 (dotted-line).

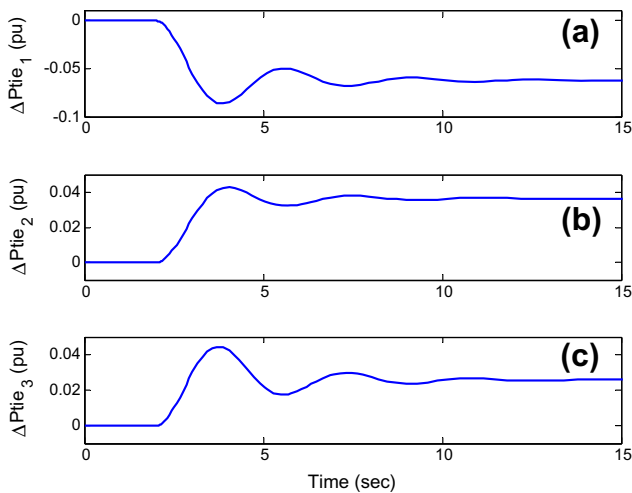

Fig. 6. Inter-region power deviation following 0.08 pu step load change in region 1.

For next scenario, consider the system frequency response following a 0.5 pu load step disturbance (generation loss) in region 1. Here, the total load demand is much higher than the regional power reserve, and, therefore the primary and LFC controls are not able to maintain the frequency at the nominal value. In this scenario, the system is in an emergency condition and load shedding is required to help maintain system frequency. The first load shedding event is triggered at 2.12 s and is quickly followed by a second required load shed event (note that load shedding actions are simulated to occur immediately after passing the relevant frequency thresholds). The system response (frequency deviation, frequency rate change and load shedding in each region) for the proposed load shedding scheme is shown in Fig. 7. Regional imported power changes in each region, following the specified major protected event, are shown in Fig. 8.

In order to illustrate the difference between proposed (targeted) load shedding scheme and conventional (shared) load shedding schemes, the simulation was repeated and these simulation results are shown in Figs. 9 and 10.

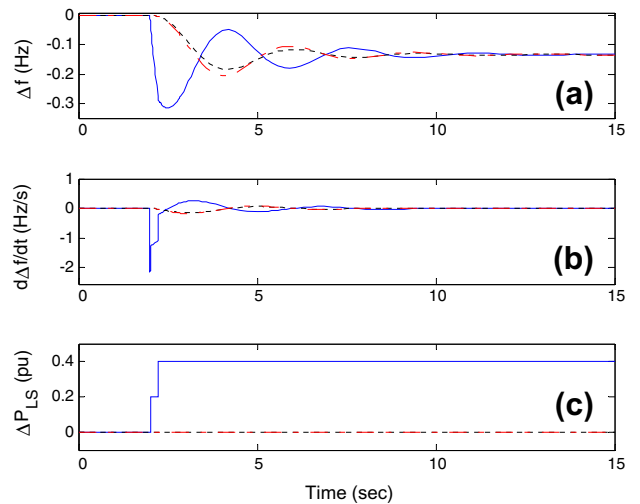

Fig. 7. System response following a major protected event: (a) frequency deviation, (b) frequency gradient and (c) amount of load shedding in each region. Region 1 (solid), region 2 (dotted) and region 3 (dashed-line).

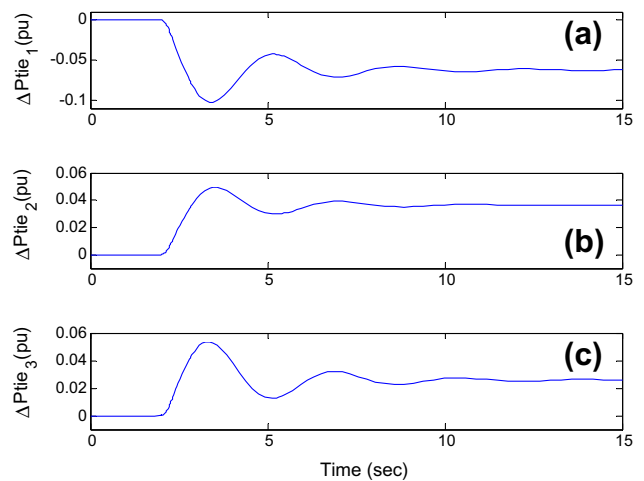

Fig. 8. Regional imported power changes.



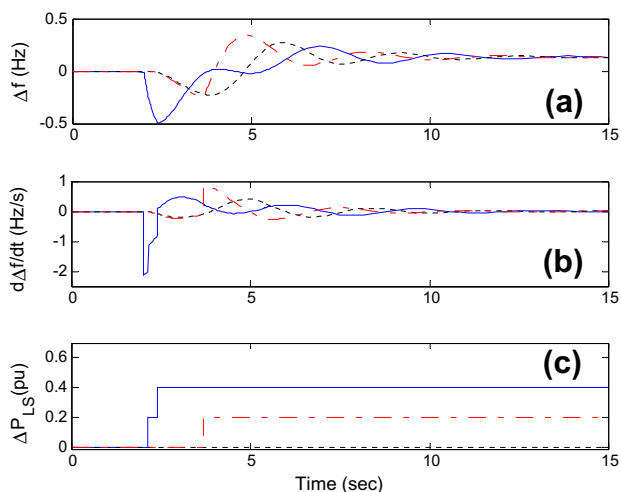

Fig. 9. System response following a major protected event for shared load shedding scheme: (a) frequency deviation (b) and (c) amount of load shedding in each region. Region 1 (solid), region 2 (dotted) and region 3 (dashed-line).

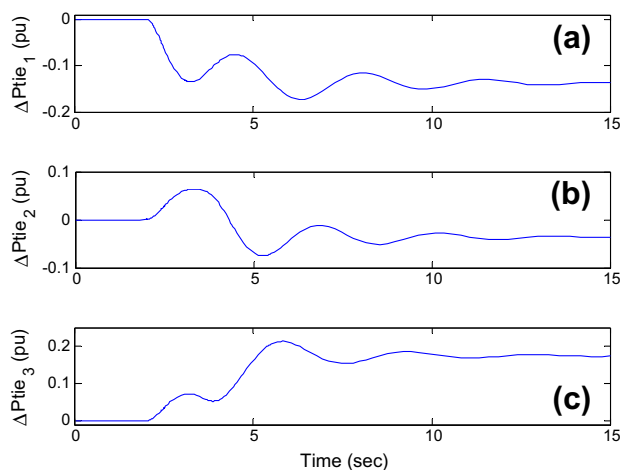

Fig. 10. Regional imported power changes for shared load shedding scheme.

The results shows that both shared and targeted load shedding schemes are able to stabilize the inter-connected power system and stop frequency decline. However, comparison of tie-line power flows in Figs. 8 and 10 shows that to compensate the yield frequency deviation, the shared load shedding response leads to a situation with much larger inter-region power flows. As has mentioned, in certain situations these larger inter-region power flows might cause line overloading, and increase the risk of cascade failure.

## 6. Conclusions

In this paper, a decentralized load shedding approach is proposed. A key feature of the proposed scheme is the use of local frequency rate information to adapt the load shedding behaviour to the size and location of the experienced disturbance. Local frequency rate information is properly used to protect wide-area

quantities such as inter-region power flows, and the particular manner in which we utilize frequency rate information.

The addressed method provides emergency protection not only against excess frequency decline, but also against line overloading, and hence minimizes cascade failure risks. The provided simulation studies on a three control area power system demonstrate the potential benefits of target load shedding compared to more conventional shared load shedding approaches.

## Acknowledgments

This work is supported by Australian Research Council (ARC) under Grant DP0559461.

## References

- [1] Andersson G et al. Causes of the 2003 major grid blackouts in North America and Europe, and recommended means to improve system dynamic performance. *IEEE Trans Power System* 2005;20(4):1922–8.
- [2] Pavella M, Ernst D, Ruiz-Vega D. *Transient stability of power systems: a unified approach to assessment and control*. Boston: Kluwer Academic Publishing; 2000.
- [3] Mohd Zin AA, Mohd Hafiz H, Wong WK. Static and dynamic under-frequency load shedding: a comparison. In: *Int conf on power system tech POWERCON 2004, Singapore, November 2004*. p. 941–45.
- [4] Anderson PM, Mirheydar M. An adaptive method for setting under frequency load shedding relays. *IEEE Trans Power System* 1992;7(2):647–55.
- [5] You H, Vittal V. Self-healing in power systems: an approach using islanding and rate of frequency decline-based load shedding. *IEEE Trans Power System* 2003;18(1):174–81.
- [6] Aik DLH. A general-order system frequency response model incorporating load shedding: analytic modeling and applications. *IEEE Trans Power System* 2006;21(2):709–17.
- [7] Wehenkel L. Emergency control and its strategies. In: *Proc 13th power system comput cont, Trondheim, Norway, 1999*. p. 35–48.
- [8] Kirschen DS. Power system security. *Power Eng J* 2002;16(5):241–8.
- [9] Chen J, Thorp JS, Dobson I. Cascading dynamics and mitigation assessment in power system disturbances via a hidden failure model. *Elect Power Energy System* 2005;27:318–26.
- [10] Novosel D, Begovic MM, Madani V. Shedding lights on blackouts. *IEEE Power Energy Magazine* 2004;2(1):32–43.
- [11] Chen Q, Jiang C, Qiu W, McCalley JD. Probability models for estimating the probabilities of cascading outages in high-voltage transmission network. *IEEE Trans Power System* 2006;21(3):1423–31.
- [12] Bank Tavakoli MR, Vahidi B, Hosseini SH. Discrete-event simulation of the shielding failure of the arrester protected overhead-lines to evaluate risk of flashover. *Int J Elect Power Energy System* 2008;30(10):614–23.
- [13] Pourbeik P, Kundur PS, Taylor CW. The anatomy of a power grid blackout root causes and dynamics of recent major blackouts. *IEEE Power Energy Magazine* 2006;4(5):22–9.
- [14] Basu M. Optimal power flow with FACTS devices using differential evolution. *Int J Elect Power Energy System* 2008;30(2):150–6.
- [15] Shandilya A, Gupta H, Sharma J. Method for generation rescheduling and load shedding to alleviate line overloads using load optimisation. *IEE Proceedings-C* 1993;140(5):337–42.
- [16] Terzija VV. Adaptive under frequency load shedding based on the magnitude of the disturbance estimation. *IEEE Trans Power System* 2006;21(3):1260–6.
- [17] Aponte EE, Nelson JK. Time optimal load shedding for distributed power systems. *IEEE Trans Power System* 2006;21(1):269–77.
- [18] Min Y, Hou K, Zhang R, Tu Q. A new method for generation shedding and load shedding in power system emergency control. In: *Proc IEEE conf elect utility deregulation, restructuring and power technologies (DRPT2004), Hong Kong, April 2004*. p. 210–15.
- [19] De Tuglie E, Dicorato M, La Scala M, Scarpellini P. A corrective control for angle and voltage stability enhancement on the transient time-scale. *IEEE Trans Power System* 2000;15(4):1345–53.
- [20] Bronzini M, Bruno S, De Benedictis M, La Scala M, Bose A. Load shedding scheme for response-based control of transient stability. In: *Proc bulk power system dynamics and control – VI, Italy, August 2004*.
- [21] NEMMCO. Power system incident report – Friday 13 August 2004, NEMMCO, 2005. Available from: <http://www.nemmco.com.au/marketandsystemevents/232-0022.pdf>.
- [22] Saadat H. *Power system analysis*. 2nd ed. Boston: McGraw-Hill; 2002.