



University of Kurdistan

Dept. of Electrical and Computer Engineering

Smart/Micro Grid Research Center

smgrc.uok.ac.ir

A New Intelligent Agent-Based AGC Design With Real-Time Application

Bevrani H, Daneshfar F, Hiyama T

Published (to be published) in: ***IEEE Transaction on Systems, Man, and Cybernetics***

(Expected) publication date: **2012**

Citation format for published version:

Bevrani H, Daneshfar F, Hiyama T (2012) A new intelligent agent-based AGC design with realtime application. *IEEE Transaction on Systems, Man, and Cybernetics, Part C*, vol. 42, pp. 994-1002, Nov 2012 ,DOI: 10.1109/TSMCC.2011.2175916.

Copyright policies:

- Download and print one copy of this material for the purpose of private study or research is permitted.
- Permission to further distributing the material for advertising or promotional purposes or use it for any profit-making activity or commercial gain, must be obtained from the main publisher.
- If you believe that this document breaches copyright please contact us at smgrc@uok.ac.ir providing details, and we will remove access to the work immediately and investigate your claim.

A New Intelligent Agent-Based AGC Design With Real-Time Application

Hassan Bevrani, *Senior Member, IEEE*, Fatemeh Daneshfar, and Takashi Hiyama, *Senior Member, IEEE*

Abstract—Automatic generation control (AGC) is one of the important control problems in electric power system design and operation, and is becoming more significant today because of increasing renewable energy sources such as wind farms. The power fluctuation caused by a high penetration of wind farms negatively contributes to the power imbalance and frequency deviation. In this paper, a new intelligent agent-based control scheme, using Bayesian networks (BNs), is addressed to design AGC system in a multiarea power system. Model independence and flexibility in specifying the control objectives identify the proposed approach as an attractive solution for AGC design in a real-world power system. The BN also provides a robust probabilistic method of reasoning under uncertainty, and moreover, using multiagent structure in the proposed control framework realizes parallel computation and a high degree of scalability. The proposed control scheme is examined on the 10-machine New England test power system. An experimental real-time implementation is also performed on the aggregated model of West Japan power system.

Index Terms—Agent systems, automatic generation control (AGC), Bayesian networks (BNs), intelligent control, wind power generation.

I. INTRODUCTION

CURRENTLY, wind is the fastest growing and most widely utilized renewable energy technology in power systems. The wind turbine generators have attracted an accelerated attention in recent years. Nowadays, due to the interconnection of more distributed generators, especially wind turbines, the electric power industry has become more complicated than ever. Since the primary energy source (wind) cannot be stored and is uncontrollable, the controllability and availability of wind power significantly differ from conventional power generation [1]. In most power systems, the output power of wind turbine generators varies with wind speed fluctuation, and this fluctuation results into frequency variation [2]. Some reports have recently addressed the power system frequency control issue, in the presence of wind turbines [3]–[9].

Manuscript received January 24, 2011; revised August 9, 2011; accepted November 2, 2011. This work was supported in part by Frontier Technology for Electrical Energy funded by Kyushu Electric Power Company, Japan under Grant B-10404022. This paper was recommended by Associate Editor R. W. Brennan.

H. Bevrani and F. Daneshfar are with the Department of Electrical and Computer Engineering, University of Kurdistan, Sanandaj 66177-15175, Iran (e-mail: bevrani@iee.org; f_daneshfar@yahoo.com).

T. Hiyama is with the Department of Electrical and Computer Engineering, Kumamoto University, Kumamoto 860-8555, Japan (e-mail: hiyama@cs.kumamoto-u.ac.jp).

Color versions of one or more of the figures in this paper are available online at <http://ieeexplore.ieee.org>.

Digital Object Identifier 10.1109/TSMCC.2011.2175916

The conventional automatic generation control (AGC) designs are usually suitable for working at specific operating points, and they are not more efficient for modern power systems, considering increasing size, changing structure, emerging renewable energy sources, and new uncertainties. Most of the conventional AGC synthesis methodologies provide model-based controllers that are difficult to use for large-scale power systems with nonlinearities and uncertain parameters. On the other hand, most of the applied linear modern/robust control techniques to the AGC problem suggest complex control structure with high-order dynamic controllers, which are not practical for industry practices [10]. Therefore, it is expected that using intelligent AGC schemes in new environment to be more adaptive/flexible than conventional ones, and is going to become an appealing approach. Over the years, several intelligent control techniques are used for the frequency regulation/AGC issue in the power systems; however, there are just few reports on the intelligent frequency control design in the presence of wind power units [8], [9]. This paper addresses a new intelligent methodology using Bayesian network (BN)-based multiagent control scheme to satisfy AGC objectives concerning the integration of wind power units.

The BN is known as a powerful tool for knowledge representation and inference in control systems with uncertainties and undefined dynamics [11]. They have been successfully applied in a variety of real-world engineering tasks, but they have received little attention in the area of power system control issues. The main feature of the BN is in the possibility of including local conditional dependences into the model, by directly specifying the causes that influence a given effect [12].

In this paper, the proposed BN-based multiagent AGC framework includes two agents in each control area to estimate the amount of power imbalance and provide an appropriate control action signal according to the load disturbances and tie-line power changes. In comparison of multiagent reinforcement learning (MARL)-based AGC design which has been already proposed by the authors in [8] and [13], the present control framework provides more simplicity in AGC design and more flexibility in AGC operation. A major merit of the BNs over many other types of predictive and learning models, such as reinforcement method, is in the possibility of representing the interrelationships among the dataset attributes.

To demonstrate the efficiency of the proposed control method, some nonlinear simulations on the New England 10-machine 39-bus test system, concerning the integration of wind power units, are carried out. A real-time laboratory experience on the aggregated model of West Japan power system (WJPS) is performed using the analog power system simulator (APSS) in the Re-

search Laboratory, Kyushu Electric Power Company, Japan. The results show that the proposed AGC scheme guarantees the optimal performance for a wide range of operating conditions.

This paper is organized as follows: A brief introduction on the BNs is given in Section II. The AGC system with wind farms (WFs) is discussed in Section III. In Section IV, the proposed intelligent BN-based multiagent AGC scheme is presented. The BNs construction and parameter learning are explained in Section V. Simulation results and laboratory experiment are provided in Section VI; discussion is given in Section VII, and, finally, the paper is concluded in Section VIII.

II. BAYESIAN NETWORKS

The BNs show a way to find the probability of future outcomes as a function of available data and current inputs. The BNs are able to handle incomplete datasets, allow one to learn about the causal relationships between different variables, and to make predictions in the presence of interventions. Since the BNs are based on learning methods, they are independent of environment conditions and can consider all kind of environment disturbances. Therefore, the BN approaches are not model based and are easily scalable for large-scale systems, such as real-world power systems.

A BN is a graphical model that efficiently encodes the joint probability distribution for a large set of variables. In the probabilistic graphical models, the nodes represent random variables, and the arcs represent conditional independence assumptions between variables. For independent variables, there is no arc between two nodes. The arcs' pattern presents the graph structure. Hence, it provides a compact representation of joint probability distributions. For example, for N binary variables, an atomic representation of the joint $p(x_1, \dots, x_n)$ needs $O(2^n)$ parameters, whereas a graphical model may need exponentially fewer, depending on which conditional assumptions are considered [12].

In a BN, an arc from A to B can be informally interpreted as indicating that A "causes" B (or B is dependent to A); in this structure, A is the parent node of B and B is the child node of A . A BN consists of 1) an acyclic graph S ; 2) a set of random variables $x = \{x_1, \dots, x_n\}$ (the graph nodes) and a set of arcs that determines the nodes (random variables) dependences; and 3) a conditional probability table (CPT) associated with each variable ($p(x_i|pa_i)$). Together, these components define the joint probability distribution for x . The nodes in S are in one-to-one correspondence with the variables x . In this structure, x_i denotes a variable and its corresponding node, and pa_i represents the parents of node x_i in S , as well as the variables corresponding to those parents. The lack of possible arcs in S encodes conditional independences. In particular, given a structure S , the joint probability distribution for x is defined by

$$p(x_1, \dots, x_n) = \prod_{i=1}^n p(x_i | pa_i) \quad (1)$$

For technical review, see [11] and [12].

III. AUTOMATIC GENERATION CONTROL WITH WIND FARMS

The impact of WFs on the dynamic behavior of power system may cause a different system frequency response to a disturbance event. Since the system inertia determines the sensitivity of overall system frequency, it plays an important role in this consideration. A lower system inertia leads to faster changes in the system frequency following a load-generation imbalance. The addition of synchronous wind generation to a power system intrinsically increases the system inertial response [8], [10].

The impact of WFs on power system inertia is a key factor in investigating the power system AGC behavior in the presence of high penetration of wind power generation. To analyze the additional variation caused by wind turbines, the total effect is important, and every change in wind power output does not need to be matched one for one by a change in another generating unit moving in the opposite direction. However, the slow wind power fluctuation dynamics and total average power variation negatively contribute to the power imbalance and frequency deviation, which should be taken into account in the well-known AGC control scheme.

The conventional AGC model is well discussed in [10] and [14]. To generalize the conventional model, the updated area control error (ACE) signal should represent the impacts of wind power on the scheduled flow over the tie lines. The ACE signal is traditionally defined as a linear combination of frequency and tie-line power changes as follows [14]:

$$ACE = \beta \Delta f + \Delta P_{\text{tie}} \quad (2)$$

where Δf is the frequency deviation, β is the frequency bias, and ΔP_{tie} is the difference between the actual (act) and scheduled (sched) power flows for a given area with m tie lines

$$\Delta P_{\text{tie}} = \sum_{j=1}^m (P_{\text{tie,act}_j} - P_{\text{tie,sched}_j}). \quad (3)$$

For a considerable amount of wind (W) power, its impact must be also considered with conventional (C) power flow in the overall area tie-line power. Therefore, the updated ΔP_{tie} can be expressed as follows:

$$\begin{aligned} \Delta P_{\text{tie}} &= \Delta P_{\text{tie-C}} + \Delta P_{\text{tie-W}} \\ &= \sum_{j=1}^m (P_{\text{tie-C,act}_j} - P_{\text{tie-C,sched}_j}) \\ &\quad + \sum_{j=1}^m (P_{\text{tie-W,act}_j} - P_{\text{tie-W,estim}_j}). \end{aligned} \quad (4)$$

Using (2) and (4), an updated ACE signal can be completed as

$$\begin{aligned} ACE &= \beta \Delta f + \sum_{j=1}^m (P_{\text{tie-C,act}_j} - P_{\text{tie-C,sched}_j}) \\ &\quad + \sum_{j=1}^m (P_{\text{tie-W,act}_j} - P_{\text{tie-W,estim}_j}) \end{aligned} \quad (5)$$

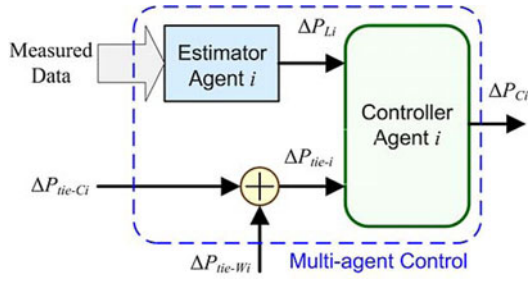
 Fig. 1. Proposed BN-based multiagent control for area i .

where $P_{\text{tie-}C,\text{act}}$, $P_{\text{tie-}C,\text{sched}}$, $P_{\text{tie-}W,\text{act}}$, and $P_{\text{tie-}W,\text{estim}}$ are actual conventional tie-line power, scheduled conventional tie-line power, actual wind tie-line power, and scheduled wind tie-line power, respectively.

IV. PROPOSED INTELLIGENT CONTROL SCHEME

A. Control Framework

The overall view of the proposed control framework for typical area i is conceptually shown in Fig. 1. The control unit in each area presents two agents: 1) An *estimator agent* to estimate amount of load change; and 2) an intelligent BN-based *controller agent* to provide an appropriate supplementary control action signal. The objective of the proposed design is to regulate the frequency and tie-line power concerning the integration of wind power units with various load disturbances and achieve a desirable control performance.

The two-agent scheme entailed a minimum number of measurement/monitoring and control activities in a control area to track the AGC tasks. The controller agent uses ΔP_{tie} and load demand change ΔP_L signals to provide the control action signal ΔP_C . The estimator agent is responsible to estimate amount of load change.

B. Bayesian Network Structure

To find a clear view of the BN structure in the AGC synthesis, it is better to start by determining of the necessary variables for modeling. This initial task is not always straightforward. As a part of this task, one should: 1) correctly identify the modeling objective; 2) investigate important relevant observations; 3) determine what subset of those observations is worthwhile to model; and, finally, 4) organize the observations into variables having mutually exclusive and collectively exhaustive states.

In the process of a BN construction for AGC issue, the aim is to achieve the AGC objective and keep the ACE signal within a small band around zero using the supplementary control action signal. Then, the query variable in the posterior probability distribution is ΔP_C signal, and the posterior probabilities according to possible observations are relevant to the AGC problem.

There are many observations that are related to the AGC problem; however, the best one that has the least dependence to the model parameters and causes the maximum impact on the frequency deviation and, consequently, ACE signal changes are load disturbance and tie-line power deviation signals. Then, the appropriate posterior probability that should be found is $p(\Delta P_C | \Delta P_{\text{tie}}, \Delta P_L)$.

The ΔP_{tie} can be practically obtained using measurement instruments. However, the ΔP_L is one of the input parameters that is not directly measurable, but it can be easily estimated using a numerical/analytical method [10]. A simple method to estimate the amount of load change following a load disturbance is discussed in the next section. This estimation method is initially based on the measured frequency gradient and the specified system characteristics. Considering the AGC duty cycle (timescale), the total consumed time that is needed for the estimation process is not significant.

C. Estimation of Amount of Load Change

As mentioned, the estimator agent estimates the total power imbalance (amount of load change sensed in control area, ΔP_L) by an assigned algorithm based on the following analytical method. Consider the i th generator swing equation for a control area with N generators ($i = 1, \dots, N$)

$$2H_i \frac{d\Delta f_i(t)}{dt} + D_i \Delta f_i(t) = \Delta P_{m_i}(t) - \Delta P_{L_i}(t) = \Delta P_{d_i} \quad (6)$$

where ΔP_{m_i} is the mechanical power, ΔP_{L_i} is the load demand (electrical power), H_i is the inertia constant, D_i is the load damping, and ΔP_{d_i} represents the load-generation imbalance. By adding N generators within the control area, one obtains the following expression for the total load-generation imbalance:

$$\Delta P_D(t) = \sum_{i=1}^N \Delta P_{d_i}(t) = 2H \frac{d\Delta f(t)}{dt} + D\Delta f(t). \quad (7)$$

Equation (7) shows the multimachine dynamic behavior by an equivalent single machine. Using the concept of an equivalent single machine, a control area can be represented by a lumped load generation model using an equivalent frequency Δf , system inertia H , and system load damping D [10]

$$\Delta f = \Delta f_{\text{sys}} = \frac{\sum_{i=1}^N (H_i \Delta f_i)}{\sum_{i=1}^N H_i} \quad (8)$$

$$H = H_{\text{sys}} = \sum_{i=1}^N H_i, \quad D = D_{\text{sys}} = \sum_{i=1}^N D_i. \quad (9)$$

The magnitude of total load-generation imbalance ΔP_D , after a while, can be obtained from (7)

$$\Delta P_D = D\Delta f \quad (10)$$

where

$$\Delta P_D = \Delta P_m - \Delta P_L - \Delta P_{\text{tie}} \quad (11)$$

$$\Delta P_m = \sum_{i=1}^N P_{m_i}, \quad \Delta P_L = \sum_{i=1}^N P_{L_i}. \quad (12)$$

and ΔP_{tie} is defined in (4). The total mechanical power change indicates the total power generation change due to governor action, which is in proportion to the system frequency deviation [14]

$$\Delta P_m \cong \Delta P_g = -\frac{1}{R_{\text{sys}}} \Delta f. \quad (13)$$

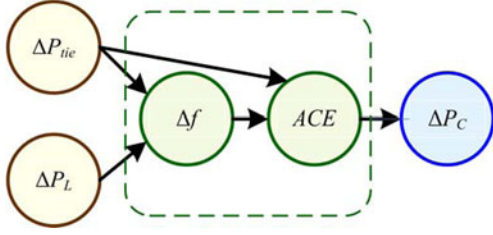

Fig. 2. Graphical model for an area.

Equations (10), (11), and (13) give

$$\Delta P_L = -\left(\frac{1}{R_{sys}} + D\right) \Delta f - \Delta P_{tie}. \quad (14)$$

Thus, the total load change in a control area is proportional to the system frequency deviation. Neglecting the network power losses, $\Delta P_D(t)$ shows the load-generation imbalance proportional to the total load change. Using (7), the magnitude of total load-generation imbalance immediately after the occurrence of disturbance at $t = 0^+$ s can be expressed as follows:

$$\Delta P_D = 2H_{sys} \frac{d\Delta f}{dt}. \quad (15)$$

Equations (11) and (15) give

$$\Delta P_L = \Delta P_m - 2H_{sys} \frac{d\Delta f}{dt} - \Delta P_{tie} \quad (16)$$

where Δf is the frequency of the equivalent system. To express the result into a suitable form for sampled data, (16) can be represented in the following difference equation:

$$\Delta P_L(T_S) = \Delta P_m(T_S) - \frac{2H_{sys}}{T_S} [\Delta f_1 - \Delta f_0] - \Delta P_{tie}(T_S) \quad (17)$$

where T_S is the sampling period. Δf_1 and Δf_0 are the system equivalent frequencies at t_0 and t_1 (the boundary samples within the assumed interval), respectively. To find more detail on the load change estimation, see [10].

V. IMPLEMENTATION METHODOLOGY

A. Bayesian Network Construction

After determining the most worthwhile subset of the observations (ΔP_{tie} , ΔP_L), in the next phase of the BN construction, a directed acyclic graph that encodes assertion of conditional independence is built. It includes the problem random variables, nodes' conditional probability distribution, and nodes' dependences.

The basic structure of the needed graphical model for the AGC issue, which is shown in Fig. 2, is built based on the prior knowledge of the problem. According to (2), since the ACE signal is dependent on the frequency and tie-line power deviations, they will be the parent nodes of the ACE signal (control input) in the BN graphical model, and since frequency deviation is dependent on the load disturbance and tie-line power deviation, they will be parent nodes of Δf . Since ΔP_C as the controller output is considered to be dependent on the ACE signal only, ACE node is the parent node for the control action signal.

Using the ordering (ΔP_{tie} , ΔP_L , Δf , ACE, and ΔP_C) and according to Fig. 2, the conditional dependences are described as follows:

$$\begin{aligned} p(\Delta P_L | \Delta P_{tie}) &= p(\Delta P_L) \\ p(\Delta P_{tie} | \Delta P_L) &= p(\Delta P_{tie}) \\ p(\Delta f | \Delta P_L, \Delta P_{tie}) &= p(\Delta f | \Delta P_L, \Delta P_{tie}) \\ p(ACE | \Delta P_{tie}, \Delta P_L, \Delta f) &= p(ACE | \Delta P_{tie}, \Delta f) \\ p(\Delta P_C | ACE, \Delta P_{tie}, \Delta P_L, \Delta f) &= p(\Delta P_C | ACE). \end{aligned} \quad (18)$$

In a BN, the aim is to find the probability distribution of the graphical model nodes from training data (parameter learning) and, then, do inference task according to the observation. In the graphical model, each node has a probability table and nodes with parents have CPTs (because they are dependent to their parents). The graphical model of the AGC problem (see Fig. 2) is based on the right side of the described relationships in (18).

In the next step of the BN construction (parameter learning), the local conditional probability distributions $p(x_i | p a_i)$ must be computed from the training data. Probability and conditional probability distributions related to the AGC issue, according to Fig. 2, are $p(\Delta P_L)$, $p(\Delta P_{tie})$, $p(\Delta f | \Delta P_L, \Delta P_{tie})$, $p(ACE | \Delta P_{tie}, \Delta f)$, and $p(\Delta P_C | ACE)$. To find these probabilities, the training data matrix should be provided.

Here, BNs toolbox (BNT) [15] is used for probabilistic inference of the model. The BNT uses the training data matrix and finds the conditional probabilities that are related to the graphical model variables (as the parameter learning phase). Once a BN is constructed (from prior knowledge, data, or a combination), various probabilities of interest from the model can be determined [16]. For the problem at hand, it is desired to compute the posterior probability distribution on a set of query variables, given the observation of another set of variables called evidence. The posterior probability that should be found is $p(\Delta P_C | \Delta P_{tie}, \Delta P_L)$. This probability is not stored directly in the model, and, hence, needs to be computed. In general, the computation of a probability of interest, given a model, is known as *probabilistic inference*.

B. Parameter Learning

As shown in the graphical model of a control area (see Fig. 2), the essential parameters that are used for the learning phase among each control area of a power system can be considered as ΔP_{tie} , ΔP_L , Δf , ACE, and ΔP_C . In order to find a related set of training data (ΔP_{tie} , ΔP_L , Δf , ACE, ΔP_C) for the sake of parameter learning phase, one can provide a long-term simulation for the considered power system case study in the presence of various disturbance scenarios. This large learning set is partly complete and it can be used for parameter learning issue in the power system with a wide range of disturbances. Since the BNs are based on inference and new cases (that may not include in the training set) can be inferred from the training table data, it is not necessary to repeat the learning phase of the system for different amounts of disturbances occurred in the system.

After providing the training set, the training data related to control areas are given to the BNT separately. The BNT uses the input data and do the parameter learning phase for

each control area's parameters. It finds prior and conditional probability distribution related to that area's parameters, i.e., $p(\Delta P_L)$, $p(\Delta P_{tie})$, $p(\Delta f|\Delta P_L, \Delta P_{tie})$, $p(ACE|\Delta P_{tie}, \Delta f)$, and $p(\Delta P_C|ACE)$. Following completing the learning phase, the power system simulation will be ready to run and the proposed model uses inference phase to find an appropriate control action signal ΔP_C for each control area.

During simulation stage, the inference phase is done as follows: At each time step, corresponding controller agent of each area gets the input parameters (ΔP_{tie} , ΔP_L) of the model, and digitizes them for the BNT (the BNT does not work with continuous values). The BNT finds the posterior probability distribution values $p(\Delta P_C|\Delta P_{tie}, \Delta P_L)$ related to each area. Then, the controller agent finds the maximum posterior probability distribution from the return set, and gives the most probable evidence ΔP_C in the control area.

VI. APPLICATION RESULTS

In order to illustrate the effectiveness of the proposed intelligent control strategy, it is first examined on the well-known New England 10 generators, 39-bus system as a test case study. Then, an experimental real-time application on the aggregated model of WJPS is explained. The results in both test systems are compared with the application of MARL AGC approach which is presented by authors in [8] and [13].

A. New England Test System

The New England test system is widely used as a standard system for testing of new power system analysis and control synthesis methodologies. This system has 10 generators, 19 loads, 34 transmission lines, and 12 transformers. The test system is updated by adding two WFs in buses 5 and 21. A single-line diagram of the updated system with simulation parameters is given in [8]. The system is divided into three areas. There are 198.96 MW of conventional generation, 22.67 MW of wind power generation, and 265.25-MW load in Area 1. In Area 2, there are 232.83 MW of conventional generation and 232.83-MW load. In Area 3, there are 160.05 MW of conventional generation, 22.67 MW of wind power generation, and 124.78 MW of load.

In this study, similar to the real-world power systems, it is assumed that conventional generation units are responsible to provide spinning reserve for the sake of load tracking and the AGC task. However, it is assumed that only one generator in each area is responsible for the AGC task: G1 in Area 1, G9 in Area 2, and G4 in Area 3. For the sake of simulation, random variations of wind velocity have been considered. Dynamics of wind turbines, including the pitch angle control of the blades, are also considered [1]. The startup and rated wind velocity for the WFs are specified as about 8.16 and 14 m/s, respectively. Furthermore, the pitch angle controls for the wind blades are activated only beyond the rated wind velocity. The pitch angles are fixed to 0° at a lower wind velocity below the rated one.

In the performed application, the important inherent requirement and basic constrains, such as governor dead band and generation rate constraint, that are imposed by physical system

TABLE I
TRAINING DATA MATRIX FOR AREA i

Time (sec)	ΔP_{tie-i} (pu)	ΔP_{L-i} (pu)	Δf_i (Hz)	ACE_i (pu)	ΔP_{C-i} (pu)
0.005	0.03	0.1	-0.01	0.02	-0.08
...

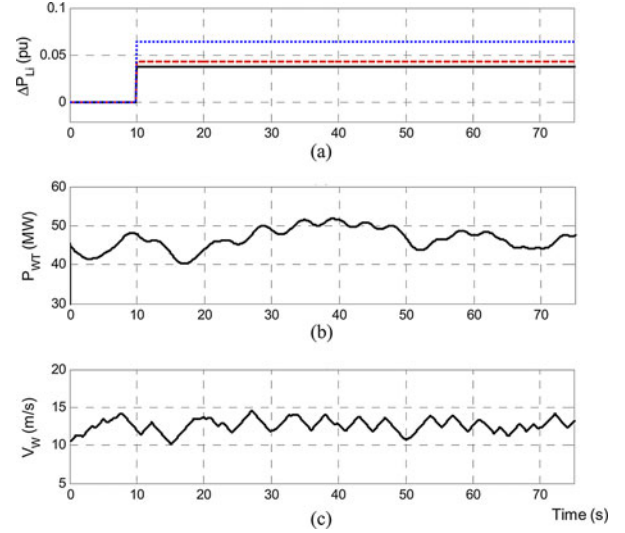

Fig. 3. (a) Load step disturbances in three areas. (b) Total Wind power. (c) Wind velocity pattern in Area 1.

TABLE II
RETURNED POSTERIOR PROBABILITY DISTRIBUTION VALUES
FROM BNT FOR AREA i

$p(\Delta P_{C-i} \Delta P_{tie-i}, \Delta P_{L-i})$	0.005	0.1	0.032	0	...
ΔP_{C-i} (pu)	-0.08	0.03	0.1	-0.005	...

dynamics are considered. For the sake of simulation, three step load disturbances are simultaneously applied to the three areas: 3.8% of total area load at bus 8 in Area 1, 4.3% of total area load at bus 3 in Area 2, and 6.4% of total area load at bus 16 in Area 3. Using the simulation, the training table rows can be built in a format that is shown in Table I. The applied step load disturbances ΔP_{L-i} (p.u.), the output power of WFs P_{WT} (megawatt), and the wind velocity V_w (meter/second) are shown in Fig. 3. The impact of wind power fluctuation on the system frequency for the same test system is, comprehensively, discussed in [8] and [18].

A simple presentation of probability tables using the proposed graphical model (see Fig. 2), according to the training data, after parameter learning phase for the test system is shown in Table IV (see Appendix). Some samples of returned posterior probability distribution values $p(\Delta P_C|\Delta P_{tie}, \Delta P_L)$ from BNT environment are also shown in Table II. The frequency deviation Δf and ACE signals of the closed-loop system are shown in Figs. 4 and 5, respectively. According to the returned posterior probabilities distribution values, the control action signals for three control areas are shown in Fig. 6. The fast movements in wind power output are combined with movements in load and other resources, and it is seen that the power system response is affected by the wind power fluctuation.

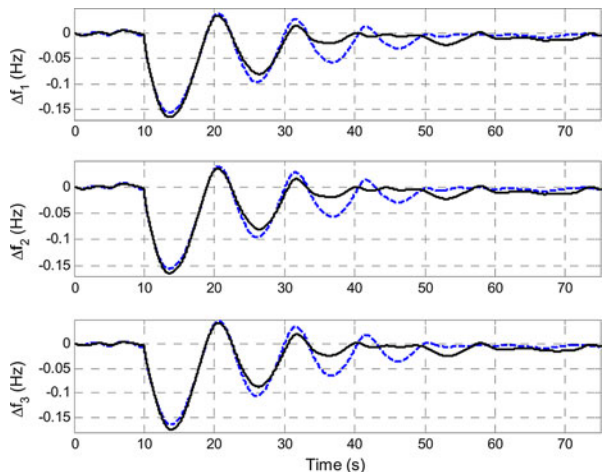

Fig. 4. Frequency deviation. Proposed multiagent BNs method (solid line) and MARL method (dashed line).

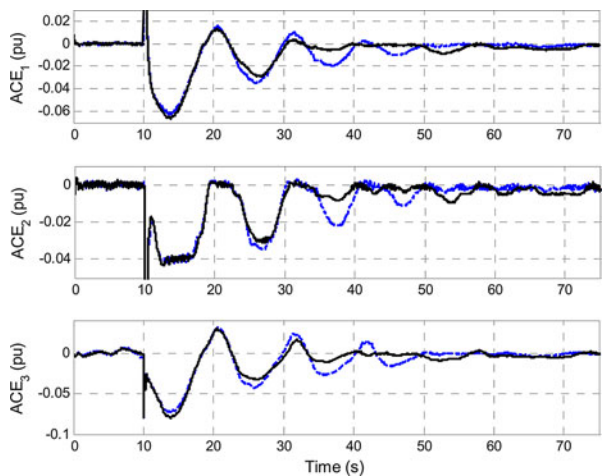

Fig. 5. ACE signal. Proposed multiagent BNs method (solid line) and MARL method (dashed line).

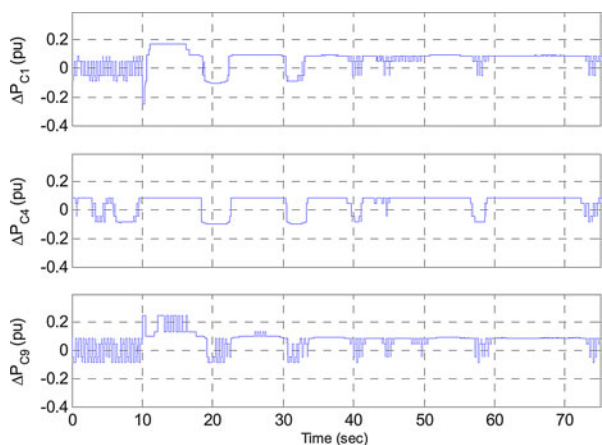

Fig. 6. Control action curves for the AGC participating units using the proposed multiagent BNs design.

It is shown that using the proposed method, the ACE and frequency deviations in all areas are properly driven close to zero in the presence of wind turbines and load disturbance.

TABLE III
PERFORMANCE EVALUATION

AGC Scheme	$ ACE_1 _{ave} (pu)$	$ ACE_2 _{ave} (pu)$	$ ACE_3 _{ave} (pu)$
BN-based	0.0039	0.0040	0.0047
MARL-based	0.0060	0.0058	0.0070

The average of $|ACE_i|$ over 5 min is used as a performance index, and the results for the proposed adaptive control scheme and MARL design are listed in Table III. It is shown in [8] that the MARL design presents greater performance than the conventional proportional-integral (PI)-based AGC systems. Therefore, in comparison with the existing conventional AGC system, the closed-loop performance of the present BN-based multiagent scheme is, significantly, improved.

B. Real-Time Laboratory Experiment

Since the AGC as a supplementary control is known as a long-term control problem (few seconds to several minutes [10]), it is expected that the proposed AGC methodology to be successfully applicable to the real-world power systems.

To illustrate the capability of the proposed control strategy in real-time AGC applications, an experimental study has been performed on the large-scale APSS in the Research Laboratory, Kyushu Electric Power Company. For the purpose of this study, a longitudinal four-machine infinite bus system representing the WJPS network is considered to be the test system. A single line diagram of the study system is shown in Fig. 7(a). All generator units are thermal type, with separately conventional excitation control systems. The set of four generators represents a control area (Area I), and the infinite bus is considered to be other connected systems (Area II). The detailed information of the system and the parameters of each generator unit and its associated turbine system (including the high-pressure, intermediate-pressure, and low-pressure parts) are given in [17]. Although in the given model the number of generators is reduced to four, it closely represents the dynamic behavior of the WJPS.

The whole power system [shown in Fig. 7(a)] has been implemented using the APSS. Fig. 7(b) shows an overview of the applied laboratory experiment devices including the generator panels, monitoring displays, and control desk. The proposed control scheme, including estimator and controller agents, has been built in a personal computer connected to the power system using a DSP board equipped with A/D and D/A converters. The converters act as the physical interfaces between the personal computer and the analog power system hardware.

The performance of the closed-loop system is tested in the presence of load disturbances. The nominal area load demands are also fixed at the same values given in [17]. Almost 10% of total demand power is supplied by the installed WF in bus 9. For the first scenario, the power system is tested following a step load increase of 0.06 p.u. The participation factors for Gen 1, Gen 2, Gen 3, and Gen 4 are fixed at 0.4, 0.25, 0.20, and 0.15, respectively. The applied step disturbance and the closed-loop system response including frequency deviation Δf and tie-line power change ΔP_{tie} are shown in Fig. 8. This figure shows that

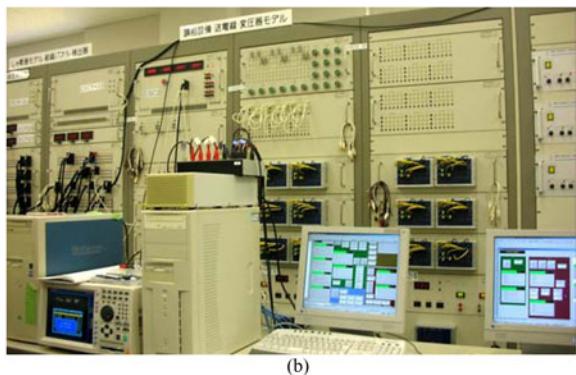
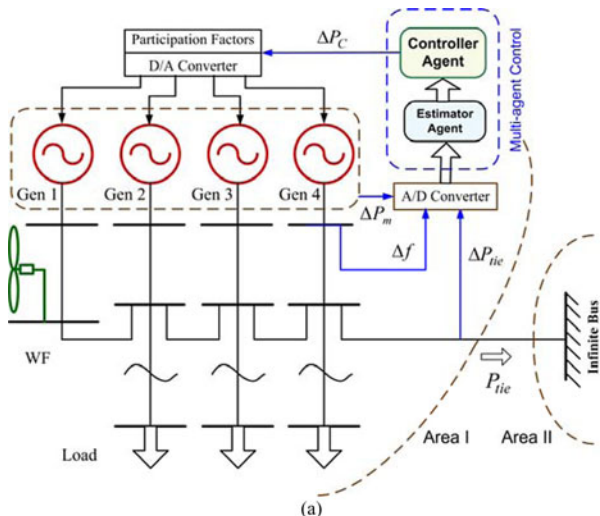

Fig. 7. Performed laboratory experiment. (a) Block diagram representation. (b) Physical configuration.

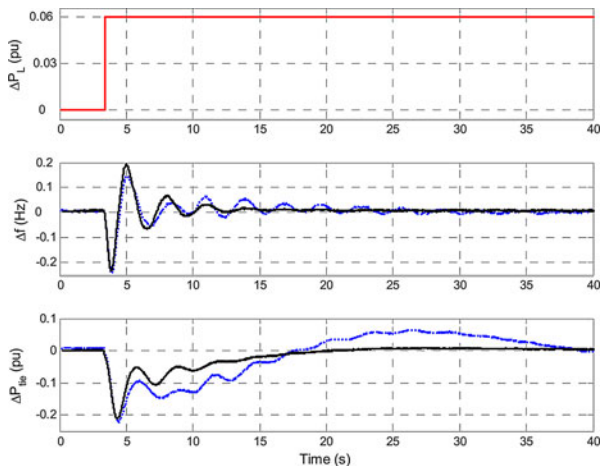

Fig. 8. System response following a 0.06 p.u. step load change. Proposed multiagent BNs method (solid line) and MARL method (dashed line).

the frequency deviation and tie-line power change are properly maintained within a narrow band.

As a severe test scenario, the power system is examined in the presence of a sequence of step load changes. The load change pattern and the system response are shown in Fig. 9. The obtained results show that the designed controllers can ensure good performance despite load disturbances. It is shown that the

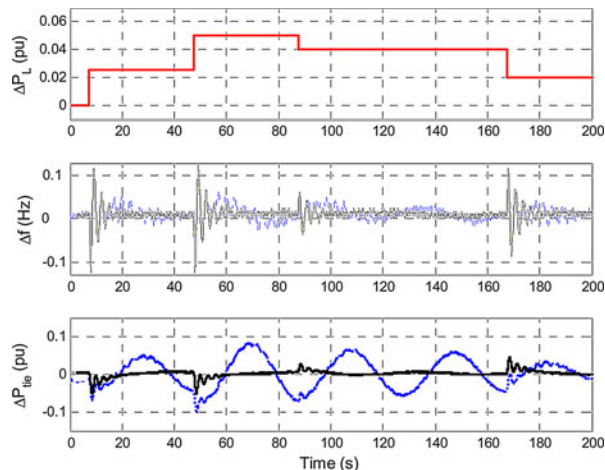

Fig. 9. System response following a sequence of step load changes. Proposed multiagent BNs method (solid line) and MARL method (dashed line).

proposed intelligent AGC system acts to maintain area frequency and total exchange power closed to the scheduled values by sending corrective smooth signal to the generators in proportion to their participation in the AGC task. Better transient and regulation performance for BN method in experimental study is due to the capability of BN-based AGC scheme against uncertain and incomplete model information. Since the infinite bus cannot behave similar to an actual control area, the present test system can be considered to be a suitable example to evaluate AGC control schemes.

Under conditions of uncertainty, the BN-based control agent (using a more flexible software and protocol structure [19]), which provides a more robust learning method with a less dependence to environment conditions, is capable to represent a better performance than the MARL method. For the sake of comparison, the closed-loop system is examined in the presence of conventional PI-based AGC system (which is well tuned by the expert operators of the APSS) for the aforementioned two disturbance scenarios. The real-time simulation results are shown in Fig. 10. The experimental results illustrate that the system performance using the proposed BN-based multiagent controller is quite better than the MARL technique and conventional-based AGC schemes.

VII. DISCUSSION

The AGC in multiarea power systems is known as one of the important power system control problems concerning the integration of renewable power energy sources such as wind power turbines. For the AGC systems of tomorrow, the structural flexibility and having a degree of intelligence are highly important. The core of such intelligent AGC system in the form of multiagent system (MAS) should be based on flexible intelligent algorithms, advanced information technology, and fast communication devices. In such systems, agents require real-time responses and must eliminate the possibility of massive communication among agents.

Dealing with complex dynamic systems, such as large-scale power systems, that can be described with the terms uncertainty,

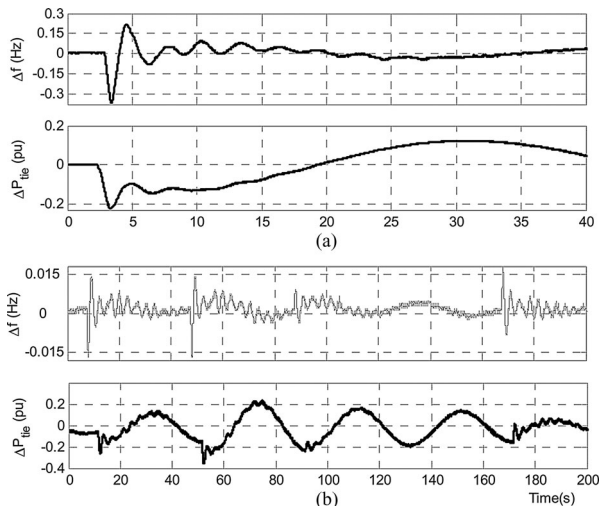

Fig. 10. System response with conventional controller following (a) 0.06 p.u. step load change. (b) Sequence of step load changes.

nonlinearity, information structure constraints, and dimensionality, it is very difficult to satisfy all requirements of an intelligent control system, such as adaptation and learning, autonomy and intelligence, as well as structures and hierarchies by using fuzzy controllers, neural networks, neurofuzzy, and evolutionary optimization methods like genetic algorithm as single applications. It is difficult to incorporate all these methods in one common framework that combines the advantages of the single method. However, the application of MASs could be considered to be an approach to design an intelligent control system to autonomously achieve a high level of control objectives.

Therefore, in response to the existing challenge of integrating computation, communication, and control into appropriate levels of AGC system, this paper introduces an intelligent BN-based multiagent control scheme to satisfy AGC objectives in the presence of wind power units. The main intelligent core of the controller agent is utilized based on the BN which is known as a powerful tool for knowledge representation and inference in control systems with uncertainties and undefined dynamics. The BN can be effectively used to incorporate expert knowledge and historical data for revising the prior belief in the light of new evidence in many fields. The main feature of the BN is in the possibility of including local conditional dependences into the model, by directly specifying the causes that influence a given effect.

To cover a minimum number of required processing/activities to the AGC system, the operating center for each area includes only two agents: The estimator and controller agents. In the first agent, special care was taken regarding the provision of appropriate signals following a filtering and signal conditioning process on the measured signals and received data from the input channels, and, finally, estimation of amount of load change. The controller agent uses the received data from the estimator agent to provide appropriate control action signals for the participating generating units.

For the sake of learning process for the neural-network-based AGC system [20], one can provide a long-term simulation for

the considered power system in the presence of various test scenarios. Since the BN is inference-based logic and new cases can be inferred from the training table data, it is not necessary to apply huge amount of data for the learning process. The possibility of representing the interrelationships among the dataset attributes is also a major advantage of the BNs over many other types of learning and predictive models, such as reinforcement method. Furthermore, the model independence and flexibility in specifying the control objectives identify the proposed approach as an attractive solution for AGC design in a real-world power system. The BN also provides a robust probabilistic method of reasoning under uncertainty, and moreover, using multiagent structure in the proposed control framework realizes parallel computation and a high degree of scalability.

The main advantages of the proposed BN-based MAS scheme for the AGC application can be summarized as follows: 1) Simplicity and intuitive model building that is closely based on the physical power system topology; 2) easy incorporation of uncertainty and dependence in the frequency response model; 3) capability to monitor the probability of any variable in the whole system; 4) propagation of probabilistic information that allows a large range of what-if analysis which is useful in wide area monitoring and control; and 5) independent to the power system parameter values such as frequency bias factor.

VIII. CONCLUSION

The MAS concepts and its great potential value to the AGC systems have been discussed, and it is shown that the BNs can provide a useful adaptive control technique that can be easily applicable in the AGC design in multiarea power system. In this paper, BN-based multiagent control methodology is proposed for AGC synthesis concerning the integration of wind power units in a large-scale power system.

The proposed method was applied to the New England power test system. An experimental examination is also performed in APSS laboratory, Kyushu Electric Power Company. The results show that in comparison of designed agent-based reinforcement learning control and conventional AGC design, the new intelligent AGC scheme presents a desirable performance.

In addition to the regulating area frequency, the AGC system should control the net interchange power with neighboring areas at scheduled values. Therefore, a desirable AGC performance is achieved by effective adjusting of generation to minimize frequency deviation and regulate tie-line power flows. The AGC system realizes generation changes by sending signals to the under control generating units. Since the BNs are based on inference, it is not necessary to use a large amount of simulation data for numerous test scenarios during the learning process. Furthermore, the model independence, scalability, and flexibility in specifying the control objectives are important features of the new intelligent AGC approach.

As a future work, the authors are working on the AGC design for a modern power system in an open market environment using accuracy-based learning classifier system with continuous-valued inputs (known as XCSR) method.

APPENDIX

TABLE IV
SIMPLE PRESENTATION OF PROBABILITIES ACCORDING TO THE GRAPHICAL MODEL

ΔP_{tie} (pu)		ΔP_L (pu)		Δf (Hz)				ACE (pu)				ΔP_C (pu)		
ΔP_{tie}	$p(\Delta P_{tie})$	ΔP_L	$p(\Delta P_L)$	ΔP_{tie}	ΔP_L	Δf	$p(\Delta f \Delta P_L, \Delta P_{tie})$	ΔP_{tie}	Δf	ACE	$p(ACE \Delta P_{tie}, \Delta f)$	ACE	ΔP_C	$p(\Delta P_C ACE)$
-0.03	0.14	0.01	0.75	-0.03	0.01	0.002	0.75	-0.03	0.002	0.01	0.06	0.01	-0.04	0.7
-0.1	0.28	-0.2	0.02	-0.1	-0.2	-0.04	0.02	-0.1	-0.04	0.031	0.81	0.031	0.1	0.01
...

ACKNOWLEDGMENT

The authors would like to thank Y. Sato, K. Fujii, K. Tanaka, and M. Kanazawa for their help in successful doing of laboratory tests.

REFERENCES

- [1] L. Y. Pao and K. E. Johnson, "A tutorial on the dynamics and control of wind turbines and wind farms," in *Proc. Amer. Control Conf.*, St. Louis, MO, 2009, pp. 2076–2089.
- [2] P. S. Dokopoulos, A. C. Saramourtsis, and A. G. Bakirtzis, "Prediction and evaluation of the performance of wind-diesel energy systems," *IEEE Trans. Energy Convers.*, vol. 11, no. 2, pp. 385–393, Jun. 1996.
- [3] R. B. Chedid, S. H. Karaki, and C. El-Chamali, "Adaptive fuzzy control for wind diesel weak power systems," *IEEE Trans. Energy Convers.*, vol. 15, no. 1, pp. 71–78, Mar. 2000.
- [4] G. Lalor, A. Mullane, and M. O'Malley, "Frequency control and wind turbine technologies," *IEEE Trans. Power Syst.*, vol. 20, no. 4, pp. 1905–1913, Nov. 2005.
- [5] J. Morren, S. W. H. de Haan, W. L. Kling, and J. A. Ferreira, "Wind turbines emulating inertia and supporting primary frequency control," *IEEE Trans. Power Syst.*, vol. 21, no. 1, pp. 433–434, Feb. 2006.
- [6] H. Banakar, C. Luo, and B. T. Ooi, "Impacts of wind power minute-to-minute variations on power system operation," *IEEE Trans. Power Syst.*, vol. 23, no. 1, pp. 150–160, Feb. 2008.
- [7] Power Systems Engineering Research Center. (2009). Impact of increased DFIG wind penetration on power systems and markets. Final project report. [Online]. Available: <http://www.pserc.org/docsa>
- [8] H. Bevrani, F. Daneshfar, and P. R. Daneshmand, "Intelligent power system frequency regulation concerning the integration of wind power units," in *Wind Power Systems: Applications of Computational Intelligence*, L. F. Wang, C. Singh, and A. Kusiak, Eds. Heidelberg, Germany: Springer-Verlag, Jul. 2010, pp. 407–437.
- [9] T. Hiyama, H. Esaki, K. Mori, and T. Funabashi, "Experimental studies on multi-agent based AGC for isolated power system with dispersed power sources," *Eng. Intell. Syst.*, vol. 13, no. 2, pp. 135–140, 2005.
- [10] H. Bevrani, *Robust Power System Frequency Control*, 1st ed. New York: Springer-Verlag, 2009.
- [11] J. Pearl, *Probabilistic Reasoning in Intelligent Systems: Networks of Plausible Inference*. San Francisco, CA: Morgan Kaufmann, 1988.
- [12] K. Murphy, "An introduction to graphical models," Intel Research, Santa Clara, CA, Tech. Rep., 2001. Available: http://www.cs.ubc.ca/~murphyk/Papers/intro_gm.pdf.
- [13] F. Daneshfar and H. Bevrani, "Load-frequency control: A GA-based multi-agent reinforcement learning," *IET Generat. Transmiss. Distrib.*, vol. 4, no. 1, pp. 13–26, Jan. 2010.
- [14] P. Kundur, *Power System Stability and Control*. Englewood Cliffs, NJ: McGraw-Hill, 1994.
- [15] K. Murphy, "The Bayes net toolbox for Matlab," *Comput. Sci. Statist.*, vol. 33, pp. 1024–1034, 2001.
- [16] T. Sueyoshi and G. Tadiparthi, "Wholesale power price dynamics under transmission line limits: A use of an agent-based intelligent simulator," *IEEE Trans. Syst., Man, Cybern. C, Appl. Rev.*, vol. 38, no. 2, pp. 229–241, Mar. 2008.
- [17] H. Bevrani and T. Hiyama, "On load-frequency regulation with time delays: design and real-time implementation," *IEEE Trans. Energy Convers.*, vol. 24, no. 1, pp. 292–300, Mar. 2009.
- [18] H. Bevrani, A. Ghosh, and G. Ledwich, "Renewable energy sources and frequency regulation: Survey and new perspectives," *IET Renewable Power Generat.*, vol. 4, no. 5, pp. 438–457, 2010.

- [19] M. Khalgui and H. M. Hanisch, "Reconfiguration protocol for multi-agent control software architectures," *IEEE Trans. Syst., Man, Cybern. C, Appl. Rev.*, vol. 41, no. 1, pp. 70–80, Jan. 2011.
- [20] H. Bevrani, T. Hiyama, Y. Mitani, K. Tsuji, and M. Teshnehlab, "Load-frequency regulation under a bilateral LFC scheme using flexible neural networks," *Eng. Intell. Syst.*, vol. 14, no. 2, pp. 109–117, 2006.



Hassan Bevrani (S'90–M'04–SM'08) received the Ph.D. degree in electrical engineering from Osaka University, Osaka, Japan, in 2004.

From 2004 to 2006, he was a Postdoctoral Fellow with Kumamoto University, Kumamoto, Japan. From 2007 to 2008, he was a Senior Research Fellow with the Queensland University of Technology, Brisbane, Australia. From 2009 to 2010, he was a Professor with Kumamoto University. Since 2000, he has been an Academic Member with the University of Kurdistan, Sanandaj, Iran. His current research interests include

smart grids, intelligent and robust control applications in power system and power electronic industry.



Fatemeh Daneshfar received the B.Sc. degree in electrical and computer engineering from the University of Tehran, Tehran, Iran, and the M.Sc. degree in artificial intelligence from the University of Kurdistan (UOK), Sanandaj, Iran, in 2003 and 2009, respectively.

She was the Chairperson of the UOK-IEEE student branch from fall 2008 to fall 2009. She is currently a Lecturer with the Department of Electrical and Computer Engineering, UOK. Her research interests include multiagent systems and intelligent

solutions for control systems.



Takashi Hiyama (M'86–SM'93) was born in Japan. He received the B.E., M.S., and Ph.D. degrees from Kyoto University, Kyoto, Japan, in 1969, 1971, and 1980, respectively, all in electrical engineering.

Since 1989, he has been a Professor with the Department of Electrical and Computer Engineering, Kumamoto University, Kumamoto, Japan. His current research interests include the application of intelligent systems to power system operation, management, and control.

Dr. Hiyama is a member of the Institute of Electrical Engineers of Japan, the Society of Instrument and Control Engineers of Japan, and the Japan Solar Energy Society.