

**University of Kurdistan**

Dept. of Electrical Engineering  
Smart/Micro Grids Research Center  
[smgrc.uok.ac.ir](http://smgrc.uok.ac.ir)

## **Intelligent Demand Response Contribution in Frequency Control of Multi-area Power Systems**

P. Babahajiani, Q. Shafiee, and H. Bevrani

Published (to be published) in: *IEEE Transactions on Smart Grid*

(Expected) publication date: **2018**

### **Citation format for published version:**

P. Babahajiani, Q. Shafiee, and H. Bevrani "Intelligent Demand Response Contribution in Frequency Control of Multi-area Power Systems," *IEEE Transactions on Smart Grid*, vol.9, no. 2, pp. 1282-1291, March 2018.

### **Copyright policies:**

- Download and print one copy of this material for the purpose of private study or research is permitted.
- Permission to further distributing the material for advertising or promotional purposes or use it for any profit-making activity or commercial gain, must be obtained from the main publisher.
- If you believe that this document breaches copyright please contact us at [smgrc@uok.ac.ir](mailto:smgrc@uok.ac.ir) providing details, and we will remove access to the work immediately and investigate your claim.

# Intelligent Demand Response Contribution in Frequency Control of Multi-area Power Systems

Pouya Babahajiani, Qobad Shafiee, *Member, IEEE*, and Hassan Bevrani, *Senior Member, IEEE*

**Abstract**— Frequency control is one of the most important issues in a power system due to increasing size, changing structure and the complexity of interconnected power systems. Increasing economic constraints for power system quality and reliability and high operational costs of generation side controllers have inclined researchers to consider demand response as an alternative for preserving system frequency during off-normal conditions. However, the main obstacle is calculating the accurate amount of load related to the value of disturbances to be manipulated, specifically in a multi-area power system. Dealing with this challenge, this paper makes an attempt to find a solution via monitoring the deviations of tie-line flows. The proposed solution calculates the magnitude of disturbances and simultaneously determines the area where disturbances occurred, to apply demand response exactly to the involved area. To address communication limitations, the impact of demand response delay on the frequency stability is investigated. Furthermore, this paper introduces a fuzzy-PI-based supervisory controller as a coordinator between the demand response and secondary frequency control avoiding large frequency overshoots/undershoots caused by the communication delays. To evaluate the proposed control scheme, simulation studies are carried out on the 10-machine New England test power system.

**Index Terms**—Frequency control, fuzzy-PI coordinator, multi-area power system, regional demand response, time delay.

## NOMENCLATURE

$\Delta P_{ie,i}$	Total tie-line power change between area $i$ and other areas.
$\Delta f$	Frequency deviation in Hz.
$T_{ij}$	Tie-line synchronizing torque coefficient.
$D$	Load damping coefficient.
$H$	Equivalent inertia constant.
$\Delta P_{Li}$	Load change in area $i$ .
$\Delta P_m$	Mechanical power change.
$\Delta P_{mni}$	Mechanical power change of $n^{\text{th}}$ governor-turbine of area $i$ .
$R$	Speed-droop characteristic.

$\Delta P_c$	Secondary control action.
$\Delta P_g$	Governor valve position change.
$T_g$	Governor time constant.
$T_t$	Turbine time constant.
$RDR_i$	Calculated load for demand response task.
$\gamma$	Participation factor of demand response.
$ACE$	Area control error.
$\beta$	Frequency bias.
$\tau$	Demand response time delay.
$P_{wind}$	Total wind power generation.
$G_i$	Generator number $i$ .
$K_P$	Proportional gain of PI controller.
$K_i$	Integral gain of PI controller.

## I. INTRODUCTION

FOLLOWING a severe system stress, say a large generation loss or noticeable step load disturbances, the power imbalance between generation and demand may lead system to under frequency situations. In such cases, the system needs to be controlled in a short time (within tens of seconds), yet the combined response of traditional methodologies such as governors and automatic generation controllers (primary and secondary controllers) may not be sufficient, reliable and secure [1]. In addition, due to the slow dynamic of generators mechanical parts, frequency cannot be restored in the first few seconds. Although energy storage devices (e.g. batteries, flywheels and ultra capacitors) have been introduced to improve the performance and stability in the power systems [2], due to the low efficiency, high operational cost of the devices [3], and also high operational cost of generation side controllers [4], demand response has been taken into account as a solution to enhance power system reliability and security [5]-[7].

Demand response is the ability to control and manipulate demand side loads to turn them off/on or change their consumption based on situation and in response to power quality, system security, voltage and frequency, technical and economic constraints, applied by grid operators. This concept first was introduced by Shweppe et al. [8], in 1980, responding to the need for seeking a faster and more reliable method than the traditional ones, to maintain balance between generation side and demand side.

Typically, power system frequency control has been divided into two main categories: 1) normal controls applied in the normal situations to stay in or return into normal condition, 2)

This work was supported by the Smart/Micro Grid Research Center at the University of Kurdistan, Sanandaj, Kurdistan, Iran.

P. Babahajiani is with the Department of Research and Development, Kurdistan Barez Tire Corporation, Sanandaj, Kurdistan, Iran, and also with the Department of Electrical and Computer Engineering, University of Kurdistan, Sanandaj, Kurdistan, Iran (e-mail: p.babahajyani@ec.iut.ac.ir).

Q. Shafiee, and H. Bevrani are with the Department of Electrical and Computer Engineering, University of Kurdistan, Sanandaj, Kurdistan, Iran (e-mail: q.shafiee@uok.ac.ir; bevrani@uok.ac.ir).

emergency controls, for instance, under frequency load shedding (UFLS), which are applied in emergency conditions, as the last option to prevent the risk of cascade faults and additional generation events [1]. Recent studies have shown that demand response could play more important and effective role, and as the first option not the last, in order to control the system frequency. Furthermore, demand response has the potential to decrease the generation side contribution in frequency control that consequently reduces CO<sub>2</sub> emission [9], energy consumption and the required amount of reserves and hence the system operational costs [10]. Appliances which are capable of performing their duty, in spite of compulsory blackouts during the day without causing any harm to the customers, are most suitable for demand response. Electric water heaters, refrigerators, freezers, air conditioners, ovens, heating systems and plug-in electric vehicles are examples of these appliances [11], [12].

Demand response because of its fast dynamic could be an appealing alternative to damp the system frequency deviations. A technical review on some practical challenges of contributing demand response in power systems frequency control, such as synchronization of electrical loads and advantages/drawbacks of centralized and decentralized structures have been provided in [13]. In [4], a distributed frequency control algorithm through randomizing frequency response of smart appliances is proposed. In this approach, it is assumed that generation side controllers are deactivated and demand response is completely responsive.

The contribution of demand response in frequency control of power systems and isolated microgrids [14], [15], has been studied in the literature using frequency-sensitive load controllers with different frequency-time characteristics [11], [16], saturable reactors [17], and selective load control scheme, with the contribution of electric vehicles charging interfaces [18]. Moreover, coordination of demand response and local frequency control, considering the impact of communication delay on frequency stability is investigated in [9], [19].

The participation of domestic refrigerators in primary frequency control via a stochastic control algorithm, to adjust the duty cycle of the refrigerators has been evaluated in [21]. H. Hao et. al in [22] tried to evaluate the effect of controllable loads on system frequency response, and more specifically on the load damping coefficient. Authors in [23] proposed a multi-agent demand control to provide primary and secondary frequency reserves to imitate the frequency response applied by conventional generators. Considering demand response as a kind of spinning reserve, some works have been done in [20]. In [24], the cooperation of demand response and spinning reserve in frequency restoration during system contingencies is proposed. In this work a low-order frequency response model (in a single area system) has been used to estimate the disturbances. In [25], the exploitation of demand response as frequency controlled reserve, using simple frequency threshold based controllers is suggested. In [26], the impact of utilizing appliances with programmable thermostats, relay-controlled loads and industrial pump loads, on frequency

regulation in an island, with high penetration of wind energy has been tested. Authors in [27] addressed a decentralized optimal load control methodology via estimating the amount of generation and demand imbalance, using an unbiased and minimum variance estimation method.

Despite high contribution of demand response in frequency regulation, several operating concerns still exist. On the one hand, over-shedding can cause unnecessarily shedding of load and consequently lead system to excessive over-frequency. On the other hand, light utilization of demand response during system faults may degrade its positive impacts, for instance, on primary frequency control, CO<sub>2</sub> emission, energy consumption and system operational costs. Hence, knowing the accurate magnitude of disturbances and the location of shed load specifically in a multi-area power system or a cluster of microgrids is vital [28]. The given method in [30] uses the variation of reactive power in buses to locate the change in the real power consumption of controllable loads. However, reactive power variation may not be a suitable indicator for the location of disturbances, especially when most of the appliances are resistive loads.

The present paper proposes a method to determine the magnitude and location of load disturbances in multi-area power systems via monitoring tie-line power flows, implementing demand response regionally, (i.e., regional demand response). The main contributions of this work can be outlined as follows:

- The present paper introduces monitoring tie-line power variations to extract the magnitude and location of disturbances and provides some mathematical calculations to support the proposed approach. Opposed to the similar work in [29] which uses wavelet transform analysis, the proposed approach here is more simple and accurate, and requires no massive and complex computational calculations.
- Unlike the work in [30] which accounts only for inductive loads, the proposed approach is applicable for almost all types of domestic loads considering this point that, most of residential and commercial devices (e.g., electric water heaters, cooking appliances, lighting loads, electric devices, thermostat-controlled loads and small induction motors) are usually resistive loads [18], [31].
- Since most of demand response programs are voluntary and contract-based, contribution and participation of demand response in frequency control might vary with time. Consequently, some technical issues may happen in light of variable interference of demand response. Furthermore, time delay, e.g., communication delay and measurement delay might degrade the system performance and causes instability. Therefore, existence of a coordination between generation and demand sides seems important. To the best of our knowledge, there is no distinctive work in the literature to provide such a coordination. This paper offers an intelligent coordination between secondary control (generation side) and demand response (demand side) through a supervisory fuzzy-PI-based coordinator.
- The proposed method is verified at the presence of high

penetration of wind power generation and in a large realistic test system, against sequence of load disturbances and in the presence of communication latency.

The rest of this paper is organized as follows: Section II presents regional demand response (RDR) and the methodology to calculate the magnitude of disturbances based on the second derivative of tie-line power changes. A discussion on technical aspects is also provided in this section. The fuzzy-PI based scheme is addressed in Section III. Section IV gives the test system details and parameters. In Section V simulation studies are provided to demonstrate the effectiveness of the proposed methodology. Finally, Section VI concludes the paper.

## II. REGIONAL DEMAND RESPONSE

### A. Estimation of System Load Change

Power systems have a highly nonlinear and time varying nature. However, for the purpose of frequency control synthesis and analysis in the presence of load disturbances, a simple linearized low order model is used. In comparison with other system dynamics (voltage and rotor angle), the dynamics that affecting frequency response are relatively slow, in the range of seconds to minutes [1].

In a power system with  $N$ -control areas, the total tie-line power change between area  $i$  and other areas is [1]:

$$\begin{aligned} \Delta P_{tie,i} &= \sum_{j=1, j \neq i}^N \Delta P_{tie,ij} \\ &= \frac{2\pi}{s} \left[ \sum_{j=1, j \neq i}^N T_{ij} \Delta f_i - \sum_{j=1, j \neq i}^N T_{ij} \Delta f_j \right] \end{aligned} \quad (1)$$

Suppose that in a two area power system, a disturbance is applied just to area one:

$$\Delta P_{tie,1} = \frac{2\pi}{s} (T_{12} \Delta f_1 - T_{12} \Delta f_2) \quad (2)$$

According to Fig. 1, where elements of a control area, i.e., control area  $i$ , are represented with a simple first order model, one can write:

$$\Delta f_2 = (-\Delta P_{tie,2} - \Delta P_{L2} + \sum_{i=1}^n \Delta P_{m2i}) \frac{1}{D_2 + 2H_2 s} \quad (3)$$

Therefore, with no speed governing at  $t = 0^+ s$ ,  $\sum \Delta P_m = 0$  [1]. In addition,  $\Delta P_{L2} = 0$ ; then (3) can be simplified as

$$\Delta f_2 = \frac{-\Delta P_{tie,2}}{D_2 + 2H_2 s} \quad (4)$$

where

$$\Delta P_{tie,2} = \frac{2\pi}{s} (T_{21} \Delta f_2 - T_{21} \Delta f_1) \quad (5)$$

At  $t = 0^+ s$ ,  $\Delta f_2$  in (2) could be ignored (please see Appendix I-A) and

$$\Delta P_{tie,1} = \frac{2\pi}{s} T_{12} \Delta f_1 \quad (6)$$

Hence, for a multi-area power system (1), at  $t = 0^+ s$  the term  $\sum_{j=1, j \neq i}^N T_{ij} \Delta f_j$  can be ignored.

Now, assume that load disturbances are applied to area  $i$ :

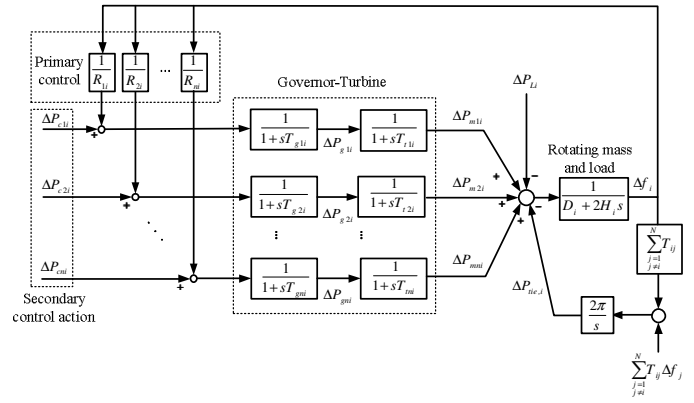

Fig. 1. Block diagram representation of control area  $i$ .

$$\Delta P_{tie,i} = \frac{2\pi}{s} \left( \sum_{j=1, j \neq i}^N T_{ij} \Delta f_i \right) = \frac{K}{s} \Delta f_i, \quad \text{at } t = 0^+ s \quad (7)$$

where

$$K = 2\pi \sum_{j=1, j \neq i}^N T_{ij} \quad (8)$$

According to Fig. 1

$$\Delta f_i = \frac{-1}{D_i + 2H_i s} (\Delta P_{tie,i} + \Delta P_{Li}) \quad (9)$$

Considering (7) and (9), one can write

$$\left( \frac{s}{K} + \frac{1}{D_i + 2H_i s} \right) \Delta P_{tie,i} = \frac{-\Delta P_{Li}}{D_i + 2H_i s} \quad (10)$$

For a step change in load by  $\Delta P_{Li}$ , Laplace transform of the load change is:

$$\Delta P_{Li}(s) = \frac{\Delta P_{Li}}{s} \quad (11)$$

Substituting (11) in (10) yields

$$\begin{aligned} \Delta P_{tie,i} &= \frac{-K \Delta P_{Li}}{s(2H_i s^2 + D_i s + K)} \\ &= -\Delta P_{Li} \frac{K/2H_i}{s(s^2 + D_i/2H_i + K/2H_i)} \end{aligned} \quad (12)$$

After some calculations, one can readily obtain that (please see Appendix I-B)

$$\Delta P_{Li} = -\frac{H_i}{\pi} \frac{d^2 \Delta P_{tie,i}(t)}{\sum_{j=1, j \neq i}^N T_{ij}} pu. \quad (13)$$

As can be seen, the step load is negatively proportional to the second derivative of the disturbed area tie-line power.

Now, similarly the tie-line power of the other areas at  $t = 0^+ s$  can be calculated. According to the analysis provided in Appendix I-A

$$\Delta P_{tie,j} = -\frac{2\pi}{s} T_{ij} \Delta f_i, \quad j \neq i \quad (14)$$

Considering (7) and (14),  $\Delta P_{tie,j}$  can be obtained as follows

$$\Delta P_{tie,j} = -\frac{2\pi T_{ij}}{K} \Delta P_{tie,i}, \quad j \neq i \quad (15)$$

Therefore, the signs of other areas tie-line powers are different from the tie-line power of area  $i$  as the disturbed area at  $t = 0^+ s$ . Thus, based on these results the disturbed area could

be easily distinguished.

### B. Contribution Mechanism

Considering above analytic approach, an algorithm is proposed for implementing the RDR in frequency control. At the first step of the algorithm the second derivative of tie-line flows of all areas are calculated. Since the second derivative may be sensitive to noise, a high pass filter is utilized. It should be noted that, this filter does not add such accountable delay to the algorithm.

Afterward, based on the sign of tie-line flows, the disturbed area, i.e., area  $i$ , is identified under the following conditions:

$$\text{If } \frac{d^2}{dt^2} \Delta P_{tie,j} > 0 \text{ and } \frac{d^2}{dt^2} \Delta P_{tie,i} < 0$$

or

$$\text{If } \frac{d^2}{dt^2} \Delta P_{tie,j} < 0 \text{ and } \frac{d^2}{dt^2} \Delta P_{tie,i} > 0$$

for  $j=1, \dots, n, j \neq i$

The value of load to be disconnected or reconnected in each area ( $RDR_j$ ) during the demand response process is obtained:

$$RDR_j = 0 \text{ for } j=1, \dots, n, j \neq i \quad (16)$$

and

$$RDR_i = \frac{-H_i \frac{d^2}{dt^2} \Delta P_{tie,i}(t)}{\pi \sum_{j=1, j \neq i}^n T_{ij}} \times \gamma \quad (17)$$

As mentioned, some demand response programs are contract-based and voluntary. Therefore, to apply the impact of this limitation, the participation factor  $0 < \gamma < 1$  in (17) is considered so that,  $\gamma$  determines how much load could contribute in demand response at the time of disturbance.  $\gamma=0$  means that all the required regulation would be provided by the generation side and the RDR has no participation, and  $\gamma=1$  means that the total available active loads for the RDR are involved in the system frequency control. The impact of the different values of  $\gamma$  is investigated in the simulation studies.

It should be noted that, once the tie-line flows is employed to calculate the value of the load disturbance, they would not be used for about 2 or 3 seconds, as disconnecting or reconnecting loads for demand response task causes changes in tie-line flows again which may be interpreted as disturbance itself.

In this algorithm the RDR is utilized under the circumstance of sudden load changes. Other types of disturbances, such as wind power fluctuations, are handled by the generation side. Thus, a deadband is used to meet this purpose.

Figure 2 shows how the RDR algorithm contributes in the system frequency control, where  $\tau_i$  is the RDR delay of area  $i$ . In this algorithm it is assumed that at any time, step load is applied only to one of the areas. This assumption is quite close to the reality.

### C. Discussion: Technical Aspects and Considerations

#### 1. Demand Response Potential

Apart from economic, technical and regulatory limitations

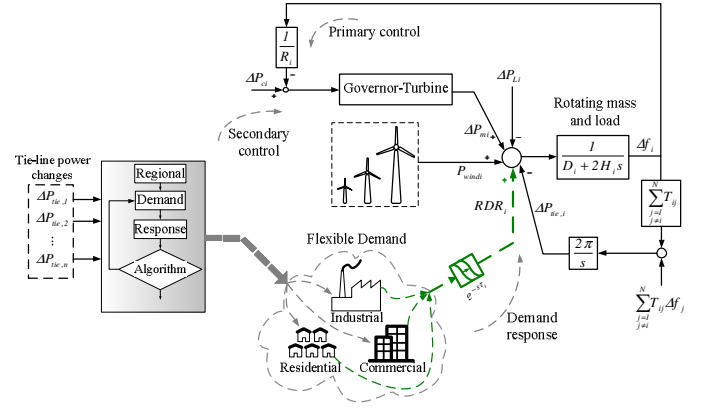

Fig. 2. System frequency response model with RDR auxiliary control.

and barriers such as measurement challenges, lack of real time information sharing, and advanced metering infrastructure [33], in several countries, the potential of demand response in providing ancillary services has been investigated. The Federal Energy Regulatory Commission (FERC) in the United States of America has reported that [34], a full participation of controllable loads could offer a 20% reduction of the peak demand by 2019. Residential thermostatically controlled loads (e.g., air conditioners, heat pumps, water heaters, and refrigerators) account for 20% of the total electricity consumption in the United States that could be taken into consideration for providing various ancillary services [34]. It has been reported that in some regions, electric heaters represent about 11% of the total electricity consumption [35]. For the sack of simulation, in this paper, in order to evaluate the proposed methodology, it is assumed that in each control area 30% of loads are controllable for demand response actions.

#### 2. Infrastructure

Technological and regulatory limitations like communication infrastructure and availability of demand response are two major limitations for grid operators. Grid operators need information that how much load is available at the time of disturbance. Knowing the state and power consumption of devices seems to be so important since it could be used to apply different ancillary services via demand response. There are some useful works in the literature on how to get information about the states of controllable loads and home appliances [36], [37]. For example, authors in [36] propose a hierarchical communication network to aggregate and send information about the loads to the transmission system operator in real-time, by means of smart meters installed on appliances. This method could provide information regarding the available frequency response from controllable loads every minute. The concept presented in our paper assumes such proposed method in [36] as a base.

#### 3. Demand Response in Contingent Events

Demand response can be divided into two basic categories, including price-based and incentive-based programs [33]. In price-based programs, users try to change their consumption based on different electricity prices at different times provided by system utility, which is out of the scope of this paper. In

incentive-based programs, clients change their consumption in response to incentive payments offered by electric utility. These programs are categorized into four classes: i) Direct load control, ii) Interruptible/curtailable load, iii) Demand bidding and buyback; and iv) Emergency demand response. The proposed methodology in this paper could be considered as direct load control (that is usually contract-based [38] and voluntary [39]) which could be useful in contingencies too. In this type of program, in case of a contingent event, system operator sends out an emergency message to all clients that participate in this program [40]. Utilizing demand response in contingent events might prevent power systems against overload as one of the most common abnormal operation conditions. Furthermore, it could decrease the possibility of activation of under frequency load shedding programs [35]. Much like under frequency load shedding, domestic appliances can provide load shedding at the time of disturbances and frequency excursions [41], [35]. Given that, these devices do not require continues power supply, shedding them would not cause any inconvenience to clients [35].

#### 4. Demand Response Modeling

Among residential appliances, thermostatically controlled loads are the best candidates to provide regulation reserve to the grid [42]. These types of loads are designed for switching between on and off states, in order to preserve the temperature within acceptable range [18]. Their thermal inertia (i.e., ability of maintaining thermal energy for noticeable time intervals) capable them to immediately and continuously respond to control signals of system operator [43] and being disconnected/reconnected during some minutes without causing any harm to consumers [18]. This characteristic makes the loads ideal for system frequency control. Therefore, in simulations, these devices are considered in their switching states. The mentioned consideration is fair because in daily operation, they are expected to operate in a specific state for large proportions of their operating time [44].

As mentioned, there are several constraints and limitations in applying demand response to real power systems. But, modeling demand response in simulation environments depends on what constraint is targeted. For instance, there are some works that have considered customer welfare [23], or economic constraints for modeling demand response [39], [45]. In the present paper, system frequency response is targeted. Regarding considering appliances in their switching mode for demand response tasks, there are lots of works reported in the literature [23]-[25], [35], [41], [43]-[49].

### III. FUZZY-PI-BASED SUPERVISORY COORDINATOR DESIGN

Time delay is an intrinsic feature of each physical system and demand response is not an exception. As mentioned, following a step change in load, demand response could have contribution in restoration of the system frequency. But, in case the demand response action is associated with time delay, during the time delay generators try to compensate the occurred power imbalance, for instance via increasing their generations. Afterward, when demand response interferes as a

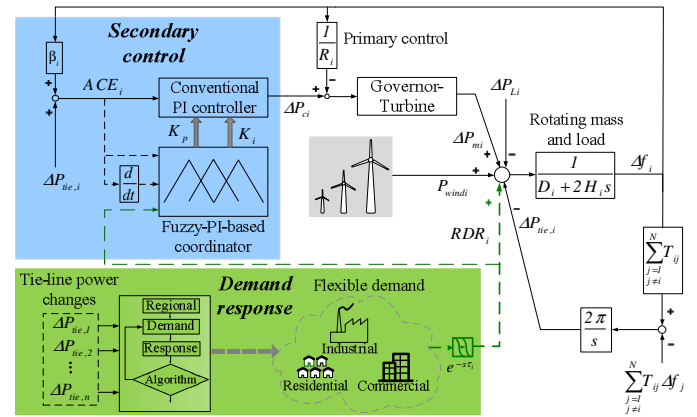

Fig. 3. System frequency response model with both RDR and supervisory fuzzy-PI-based coordinator.

supplementary control and compensates all or a part of the load/generation imbalance, the additional generation, produced during the time delay, may cause considerable frequency overshoots and impose instability to the system performance. Even if these excessive overshoots/undershoots do not jeopardize the system stability, after a while these extra useless generations would consume a considerable amount of fuel which also causes a considerable CO<sub>2</sub> emission.

In this paper, fuzzy logic is used to cope with this phenomenon, i.e., protecting the system against excessive overshoots/undershoots and consequently reducing CO<sub>2</sub> emission and to adjust the responsive generators according to the amount of regulation provided by the RDR. Therefore, fuzzy logic is used not only for handling control actions, but also for making coordination between generation side and demand side. Minimizing the frequency deviations due to fast changes in output power of wind turbines, and limiting the tie-line power interchanges in an acceptable range are the other goals of this effort.

Furthermore, the fuzzy logic is able to compensate the inability of the classic control theory for covering complex power systems with uncertainties and inaccuracies. Recent work of the authors in [2] demonstrates that fuzzy logic can be used as a suitable intelligent method for online tuning of PI controller parameters. In this case, fuzzy logic is used as a supervisor for fine tuning of conventional PI controllers. In the present work, the PI controller is remained, and the fuzzy logic is used for on-line tuning of its parameters. Therefore, this control configuration provides a smooth performance in startup and transient circumstances and it could be more acceptable for real-time LFC application.

In the present paper, in each control area, to cover both time delay side effects and system uncertainties, the RDR signal, the updated area control error (ACE) and its derivative are used as the inputs of the fuzzy block. ACE is defined as a linear combination of frequency and tie-line power changes [50]:

$$ACE = \beta \Delta f + \Delta P_{tie} \quad (18)$$

where  $\beta$  is the frequency bias. Figure 3 shows how supervisory fuzzy-PI-based coordinator contributes in frequency regulating.

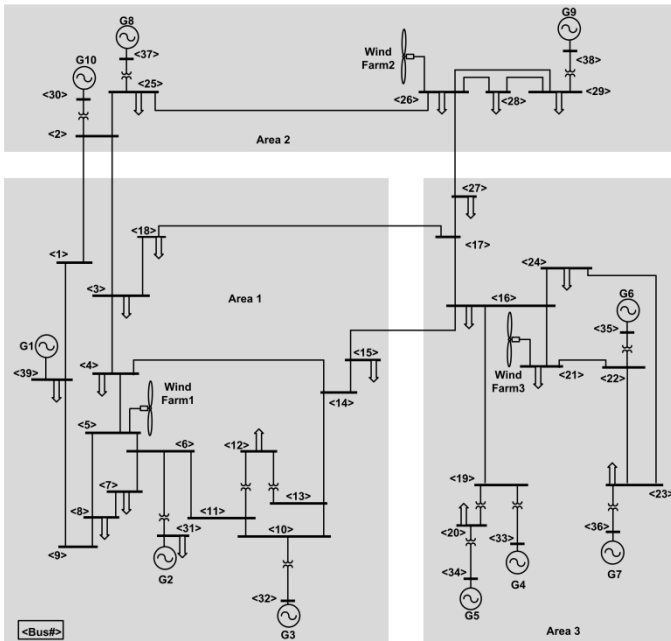

Fig. 4. Modified single-line diagram of 39-bus test system with three wind farms [32].

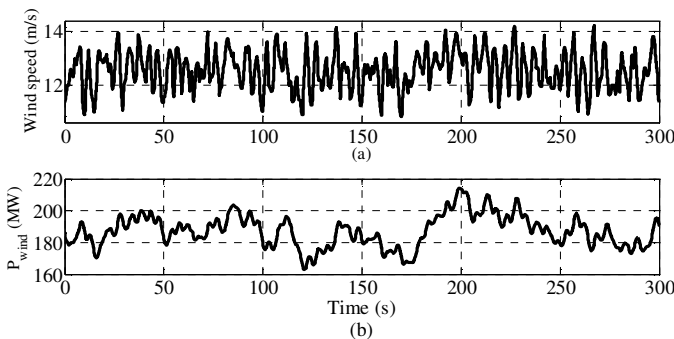

Fig. 5. Wind velocity and power: (a) wind velocity pattern and (b) total wind power generation.

In order to apply the fuzzy logic to each area, a set of fuzzy rules consisting of 60 rules is used to map input variables, i.e., ACE, its derivative and  $RDR_i$ , to output variables, i.e.,  $K_p$  and  $K_i$ . The membership functions corresponding to the input and output variables have been arranged based on triangular membership function which is most popular one. The antecedent parts of each rule are composed by using AND function (with interpretation of minimum). Here, Mamdani fuzzy inference system is also used. Membership functions are given in Appendix II.

#### IV. CASE STUDY

The New England test system is widely used as a standard system for testing of the power system analysis and control synthesis methodologies. This system has 10 generators, 19 loads, 34 transmission lines, and 12 transformers. Here, the test system is updated by adding three wind farms in buses 5, 26, and 21. A single-line diagram of the updated system is shown in Fig. 4.

The total system installed capacity is 404.85 MW of conventional generation and 185.9 MW of average wind power generation. There are 134.57 MW of conventional

power generation, 61 MW of average wind power generation, and 329.25 MW load in Area 1. In Area 2, there are 106.381 MW of conventional power generation, 54 MW of average wind power generation, and 74.051 MW load. In Area 3, there are 163.9 MW of conventional power generation, 72 MW of average wind power generation, and 182.01 MW load. All power plants in the power system are equipped with speed governor and power system stabilizer. In addition, the important inherent requirement and basic constraints such as governor dead band and generation rate constraint imposed by physical system dynamics are considered. The main simulation parameters for the generators are given in [51]. Other system parameters are given in Appendix III.

In the present work, similar to the real-world power systems, the conventional generation units are responsible to provide spinning reserve for the sake of load tracking and the load-frequency control (LFC) task. Here, it is assumed that only one generator in each area is responsible for the LFC task; G1 in Area 1, G9 in Area 2, and G4 in Area 3. All LFC loops use conventional proportional-integral (PI) controllers.

In order to evaluate the proposed method properly, high-penetration of wind power (about 30%) along with random variations of wind velocity have been considered. Figure 5 demonstrates the wind velocity pattern and total wind power generation.

#### V. SIMULATION RESULTS AND DISCUSSION

For the sake of simulation, four scenarios are examined and the effectiveness of the proposed method is investigated in MATLAB/SIMPOWER environment. It is assumed that in each control area 30% of loads are available for demand response actions, i.e., 98.77 MW in Area 1, 22.21 MW in Area 2 and 54.6 MW in Area 3.

At the first scenario, to demonstrate a comparison of conventional PI controller versus the RDR contribution clearly, random variations of wind velocity is eliminated and the system is examined in the face of a sequence of step load changes which is plotted in Fig. 6 (a), and a communication delay of 0.5 s. Furthermore, to show the efficiency of the calculations provided in Section II, the estimated load changes are also depicted in Fig. 6 (a). As can be seen, there is a significant resemblance between the estimated and actual load changes. Fig. 6 (b) and Fig. 6 (c) show that the proposed RDR can effectively reduce the amount of the frequency excursion and variations, and also demonstrate that the tie-line power changes are maintained within a narrow band.

At the next scenario, a severe step load disturbance of 115 MW applied to the area 1 at  $t=10$  s, at the presence of random variations of wind velocity in the system. First to evaluate the impact of communication delay of the RDR, the system is tested for different values of communication latency, without the contribution of supervisory coordinator. The results are depicted in Fig. 7. It can be seen that, the value of the frequency overshoot, following the interference of the RDR, is increased as the value of the communication delay get increased. Next, to cope with these overshoots and also system disturbances, the supervisory fuzzy-PI-based coordinator is

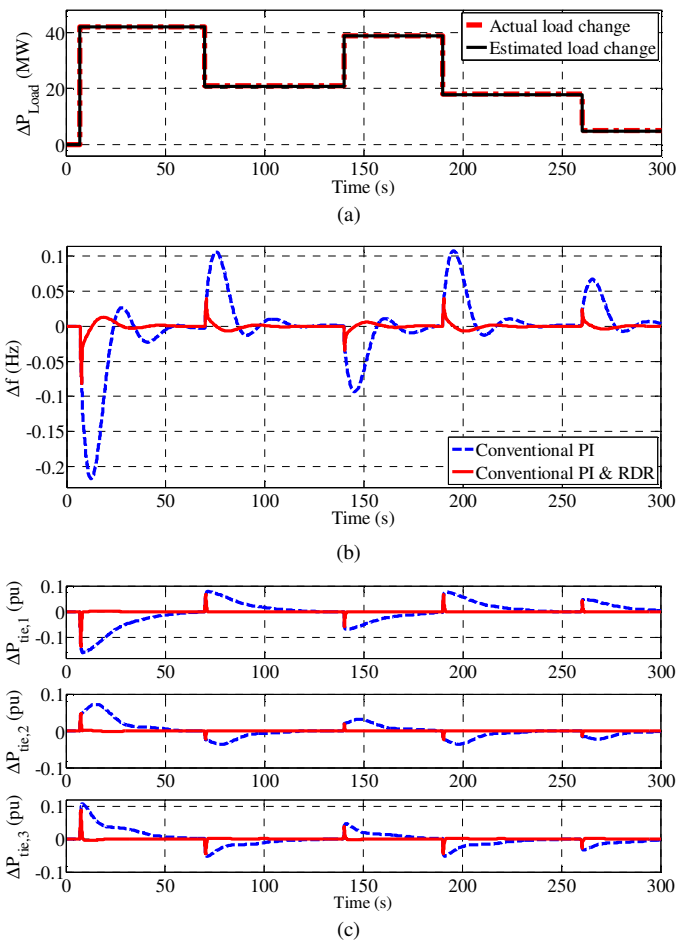

Fig. 6. System response following a sequence of step load changes in area 1: (a) load change pattern and estimated load change, (b) system frequency response; comparison of conventional PI controller versus the RDR contribution, (c) tie-line power interchanges; conventional PI (dashed), contribution of the RDR (solid).

added to the closed loop system and results are plotted in Fig. 8. The results illustrate that the Fuzzy-PI-based coordinator can effectively reduce the amount of the frequency overshoots and variations in the presence of communication delay and wind power fluctuations.

Finally, to show a comparison of conventional power plant frequency response versus the RDR and supervisory fuzzy-PI-based coordinator contribution, the test is repeated with the communication delay of 1 s, as shown in Fig. 9. For the rest of the simulations,  $\tau$  is assumed to be 1 s.

At the third scenario, random step loads are applied to all three areas according to Fig. 10(a). System frequency response and tie-line power changes, in the case of comparing the performance of conventional controllers versus participation of the RDR and supervisory fuzzy-PI-based coordinator are given in Fig. 10(b) and Fig. 10(c), respectively. The obtained results show that the designed method can ensure a good performance in a multi-area power system in the existence of random step load changes and wind power fluctuations.

As the last scenario, a comparison between the contribution of the responsive generator and the RDR in frequency regulation is made, by studying the impact of participation factor  $\gamma$ . To do so, the system is examined at the presence of

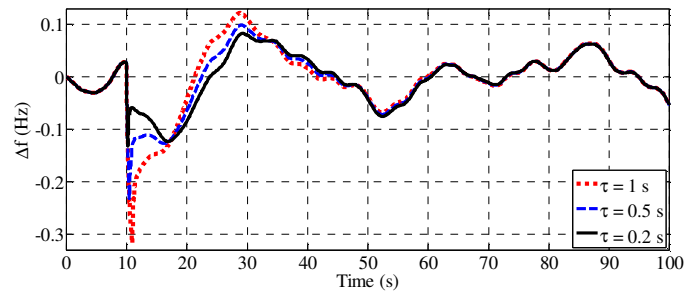

Fig. 7. Impact of communication delay ( $\tau$ ) on the performance of the proposed RDR scheme in response to a 115 MW step load at  $t=10$  s.

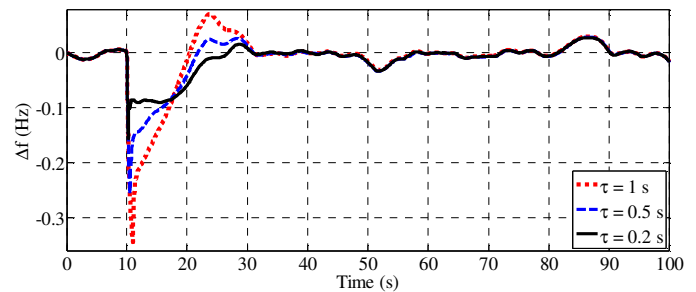

Fig. 8. Performance of the supervisory fuzzy-PI-based coordinator for different RDR delays.

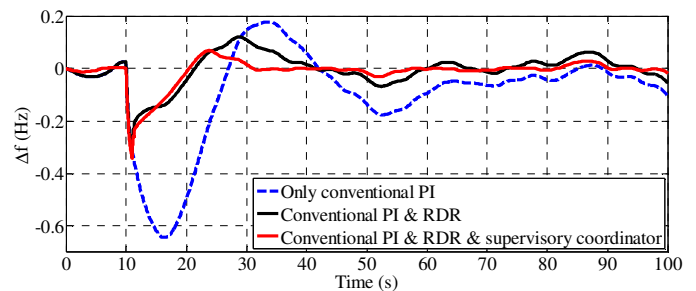

Fig. 9. Performance evaluation of the RDR and supervisory fuzzy-PI-based coordinator in comparison with the conventional PI controller for 1 s communication latency.

step load changes, applied to area 1, as depicted in Fig. 11(a) and the results are demonstrated in Fig. 11(b). According to the results, lower participation of the RDR results in more frequency variations and less system performance.

## VI. CONCLUSION

This paper proposes a regional demand response to cooperate in system frequency control of multi-area power systems. The striking feature of the proposed RDR scheme is the use of second derivative of tie-line power changes to extract the size and location of the experienced disturbances during contingent events, which is proved by mathematical calculations. A fuzzy-PI-based supervisory controller is introduced as a coordinator between the demand response and secondary frequency control to adjust the responsive generators according to the amount of regulation provided by the RDR. This coordinator will cover not only the system uncertainties but also time delay side effects of the RDR scheme.

The provided simulation studies on the 10-machine New England test power system illustrate the effectiveness of incorporating regional demand response and supervisory



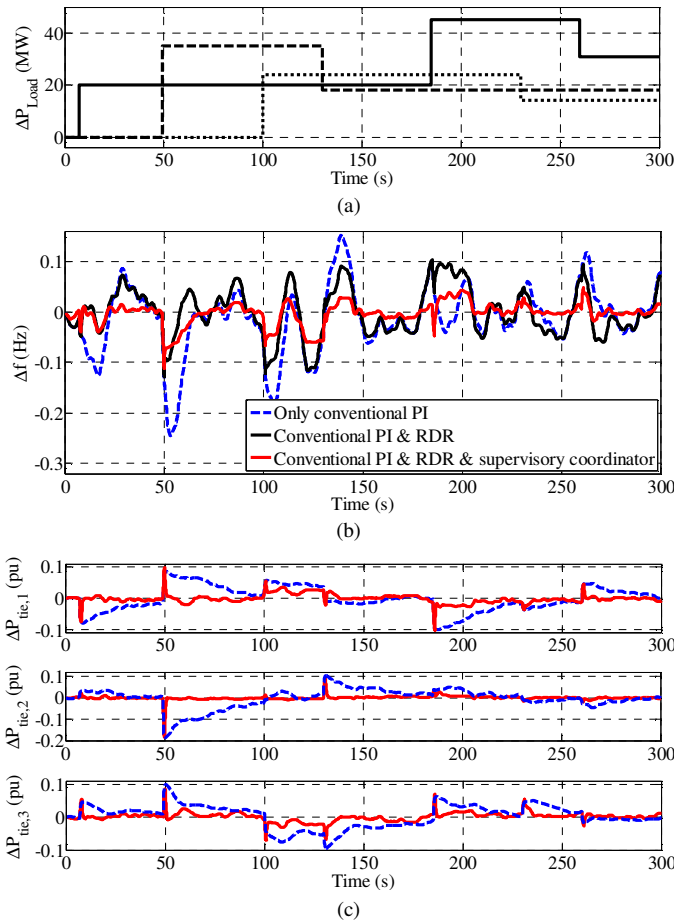

Fig. 10. System response following a sequence of step load changes in all areas: (a) load change pattern; Area 1 (solid), Area 2 (dashed), Area 3 (dotted), (b) system frequency response, (c) tie-line power interchanges; conventional PI (dashed), coordination of the RDR and supervisory fuzzy-PI-based coordinator (solid).

fuzzy-PI-based coordinator, at the presence of high wind power fluctuations, random load changes and communication delays, in multi-area power systems.

#### APPENDIX I

I-A) At  $t = 0^+ s$

$$\Delta f_2 = \frac{-\Delta P_{tie,2}}{D_2 + 2H_2 s} \quad (19)$$

Considering (5), one can write

$$(D_2 + 2H_2 s)\Delta f_2 = \frac{-2\pi}{s} T_{21}(\Delta f_2 - \Delta f_1) \quad (20)$$

$$\Delta f_1 = \left( \frac{2H_2 s^2 + D_2 s}{2\pi T_{21}} + 1 \right) \Delta f_2 \quad (21)$$

Taking the inverse Laplace transform, the time domain equation is obtained

$$\Delta f_1 = \Delta f_2 + \frac{D_2}{2\pi T_{21}} \frac{d}{dt} \Delta f_2 + \frac{2H_2}{2\pi T_{21}} \frac{d^2}{dt^2} \Delta f_2 \gg \Delta f_2 \quad (22)$$

Since  $\Delta f_1$  is proportional to the second derivative of  $\Delta f_2$  which is considerably greater than  $\Delta f_2$ , at  $t = 0^+ s$ ,  $\Delta f_2$  in (2) could be ignored.

I-B) Considering (12), one can write

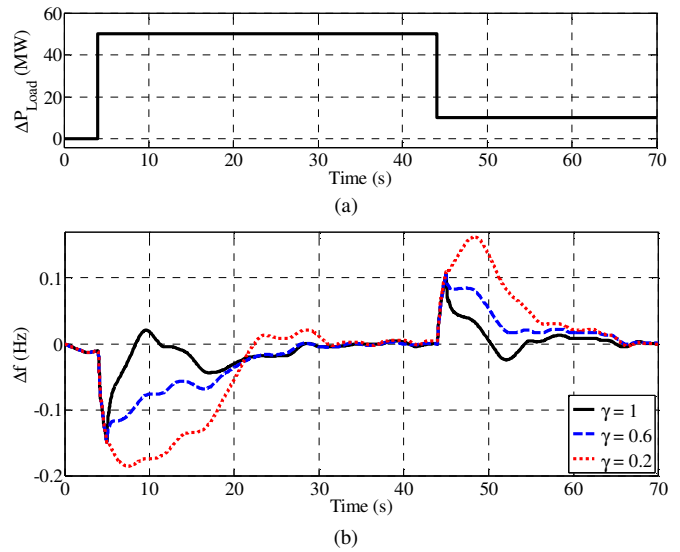

Fig. 11. Impact of changing the contribution of the RDR (participation factor  $\gamma$ ) in the required regulation: (a) load change pattern, (b) system frequency response.

$$\begin{aligned} s^2 \Delta P_{tie,i} &= -\Delta P_{Li} \frac{(K/2H_i)s}{s^2 + (D_i/2H_i)s + K/2H_i} \\ &= -\frac{\Delta P_{Li} K}{2H_i} \times \frac{s}{s^2 + 2\zeta\omega_n + \omega_n^2} \end{aligned} \quad (23)$$

where

$$\omega_n^2 = \frac{K}{2H_i}, \quad \zeta = \frac{D_i}{4H_i \sqrt{K/2H_i}} \quad (24)$$

Taking the inverse Laplace transform, the time domain equation is obtained

$$\frac{d^2 \Delta P_{tie,i}(t)}{dt^2} = \frac{\Delta P_{Li} \omega_n^2}{\sqrt{1-\zeta^2}} e^{-\zeta\omega_n t} \sin(\omega_n \sqrt{1-\zeta^2} t - \phi) \quad (25)$$

where

$$\phi = tg^{-1} \frac{\sqrt{1-\zeta^2}}{\zeta} \quad (26)$$

Hence, the second derivative of tie-line power at  $t = 0^+ s$  is proportional to the  $-\Delta P_{Li} K/2H_i$

$$\begin{aligned} \frac{d^2 \Delta P_{tie,i}}{dt^2} &= -\Delta P_{Li} \frac{\omega_n^2}{\sqrt{1-\zeta^2}} \sin(tg^{-1} \frac{\sqrt{1-\zeta^2}}{\zeta}) \\ &= -\Delta P_{Li} \frac{K}{2H_i} \end{aligned} \quad (27)$$

Therefore, (27) allows us to calculate the magnitude of the disturbance applied to area  $i$ :

$$\Delta P_{Li} = -\frac{H_i \frac{d^2}{dt^2} \Delta P_{tie,i}(t)}{\pi \sum_{j=1, j \neq i}^N T_{ij}} pu. \quad (28)$$

#### APPENDIX II

The membership functions corresponding to the input output variables are arranged as Negative Extremely Extremely Large (NEEL), Negative Very Extremely Large

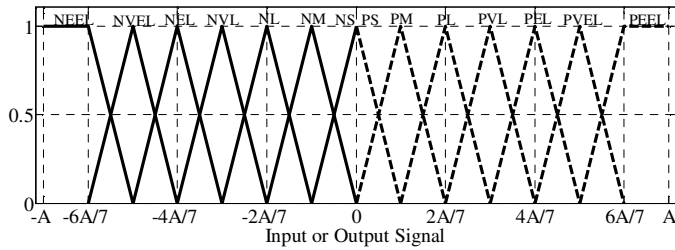

Fig. 12. Inputs and outputs membership functions pattern.

TABLE I  
STEAM TURBINE PARAMETERS

Very high pressure turbine power fraction ( $F_{VHP}$ )	0.28
High pressure turbine power fraction ( $F_{HP}$ )	0.36
Intermediate pressure turbine power fraction ( $F_{IP}$ )	0.36
Low pressure turbine power fraction ( $F_{LP}$ )	0
Steam chest time constant ( $T_{CH}$ ) [s]	0.5
Reheat time constant ( $T_{RH1}$ ) [s]	3.3
Second reheat time constant ( $T_{RH2}$ ) [s]	10
Crossover time constant ( $T_{CO}$ ) [s]	1

(NVEL), Negative Extremely Large (NEL), Negative Very Large (NVL), Negative Large (NL), Negative Medium (NM), Negative Small (NS), Positive Small (PS), Positive Medium (PM), Positive Large (PL), Positive Very Large (PVL), Positive Extremely Large (PEL), Positive Very Extremely Large (PVEL) and Positive Extremely Extremely Large (PEEL). They have been arranged based on triangular membership functions as depicted in Fig. 12, where  $A$  determines variation ranges of input and output signals as

$$ACE \in [-A, A], \text{ where } A = 0.7$$

$$d/dt ACE \in [-A, A], \text{ where } A = 1.5$$

$$RDR \in [0, A], \text{ where } A = 150e6$$

$$K_p \in [-A, 0], \text{ where } A = 10$$

$$K_i \in [-A, 0], \text{ where } A = 15$$

### APPENDIX III

In this paper complete tandem-compound steam prime mover, including a speed governing system and a four-stage steam turbine is utilized. The speed governing system consists of a proportional regulator, a speed relay, and a servomotor controlling the gate opening. For steam turbines, IEEE Tandem Compound, Double Reheat model is used which has four stages, each modeled by a first-order transfer function [52]. The main simulation parameters for the generators are given in Tables I.

### REFERENCES

[1] H. Bevrani, *Robust Power System Frequency Control*. 2nd Ed., New York: Springer, 2014.  
 [2] H. Bevrani, F. Habibi, P. Babahajyani, M. Watanabe, and Y. Mitani, "Intelligent Frequency Control in an AC Microgrid: Online PSO-Based Fuzzy Tuning Approach," *IEEE Trans. Smart Grid*, vol. 3, no. 4, pp. 1935-1944, Dec. 2012.

[3] K. Pandiaraj, P. Taylor, N. Jenkins, and C. Robb, "Distributed load control of autonomous renewable energy systems," *IEEE Trans. Energy Convers.*, vol. 16, no. 1, pp. 14-19, Jan. 2001.  
 [4] M. R. Vedydy Moghadam, R. T. B. Ma, and Z. Rui, "Distributed Frequency Control in Smart Grids via Randomized Demand Response," *IEEE Trans. Smart Grid*, vol. 5, no. 6, pp. 2798-2809, Nov. 2014.  
 [5] J. Medina, N. Muller, and I. Roytelman, "Demand Response and Distribution Grid Operations: Opportunities and Challenges," *IEEE Trans. Smart Grid*, vol. 1, no. 2, pp. 193-198, Sept. 2010.  
 [6] N. Navid-Azarbaijani and M. H. Banakar, "Realizing load reduction functions by aperiodic switching of load groups," *IEEE Trans. Power Syst.*, vol. 11, no. 2, pp. 721-727, May 1996.  
 [7] "Benefits of demand response in electricity markets and recommendations for achieving them: A report to U.S. Congress," U.S. Dept. Energy, 2006 [Online]. Available: <http://eetd.lbl.gov/ea/ems/reports/congress-1252d.pdf>.  
 [8] F. C. Schweppe, R. D. Tabors, J. L. Kirtley, H. R. Outhred, F. H. Pickel, and A. J. Cox, "Homeostatic Utility Control," *IEEE Trans. Power App. Syst.*, vol. PAS-99, no. 3, pp. 1151-1163, May 1980.  
 [9] K. Samarakoon, J. Ekanayake, and N. Jenkins, "Investigation of Domestic Load Control to Provide Primary Frequency Response Using Smart Meters," *IEEE Trans. Smart Grid*, vol. 3, no. 1, pp. 282-292, Mar. 2012.  
 [10] M. Aunedi, P. A. Kountouriotis, J. E. O. Calderon, D. Angeli, and G. Strbac, "Economic and Environmental Benefits of Dynamic Demand in Providing Frequency Regulation," *IEEE Trans. Smart Grid*, vol. 4, no. 4, pp. 2036-2048, Dec. 2013.  
 [11] G. Molina, x, A., F. Bouffard, and D. S. Kirschen, "Decentralized Demand-Side Contribution to Primary Frequency Control," *IEEE Trans. Power Syst.*, vol. 26, no.1, pp. 411-419, Feb. 2011.  
 [12] A. Brooks, E. Lu, D. Reicher, C. Spirakis, and B. Wehl, "Demand Dispatch," *IEEE Power Energy Mag.*, vol. 8, no. 3, pp. 20-29, May-June 2010.  
 [13] K. Dehghanpour and S. Afsharnia, "Electrical demand side contribution to frequency control in power systems: a review on technical aspects," *Renew. Sust. Energ. Rev.*, vol. 41, pp. 1267-1276, Jan. 2015.  
 [14] N. Rezaei and M. Kalantar, "Stochastic frequency-security constrained energy and reserve management of an inverter interfaced islanded microgrid considering demand response programs," *Int. J. Elect. Power Energy Syst.*, vol. 69, pp. 273-286, Jul. 2015.  
 [15] N. Rezaei and M. Kalantar, "Smart microgrid hierarchical frequency control ancillary service provision based on virtual inertia concept: An integrated demand response and droop controlled distributed generation framework," *Energy Conv. Manag.*, vol. 92, pp. 287-301, Mar. 2015.  
 [16] A. Molina-Garcia, I. Munoz-Benavente, A. D. Hansen, and E. Gomez-Lazaro, "Demand-Side Contribution to Primary Frequency Control With Wind Farm Auxiliary Control," *IEEE Trans. Power Syst.*, vol. 29, no. 5, pp. 2391-2399, Sept. 2014.  
 [17] J. Hao, L. Jin, S. Yonghua, G. Wenzhong, X. Yu, S. Bin, L. Xiaomin, and D. Jianxun, "Demand Side Frequency Control Scheme in an Isolated Wind Power System for Industrial Aluminum Smelting Production," *IEEE Trans. Power Syst.*, vol. 29, no. 2, pp. 844-853, Mar. 2014.  
 [18] C. Gouveia, J. Moreira, C. L. Moreira, and J. A. Pecos Lopes, "Coordinating Storage and Demand Response for Microgrid Emergency Operation," *IEEE Trans. Smart Grid*, vol. 4, no. 4, pp. 1898-1908, Dec. 2013.  
 [19] S. A. Pourmousavi and M. H. Nehrir, "Introducing Dynamic Demand Response in the LFC Model," *IEEE Trans. Power Syst.*, vol. 29, no. 4, pp. 1562-1572, Jul. 2014.  
 [20] J. A. Short, D. G. Infield, and L. L. Freris, "Stabilization of Grid Frequency Through Dynamic Demand Control," *IEEE Trans. Power Syst.*, vol. 22, no. 3, pp. 1284-1293, Aug. 2007.  
 [21] D. Angeli and P. A. Kountouriotis, "A Stochastic Approach to "Dynamic-Demand" Refrigerator Control," *IEEE Trans. Control Syst. Technol.*, vol. 20, no. 3, pp. 581-592, May 2012.  
 [22] H. Hao and L. Fangxing, "Sensitivity Analysis of Load-Damping Characteristic in Power System Frequency Regulation," *IEEE Trans. Power Syst.*, vol. 28, no. 2, pp. 1324-1335, May 2013.  
 [23] S. Weckx, R. D'Hulst, and J. Driesen, "Primary and Secondary Frequency Support by a Multi-Agent Demand Control System," *IEEE Trans. Power Syst.*, vol. 30, no. 3, pp. 1394-1404, May 2015.  
 [24] C.-C. Le-Ren, A. Luu Ngoc, L. Ta-Wei, and L. Wei-Jen, "Incorporating Demand Response With Spinning Reserve to Realize an Adaptive Frequency Restoration Plan for System Contingencies," *IEEE Trans. Smart Grid*, vol. 3, no. 3, pp. 1145-1153, Sept. 2012.

- [25] X. Zhao, J. Ostergaard, and M. Togeby, "Demand as Frequency Controlled Reserve," *IEEE Trans. Power Syst.*, vol. 26, no. 3, pp. 1062-1071, Aug. 2011.
- [26] P. J. Douglass, R. Garcia-Valle, P. Nyeng, J. Ostergaard, and M. Togeby, "Smart Demand for Frequency Regulation: Experimental Results," *IEEE Trans. Smart Grid*, vol. 4, no. 3, pp. 1713-1720, Sept. 2013.
- [27] Z. Changhong, U. Topcu, and S. H. Low, "Optimal Load Control via Frequency Measurement and Neighborhood Area Communication," *IEEE Trans. Power Syst.*, vol. 28, no. 4, pp. 3576-3587, Nov. 2013.
- [28] J. J. Ford, H. Bevrani, and G. Ledwich, "Adaptive load shedding and regional protection," *Int. J. Elect. Power Energy Syst.*, vol. 31, no. 10, pp. 611-618, Dec. 2009.
- [29] W. Gao and J. Ning, "Wavelet-Based Disturbance Analysis for Power System Wide-Area Monitoring," *IEEE Trans. Smart Grid*, vol. 2, no. 1, pp. 121-130, Mar. 2011.
- [30] M. Bayat, K. Sheshyekani, M. Hamzeh, and A. Rezaadeh, "Coordination of Distributed Energy Resources and Demand Response for Voltage and Frequency Support of MV Microgrids," *IEEE Trans. Power Syst.*, vol. 31, no. 2, pp. 1506-1516, Mar. 2016.
- [31] Z. Xu, R. Diao, S. Lu, J. Lian, and Y. Zhang, "Modeling of Electric Water Heaters for Demand Response: A Baseline PDE Model," *IEEE Trans. Smart Grid*, vol. 5, no. 5, pp. 2203-2210, Sept. 2014.
- [32] H. Bevrani, P. R. Daneshmand, P. Babahajyani, Y. Mitani, and T. Hiyama, "Intelligent LFC Concerning High Penetration of Wind Power: Synthesis and Real-Time Application," *IEEE Trans. Sustain. Energy*, vol. 5, no. 2, pp. 655-662, Oct. 2013.
- [33] R. Deng, Z. Yang, M. Y. Chow, and J. Chen, "A Survey on Demand Response in Smart Grids: Mathematical Models and Approaches," *IEEE Trans. Ind. Informat.*, vol. 11, no. 3, pp. 570-582, June 2015.
- [34] U.S. Energy Information Administration, annual energy review, 2010 [Online]. Available: <http://www.eia.gov/totalenergy/data/annual/#consumption>.
- [35] Yu-Qing Bao and Yang Li, "FPGA-Based Design of Grid Friendly Appliance Controller," *IEEE Trans. Smart Grid*, vol. 5, no. 2, pp. 924-931, Mar. 2014.
- [36] K. Samarakoon, J. Ekanayake, and N. Jenkins, "Reporting Available Demand Response," *IEEE Trans. Smart Grid*, vol. 4, no. 4, pp. 1842-1851, Dec. 2013.
- [37] M. Dong, P. C. M. Meira, W. Xu, and W. Freitas, "An Event Window Based Load Monitoring Technique for Smart Meters," *IEEE Trans. Smart Grid*, vol. 3, no. 2, pp. 787-796, June 2012.
- [38] C. Chen, J. Wang, and S. Kishore, "A Distributed Direct Load Control Approach for Large-Scale Residential Demand Response," *IEEE Trans. Power Syst.*, vol. 29, no. 5, pp. 2219-2228, Sept. 2014.
- [39] H. A. Aalami, M. P. Moghaddam, and G. R. Yousefi, "Demand response modeling considering interruptible/curtailable loads and capacity market programs," *Appl. Energy*, vol. 87, no. 1, pp. 243-250, Jan. 2010.
- [40] P. Palensky and D. Dietrich, "Demand Side Management: Demand Response, Intelligent Energy Systems, and Smart Loads," *IEEE Trans. Ind. Informat.*, vol. 7, no. 3, pp. 381-388, Aug. 2011.
- [41] Y. Q. Bao, Y. Li, Y. Y. Hong, and B. Wang, "Design of a hybrid hierarchical demand response control scheme for the frequency control," *Proc. IET Gen., Transm., Distrib.*, vol. 9, no. 15, pp. 2303-2310, Nov. 2015.
- [42] H. Hao, B. M. Sanandaji, K. Poolla, and T. L. Vincent, "Aggregate Flexibility of Thermostatically Controlled Loads," *IEEE Trans. Power Syst.*, vol. 30, no. 1, pp. 189-198, Jan. 2015.
- [43] M. Fekri Moghadam, M. Metcalfe, W. G. Dunford, and E. Vaahedi, "Demand Side Storage to Increase Hydroelectric Generation Efficiency," *IEEE Trans. Sustain. Energy*, vol. 6, no. 2, pp. 313-324, April 2015.
- [44] M. Dong, P. C. M. Meira, W. Xu, and C. Y. Chung, "Non-Intrusive Signature Extraction for Major Residential Loads," *IEEE Trans. Smart Grid*, vol. 4, no. 3, pp. 1421-1430, Sept. 2013.
- [45] N. Lu and Y. Zhang, "Design Considerations of a Centralized Load Controller Using Thermostatically Controlled Appliances for Continuous Regulation Reserves," *IEEE Trans. Smart Grid*, vol. 4, no. 2, pp. 914-921, June 2013.
- [46] S. A. Pourmousavi and M. H. Nehrir, "Real-Time Central Demand Response for Primary Frequency Regulation in Microgrids," *IEEE Trans. Smart Grid*, vol. 3, no. 4, pp. 1988-1996, Dec. 2012.
- [47] Z. Akhtar, B. Chaudhuri, and S. Y. Ron Hui, "Primary Frequency Control Contribution From Smart Loads Using Reactive Compensation," *IEEE Trans. Smart Grid*, vol. 6, no. 5, pp. 2356-2365, Sept. 2015.
- [48] K. Zhou and L. Cai, "A Dynamic Water-Filling Method for Real-Time HVAC Load Control Based on Model Predictive Control," *IEEE Trans. Power Syst.*, vol. 30, no. 3, pp. 1405-1414, May 2015.
- [49] M. Cheng, J. Wu, S. J. Galsworthy, C. E. Ugalde-Loo, N. Gargov, W. W. Hung, and N. Jenkins, "Power System Frequency Response From the Control of Bitumen Tanks," *IEEE Trans. Power Syst.*, vol. 31, no. 3, pp. 1769-1778, May 2016.
- [50] P. Kundur, *Power System Stability and Control*: 1st Ed., Englewood Cliffs, NJ, U.S.A.: McGraw-Hill, Jan. 1994.
- [51] H. Bevrani, F. Daneshfar, and R. P. Daneshmand, "Intelligent Power System Frequency Regulations Concerning the Integration of Wind Power Units," in *Wind Power Systems*. vol. 0, ed: Springer Berlin Heidelberg, 2010, pp. 407-437.
- [52] Report, I.C., "Dynamic Models for Steam and Hydro Turbines in Power System Studies," *IEEE Trans. Power App. Syst.*, vol. PAS-92, no. 6, pp. 1904-1915, Nov. 1973.



**Pouya Babahajiani** received the B.Eng. in electrical engineering from the University of Kurdistan, Sanandaj, Iran, in 2009, and the M.Sc. degree in control engineering from the Isfahan University of Technology, Isfahan, Iran, in 2012. He was a lecturer in the Department of Electrical and Computer Engineering, University of Kurdistan, Sanandaj, Iran, from 2010 to 2013. His research interests include demand response, robust and intelligent control and their applications in power electronic and power system industry.



**Qobad Shafiee** (S'13-M'15) received the M.S. degree in electrical engineering from the Iran University of Science and Technology, Tehran, Iran, in 2007, and the PhD degree in electrical engineering, Microgrids, from the Department of Energy Technology, Aalborg University, Aalborg, Denmark, in 2014. He was a lecturer in the Department of Electrical and Computer Engineering, University of Kurdistan, Sanandaj, Iran, from 2007 to 2011, where he is currently working as an Assistant Professor. From March 2014 to June 2014, he was a visiting scholar at the Electrical Engineering Department, University of Texas-Arlington, Arlington, TX, USA. He worked as a postdoctoral fellow with the Department of Energy Technology, Aalborg University, during 2015. His main research interests include modeling, energy management, and distributed control of Microgrids, smart grid control, and modeling and control of power electronic converters.



**Hassan Bevrani** (S'90-M'04-SM'08) received PhD degree in electrical engineering from Osaka University, Osaka, Japan, in 2004. From 2004 to 2014, he has worked as a post-doctoral fellow, senior research fellow, visiting professor, and professor with Kumamoto University (Japan), Queensland University of Technology (Australia), Kyushu Institute of Technology (Japan), Ecole Centrale de Lille (France) and Osaka University. Currently, he is working as a professor with the University of Kurdistan, Iran. He is the author of 5 books, 12 book chapters, and more than 200 journal/conference papers. His current research interests include power system frequency control, smart grid control, robust power system monitoring and control, and microgrid dynamics and control.