

**University of Kurdistan**

Dept. of Electrical and Computer Engineering

Smart/Micro Grid Research Center

[smgrc.uok.ac.ir](http://smgrc.uok.ac.ir)

## **Optimal Adaptive Droop Control for Effective Load Sharing in AC Microgrids**

A. Anvari-Moghadam, Q. Shafiee, J. C. Vasquez, and J. M. Guerrero

Published (to be published) in: Proceedings of the *42nd Annual Conference of the IEEE Industrial Electronics Society, IECON2016*

(Expected) publication date: Oct. 2016

**Citation format for published version:**

A. Anvari-Moghadam, Q. Shafiee, J. C. Vasquez, and J. M. Guerrero, (Oct. 2016). Optimal Adaptive Droop Control for Effective Load Sharing in AC Microgrids. In Proceedings of the *42nd Annual Conference of the IEEE Industrial Electronics Society (IECON2016)*, Florence, Italy, pp. xx-xx.

**Copyright policies:**

- Download and print one copy of this material for the purpose of private study or research is permitted.
- Permission to further distributing the material for advertising or promotional purposes or use it for any profit-making activity or commercial gain, must be obtained from the main publisher.
- If you believe that this document breaches copyright please contact us at [smgrc@uok.ac.ir](mailto:smgrc@uok.ac.ir) providing details, and we will remove access to the work immediately and investigate your claim.

# Optimal Adaptive Droop Control for Effective Load Sharing in AC Microgrids

Amjad Anvari-Moghadam<sup>1</sup>, Qobad Shafiee<sup>2</sup>, Juan C. Vasquez<sup>1</sup>, and Josep M. Guerrero<sup>1</sup>

<sup>1</sup>Department of Energy Technology, Aalborg University, Aalborg, Denmark  
(aam,juq,joz@et.aau.dk)

<sup>2</sup>Department of Electrical and Computer Engineering, University of Kurdistan, Sanandaj, Kurdistan, Iran  
(q.shafiee@uok.ac.ir)

**Abstract**—During the past few years, microgrids (MGs) have been becoming more attractive as effective means to integrate different distributed energy resources (DERs). To coordinate active and reactive power sharing among DERs, conventional droop control method is widely used as a decentralized control scheme. However, sharing powers among the sources based on the units' rated capacities is not an optimal solution in terms of economy and efficiency. In this paper, a new adaptive droop-based control strategy is proposed for AC MGs to optimally share MG load between corresponding units. The mentioned control strategy is developed in two levels. The upper control level is a mixed-objective optimization algorithm that provides optimal set-points for power generations considering system's constraints and goals, while the lower control level is responsible for tracking the reference signals coming from the upper level. To demonstrate the effectiveness of the proposed control strategy under different operating scenarios, simulation results in a benchmark MG are also presented.

**Index Terms**— AC microgrid, distributed generation, droop control, load sharing, multi-objective optimization.

## I. INTRODUCTION

As the integration of distributed generators (DGs) with power electronic interfaces continues to increase, the concept of Microgrid (MG) is becoming more popular [1]-[6]. These small-scale grids are heterogeneously composed of DGs, energy storage systems (ESS) and loads that can connect to the large power system through the Point of Common Coupling (PCC) or operate autonomously [7].

In conventional power systems, synchronous generators (SGs) are grid-forming units which have the task to provide a stable operating point, i.e., a synchronous frequency and a certain voltage level at all the buses in the network [8]. In inverter-based systems, e.g., inverter-intensive AC MG, this capability is provided by voltage source inverters (VSIs) [9]. The concept of droop control is often used in conventional power systems to maintain the desired system frequency by adjusting the rotational speed of SGs. This control strategy allows parallel generator operation to obtain load power sharing. Inspired hereby, the concept of droop control was proposed for parallel connected inverters [10], and later for AC MGs [11]. In MGs, droop control provides frequency and voltage regulation, and handles (active/reactive) power sharing among sources proportional to their power ratings [12].

Despite operational simplicity and decentralized structure, droop control has practical limitations: operational frequency/voltage deviation, poor reactive power sharing in the presence of distribution line impedances, and poor power quality performance in dealing with nonlinear loads, to name significant ones [13]-[15]. As MG sources respond to more power demand, onboard droop controllers, reduce their frequency/voltage to handle load sharing and prevent overload/overstress. Since frequency is a global variable, proportional active power sharing is obtained by the conventional P-f droop control. In this control strategy, droop coefficients are defined in proportion to sources' rated powers, thus sharing the load demands accordingly. Recently, lots of works have been introduced in the literature proposing adaptive droop control methods [16]-[21]. These works typically adjust the droop characteristics to mitigate any power/current mismatch, providing proportional load sharing. Existing solutions mainly propose adaptive droop for reactive power sharing in AC MGs or current sharing in DC systems considering effect of line impedance. However, no single work takes into account optimal solutions in terms of economy and efficiency for defining droop coefficient. This paper proposes an optimal adaptive droop method for AC microgrids. The proposed approach fine-tunes the P-f droop coefficients once any unexpected load change occurs or a decision time triggers. The optimal policy for such fine-tunings is derived from a mixed-objective optimization problem with regard to a meaningful balance between MG operating cost and loss minimization.

The remainder of the paper is organized as follows: Section II introduces the proposed optimal droop control strategy. Section III studies performance of the proposed controller for an AC microgrid, and Section IV concludes the paper.

## II. CONVENTIONAL DROOP CONTROL

To get an insight into the theory of a conventional droop-based control strategy, let's consider the problem of complex power transfer through a transmission line as one is shown in Fig. 1. Without loss of generality, the transmission line could be considered as an R-L circuit with the voltages at the terminals of the line being held constant.

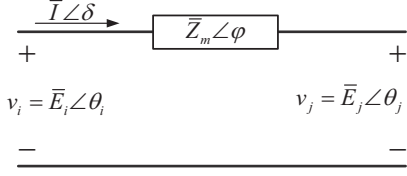

Figure 1. Power flow between two nodes through a line

based on the above definitions, the complex power flow from bus  $i$  to  $j$  is expressed as:

$$S_{ij} = P_{ij} + jQ_{ij} = v_i \left( \frac{v_i - v_j}{Z_m} \right)^* = \frac{\bar{E}_i}{Z_m e^{-j\varphi}} (\bar{E}_i - \bar{E}_j e^{j\theta}) \quad (1)$$

where  $\theta$  is the voltage angle difference between bus  $i$  and  $j$ . By breaking the total complex power into real and imaginary components, the real and reactive power flows through the line can be determined as follows:

$$P_{ij} = \frac{\bar{E}_i^2}{Z_m} \cos(\varphi) - \frac{\bar{E}_i \bar{E}_j}{Z_m} \cos(\theta + \varphi) \quad (2)$$

$$Q_{ij} = \frac{\bar{E}_i^2}{Z_m} \sin(\varphi) - \frac{\bar{E}_i \bar{E}_j}{Z_m} \sin(\theta + \varphi) \quad (3)$$

Further defining the line impedance to be  $Z_m = R_m + jX_m$ , the above equations can be rewritten as:

$$P_{ij} = \frac{\bar{E}_i}{R_m^2 + X_m^2} [R_m \bar{E}_i - \bar{E}_j \cos(\theta) + X_m \bar{E}_j \sin(\theta)] \quad (4)$$

$$Q_{ij} = \frac{\bar{E}_i}{R_m^2 + X_m^2} [X_m \bar{E}_i - \bar{E}_j \cos(\theta) - R_m \bar{E}_j \sin(\theta)] \quad (5)$$

Assuming that in a typical transmission line the inductance is much greater than the resistance, the following well-known equations can be derived:

$$P_{ij} \cong \frac{\bar{E}_i \bar{E}_j}{X_m} \sin(\theta) \quad (6)$$

$$Q_{ij} \cong \frac{\bar{E}_i^2}{X_m} - \frac{\bar{E}_i \bar{E}_j}{X_m} \cos(\theta) \quad (7)$$

If the power angle  $\theta$  is small, then the small angle formula can be used so that  $\sin(\theta) \approx \theta$  and  $\cos(\theta) \approx 1$ . Simplifying and rewriting the aforementioned equations gives:

$$\theta \cong \frac{X_m P_{ij}}{\bar{E}_i \bar{E}_j} \quad (8)$$

$$\bar{E}_i - \bar{E}_j \cong \frac{X_m Q_{ij}}{\bar{E}_i} \quad (9)$$

Based on (8)-(9), it can be easily observed that the power angle  $\theta$  is directly proportional to the real power while the voltage difference depends heavily on the reactive power. In other words, by controlling the real power it would be possible to adjust the power angle, and through reactive power control, voltage regulation can be achieved. In a droop-based control, the same procedure is adopted with the exception that each unit uses the frequency (instead of the power angle or phase angle), for controlling the active power flow. This issue comes from the fact that within a stand-alone system, the units are not aware of the initial phase values of other units. These observations lead to the common droop control equations [9]:

$$\omega_i = \omega^* - m_i (P_i - P_i^*) \quad (10)$$

$$v_i = v_i^* - n_i (Q_i - Q_i^*) \quad (11)$$

where  $\omega^*$  and  $v^*$  are the nominal values of generation unit frequency and output voltage respectively, and  $P^*$  and  $Q^*$  are the temporary set-points for the real and reactive power of the unit. In a similar manner,  $m$  and  $n$  are the active and reactive droop coefficients for the corresponding unit.

### III. OPTIMAL ADAPTIVE DROOP CONTROL

In a typical MG, unexpected supply–demand imbalances might change the system frequency rapidly and frequently. The frequency deviations could be even more severe if small inertia exists in the MG environment. To handle these issues suitably, there is an increasing need to develop a fast, efficient, reliable, and cost-effective solution to satisfy the needs of real-time application in MGs. Such a solution can be obtained using a two-level hybrid control strategy as illustrated in Fig. 2, which requires a centralized controller in the upper level and decentralized droop-based controllers at lower level.

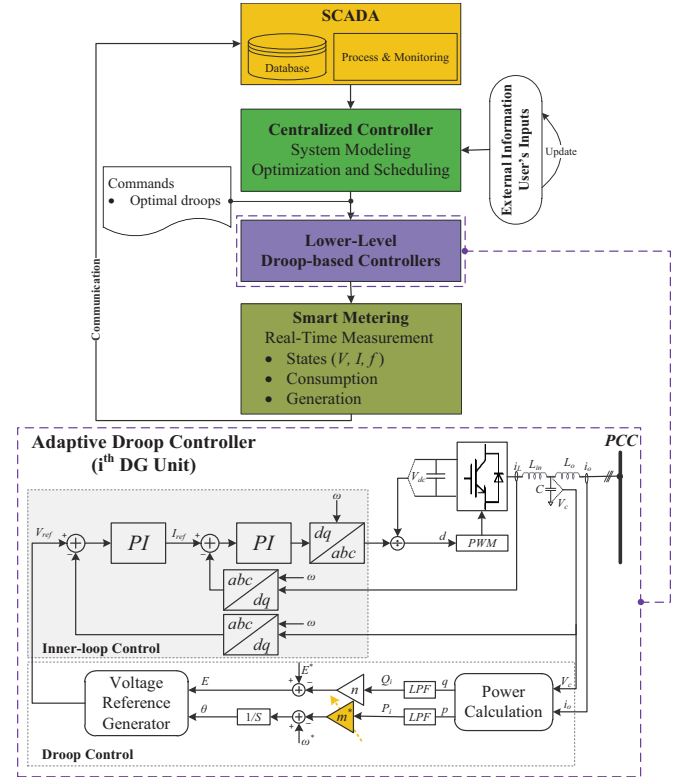

Figure 2. Two-level hybrid control strategy for optimal operation management of DG units

However, a reliable two-way communication network between the central controller and all the local ones is required. In our proposed hybrid structure, the centralized controller collects all the requisite information such as nodal voltages, frequency, generation and load conditions as well as cost functions and calculates the optimal power dispatch of controllable DG units ( $P_{G,i}^*$ ) based on the following mixed objective function and available constraints:

$$\begin{aligned}
& \text{Min } \{ \xi_1 \text{TOC}(t) + \xi_2 \text{TPL}(t) \} \\
& \text{s.t. } P_{G,i}^{\min} \leq P_{G,i}(t) \leq P_{G,i}^{\max}; \quad \forall i \in N_G \\
& \sum_{i=1}^{N_G} P_{G,i}(t) = P_{\text{Load}}(t) + \text{TPL}(t); \quad \forall t \in T
\end{aligned} \quad (12)$$

where  $\text{TOC}(t)$  and  $\text{TPL}(t)$  are the total operating cost and active power loss of the MG at each time step  $t$ , respectively and  $\xi_1$  and  $\xi_2$  are the weighting factors reflecting the significance of the mentioned terms from the MG operator's perspective. Similarly,  $P_{G,i}^{\min}$  and  $P_{G,i}^{\max}$  are the generation lower and upper bounds,  $P_{\text{load}}(t)$  is the MG load level at time step  $t$ , and  $N_G$  is the total number of generation units within the MG.  $\text{TOC}$  includes the operation and maintenance costs of corresponding units and can be calculated as:

$$\begin{aligned}
\text{TOC}(t) = & \sum_{i=1}^{N_G} \alpha_{oi} + \beta_{oi} P_{G,i}(t) + \gamma_{oi} P_{G,i}^2(t) \\
& + u_i(t) \cdot \left( \alpha_{si} + \beta_{si} \left( 1 - e^{-\frac{t_{\text{off}}}{\tau_i}} \right) \right) \cdot (u_i(t) - u_i(t-1))
\end{aligned} \quad (13)$$

where,  $\alpha_{oi}$ ,  $\beta_{oi}$  and  $\gamma_{oi}$  are the coefficients of the convex quadratic cost function and  $\alpha_{si}$ , and  $\beta_{si}$  are the coefficients for the start-up/shut-down cost of corresponding units.  $\tau_i$  is the thermal time constant and  $u_i$  is the on/off state of the  $i$ -th unit.  $t_{\text{off}i}$  also denotes the time the unit was cooled. It is noteworthy that  $\text{TPL}$  can be determined based on the following formula:

$$\text{TPL}(t) = \sum_{m=1}^k PL_m(t) \quad (14)$$

where  $k$  is the number of power lines in the MG and  $PL_m$  is the active power loss over the  $k$ -th line connected between nodes  $i$  and  $j$ :

$$PL_m = P_{ij} + P_{ji} = \frac{1}{Z_m^2} \left[ R_m (\bar{E}_i^2 + \bar{E}_j^2) - 2\bar{E}_i \bar{E}_j R_m \cos \theta_{ij} \right] \quad (15)$$

Having found the optimal solution to (12), centralized controller will broadcast the results as new set-points to dedicated decentralized droop-based controllers for adjusting the unit droop accordingly:

$$m_i^* = \frac{m_i \cdot P_{G,i}}{P_{G,i}^*}; \quad \forall i \in N_G \quad (16)$$

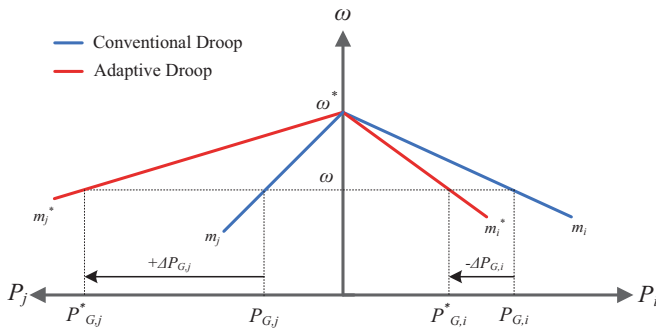

Figure 3. Adaptive droop characteristic of active power regulation

where  $m_i^*$  is the modified active droop coefficient of  $i^{\text{th}}$  DG unit based on the new generation set-point as shown in Fig. 3.

It should be noted that the reactive load is also shared between the units based on their rated power capacities and controlled locally by conventional droop control methodology.

#### IV. RESULTS AND DISCUSSIONS

An inverter-intensive AC microgrid test bench, shown in Fig. 4, is considered to study performance of the proposed control methodology. The case study consists of four DG units connected to different nodes and operated based on scheduled real and reactive power references, several local and distant loads, and associated power lines. It is assumed that all four DGs have the same rated power. Rated voltage of the system is 230 V with the frequency of 50 Hz. LCL filters are installed at the inverters' outputs to reduce the switching-induced harmonics. Other electrical and control parameters of the underlying system are tabulated in details in Table I. It is also notable to say that all of the algorithms and simulations are carried out on a PC with an Intel i7-3740QM chip, running Windows 7(64 bit) with MATLAB-SIMULINK, and GAMS.

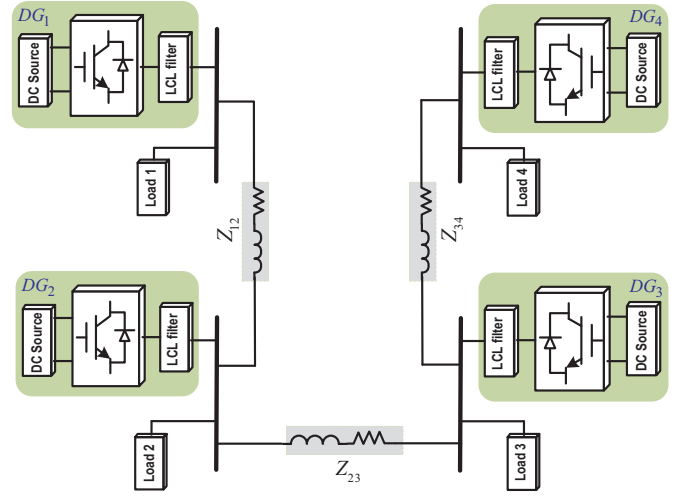

Figure 4. A four bus AC microgrid test bench

TABLE I  
MICROGRID TEST BENCH ELECTRICAL AND CONTROL PARAMETERS

Electrical Parameters					
Symbol	Quantity	Value			
$V_{\text{dc}}$	DC voltage	650 V			
$E^{\text{ref}}$	MG voltage amplitude	325 V			
$f$	MG frequency	50 Hz			
$C$	LCL filter capacitance	25 $\mu\text{F}$			
$L$	LCL filter inductance	1.8 mH			
$L_o$	LCL filter impedance	1.8 mH			
$Z_i$	Load 1, 2, 3, 4	$150 + j314 \Omega$			
$Z_{12}$	Line impedance 1, 2	$R_{12} = 1.2 \Omega, L_{12} = 5.4 \text{ mH}$			
$Z_{23}$	Line impedance 2, 3	$R_{23} = 0.4 \Omega, L_{23} = 1.8 \text{ mH}$			
$Z_{34}$	Line impedance 3, 4	$R_{34} = 0.8 \Omega, L_{34} = 3.2 \text{ mH}$			
Control Parameters					
$P_{\text{max}}$	Rated active power	2200 kW			
$Q_{\text{max}}$	Rated reactive power	1100 VAr			
$m$	$P$ - $\omega$ droop coefficient	0.0002			
$n$	$Q$ - $v$ droop coefficient	0.01			
Cost Functions					
Symbol	Quantity	DG1	DG2	DG3	DG4
$\alpha_i$	Cost function	0.403	0.380	0.650	0.301
$\beta_i$	coefficients	0.018	0.027	0.015	0.029
$\gamma_i$	coefficients	0.420	0.240	0.521	0.310
$\alpha_{si}$	Startup/shut-down cost	0.600	0.510	0.901	0.400

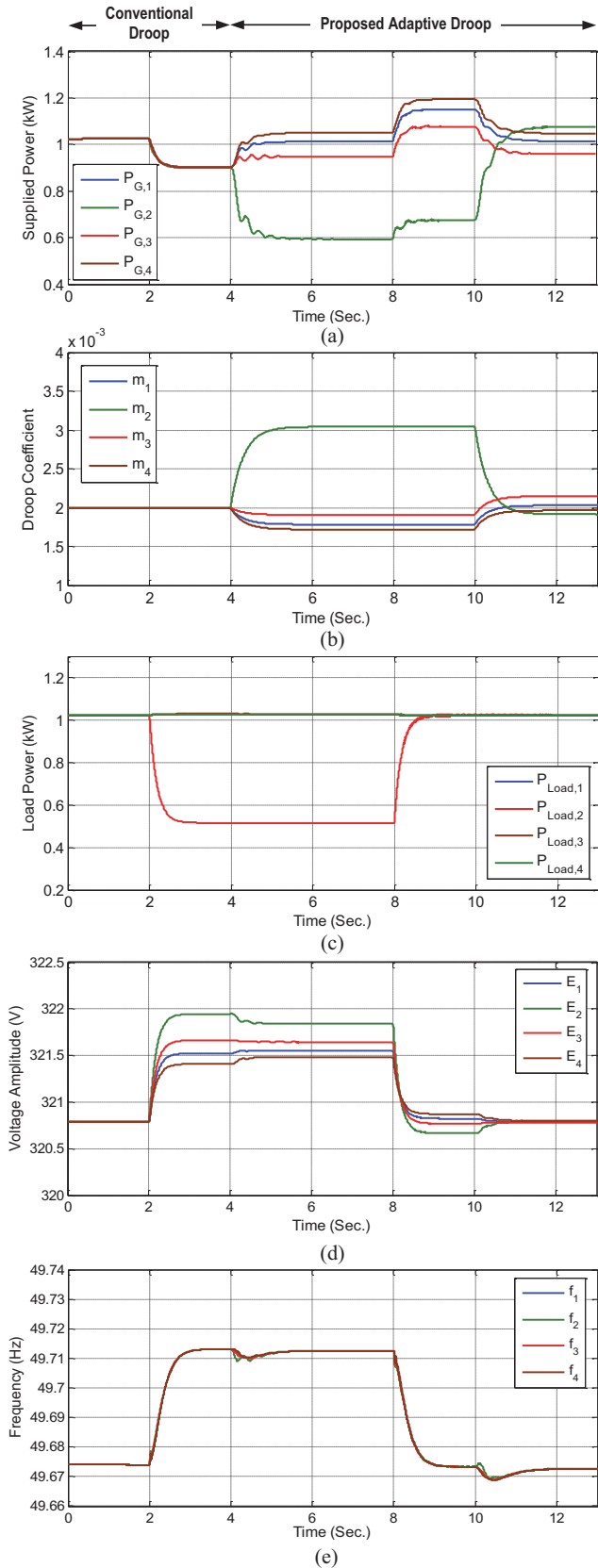

Figure 5. Controller performance based on the mixed objective function: (a) Supplied active power, (b) Droop coefficients, (c) Load power, (d) Voltage amplitude, (e) frequency

Performance of the proposed approach is evaluated under different objective functions in comparison with the conventional droop control through subsequent studies. The controller response is examined under frequent load changes. In all the studies, once a disturbance occurs, the proposed controller is triggered after 2 second. Figure 5 shows the simulation results for operation management of the DG units with regard to the mixed objective function as stated in (13). In this case, the centralized controller aims at finding the optimal  $P$ - $f$  droop coefficients in a way to minimize both total operating cost and active power loss of the MG. The controller performance is verified under multiple load changes where 50% of the local load at the second bus is unplugged at  $t = 2$  s and plugged back in at  $t = 8$  s, as shown in Fig. 5(c). For  $t < 4$  s the conventional droop controller is effective. Due to equal power rates, droop coefficients are chosen to be the same. Accordingly, the active powers supplied by the DGs are properly shared. This is because frequency is a global variable in the whole system. Activation of the proposed controller at  $t = 4$  s, updates the droop coefficients (see Fig. 5(b)) in the way that optimal power sharing between the DGs is assured. It can be seen that after decreasing the local load at bus 2, DG 2 injects almost the required local demand, i.e., 0.5 kW, to avoid losses in the system. The difference between the supplied power from DG2 and local load demand is due to considering operating cost as the other objective function. Frequency and voltage amplitude of the system are depicted in Fig. 5(d) and 5(e). As expected, there exist deviations from the nominal values in both frequency and voltage. However, they are still inside the acceptable range. It is noteworthy that secondary control loop often used to eliminate these deviations produced by droop control.

The efficacy of the proposed controller is practiced then for each objective function separately, i.e., cost and loss minimization, and the results are shown in Figs. 6 and 7. Figure 6 shows the controller response where the droop coefficients are calculated to minimize the active power loss in the system. The load change remains the same as the previous study. As can be seen, the adaptive droop imposes the DGs to supply their local loads so as to avoid losses over lines. When operating cost minimization is defined as the only objective function (see Fig. 7), DGs are dispatched in an economic way taking into account the cost function parameters listed in Table I. Comparing the results in Figs. 6 and 7, one can note that the optimal set-points and supplied powers by the DGs are totally different and greatly depend on operator's prospective. For example in a cost-effective approach, the operational cost of the system is mitigated by about 4% during the examined time; however the system's loss is increased by 7% compared to a loss-effective dispatch.

## V. CONCLUSION

In this paper, an adaptive droop-based control methodology for optimal power sharing was proposed for power electronics interfaced DG units in AC microgrids. The proposed control strategy was realized through a two-level structure with a centralized controller in the upper level and decentralized droop-based controllers at lower level. A mixed-objective optimization algorithm was also incorporated in the upper level to provide optimal droop coefficients for DG units considering different system's objectives and constraints. To

demonstrate the effectiveness of the proposed control strategy under different operating scenarios and objectives, a number of computer simulations were carried out and related results were compared to those by conventional droop control methods. The comparative study showed that by using a coordinated adaptive droop-based control method, not only the load power is shared among the DGs economically, but also active power losses are minimized through the MG.

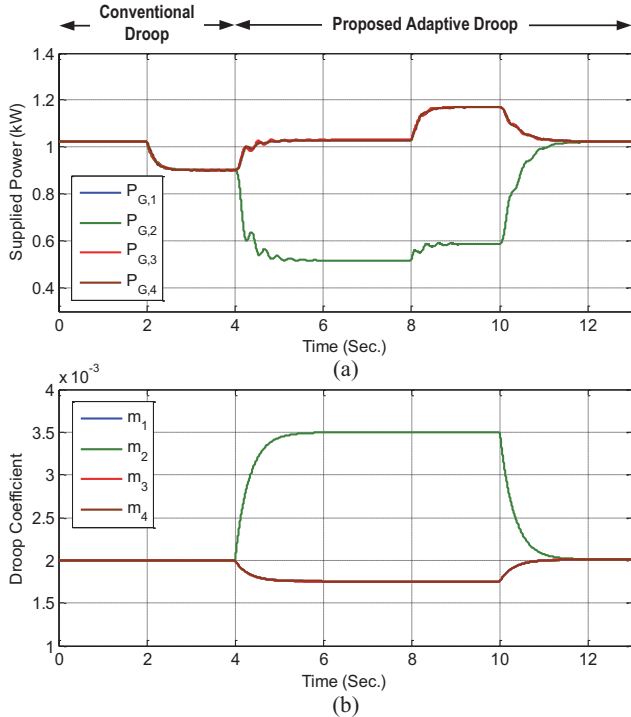

Figure 6. Controller performance based on the loss minimization objective: (a) Supplied active power, (b) Droop coefficients

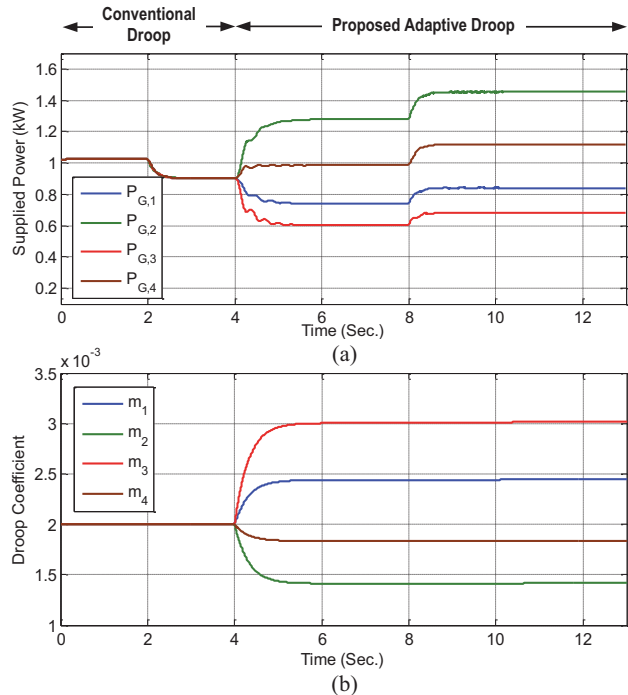

Figure 7. Controller performance based on the cost minimization objective: (a) Supplied active power, (b) Droop coefficients

## REFERENCES

- [1] N. Hatziargyriou, H. Asano, R. Iravani, and C. Marnay, "Microgrids," *IEEE Power Energy Mag.*, vol. 5, no. 4, pp. 78–94, 2007.
- [2] J. a P. Lopes, C. L. Moreira, and a. G. Madureira, "Defining control strategies for microgrids islanded operation," *IEEE Trans. Power Syst.*, vol. 21, no. 2, pp. 916–924, 2006.
- [3] A. Anvari-Moghaddam, A. R. Seifi, T. Niknam, "Multi-operation management of a typical microgrid using Particle Swarm Optimization: A comparative study," *Renew. Sust. Energy Reviews*, vol. 16, no. 2, pp. 1268–1281, 2012.
- [4] D. E. Olivares, A. Mehrizi-Sani, A. H. Etemadi, C. a. Cañizares, R. Iravani, M. Kazerani, A. H. Hajimiragha, O. Gomis-Bellmunt, M. Saeedifard, R. Palma-Behnke, G. a. Jiménez-Estévez, and N. D. Hatziargyriou, "Trends in microgrid control," *IEEE Trans. Smart Grid*, vol. 5, no. 4, pp. 1905–1919, 2014.
- [5] F. Katiraei, R. Iravani, N. Hatziargyriou, and A. Dimeas, "Microgrids management," *IEEE Power Energy Mag.*, vol. 6, no. 3, pp. 54–65, 2008.
- [6] A. Anvari-Moghaddam, T. Dragicevic, J. C. Vasquez, J. M. Guerrero, "Optimal Utilization of Microgrids Supplemented with Battery Energy Storage Systems in Grid Support Applications," *Proc. 1<sup>st</sup> IEEE Int. Conf. DC Microgrids*, Atlanta, June 7–10, 2015.
- [7] "IEEE Standard for Interconnecting Distributed Resources with Electric Power System," *IEEE Std 1547-2003*, pp. 1–28, 2003.
- [8] P. Kundur, "Power system stability and control," New York: McGraw-Hill, 1994.
- [9] J. Rocabert, A. Luna, F. Blaabjerg, and I. Paper, "Control of Power Converters in AC Microgrids," *IEEE Trans. Power Electron.*, vol. 27, no. 11, pp. 4734–4749, 2012.
- [10] M. C. Chandorkar, D. M. Divan, and R. Adapa, "Control of parallel connected inverters in standalone ac supply systems," *IEEE Trans. Ind. Appl.*, vol. 29, no. 1 pt 1, pp. 136–143, 1993.
- [11] J. M. Guerrero, M. Chandorkar, T. Lee, and P. C. Loh, "Advanced Control Architectures for Intelligent Microgrids—Part I: Decentralized and Hierarchical Control," *IEEE Trans. Ind. Electron.*, vol. 60, no. 4, pp. 1254–1262, 2013.
- [12] J. M. Guerrero, J. C. Vásquez, J. Matas, M. Castilla, and L. García de Vicuña, "Control strategy for flexible microgrid based on parallel line-interactive UPS systems," *IEEE Trans. Ind. Electron.*, vol. 56, no. 3, pp. 726–736, 2009.
- [13] J. Hu, J. Zhu, D. G. Dorrell, and J. M. Guerrero, "Virtual flux droop method - A new control strategy of inverters in microgrids," *IEEE Trans. Power Electron.*, vol. 29, no. 9, pp. 4704–4711, 2014.
- [14] J. W. Simpson-Porco, F. Dörfler, and F. Bullo, "Voltage stabilization in microgrids via quadratic droop control," *Proc. IEEE Conf. Decis. Control*, pp. 7582–7589, 2013.
- [15] J. He and Y. W. Li, "Analysis, design, and implementation of virtual impedance for power electronics interfaced distributed generation," *IEEE Trans. Ind. Appl.*, vol. 47, no. 6, pp. 2525–2538, 2011.
- [16] Q. Shafiee, J. M. Guerrero, and J. C. Vasquez, "Distributed secondary control for islanded microgrids—a novel approach," *IEEE Trans. Power Electron.*, vol. 29, no. 2, pp. 1018–1031, 2014.
- [17] V. Nasirian, S. Member, A. Davoudi, and F. L. Lewis, "Distributed Adaptive Droop Control for DC Microgrids," *IEEE Trans. Energy Convers.*, vol. 29, no. 4, pp. 1147–1152, 2014.
- [18] Y. A. R. I. Mohamed and E. F. El-Saadany, "Adaptive decentralized droop controller to preserve power sharing

stability of paralleled inverters in distributed generation microgrids,” *IEEE Trans. Power Electron.*, vol. 23, no. 6, pp. 2806–2816, 2008.

- [19] S. Augustine, M. K. Mishra, and N. Lakshminarasamma, “Adaptive Droop Control Strategy for Load Sharing and Circulating Current Minimization in Standalone DC Low-voltage Microgrid,” *IEEE Transactions Energy Convers.*, vol. 6, no. 1, pp. 132–141, 2015.
- [20] Q. Shafiee, V. Nasirian, J. M. Guerrero, F. L. Lewis, and A. Davoudi, “Team-oriented Adaptive Droop Control for Autonomous AC Microgrids,” *Proc. 40th Annu. Conf. IEEE Ind. Electron. Soc. IECON*, 2014, pp. 1861 – 1867.
- [21] J. Kim, J. M. Guerrero, P. Rodriguez, R. Teodorescu, and K. Nam, “Mode adaptive droop control with virtual output impedances for an inverter-based flexible AC microgrid,” *IEEE Trans. Power Electron.*, vol. 26, no. 3, pp. 689–701, 2011.