



**University of Kurdistan**

Dept. of Electrical and Computer Engineering

*Smart/Micro Grid Research Center*

[smgrc.uok.ac.ir](http://smgrc.uok.ac.ir)

## **An intelligent based power system load shedding design using voltage and frequency information**

H. Bevrani, A. G. Tikdari, T. Hiyama

Published (to be published) in: Int. Conf. on Modeling, Identification and Control-ICMIC, Okayama, Japan.

(Expected) publication date: 2010

### **Citation format for published version:**

H. Bevrani, A. G. Tikdari, T. Hiyama (2010) An intelligent based power system load shedding design using voltage and frequency information. Int. Conf. on Modeling, Identification and Control-ICMIC, Okayama, Japan.

### **Copyright policies:**

- Download and print one copy of this material for the purpose of private study or research is permitted.
- Permission to further distributing the material for advertising or promotional purposes or use it for any profit-making activity or commercial gain, must be obtained from the main publisher.
- If you believe that this document breaches copyright please contact us at [smgrc@uok.ac.ir](mailto:smgrc@uok.ac.ir) providing details, and we will remove access to the work immediately and investigate your claim.

## An Intelligent Based Power System Load Shedding Design Using Voltage and Frequency Information

H. Bevrani, *Senior Member, IEEE*, A. G. Tikdari, *Member, IEEE*, T. Hiyama, *Senior Member, IEEE*

**Abstract**—This paper addresses a new intelligent based emergency power system control strategy. To design an optimal load shedding scheme, both system frequency and voltage characteristics are considered. A new tool for post-contingency dynamic behavior and stability analysis is introduced. The proposed methodology is supplemented by nonlinear simulations to examine the effectiveness against serious contingencies.

### I. INTRODUCTION

The distributed power fluctuation (due to using of variable generations) negatively contributes to the power imbalance, frequency and voltage deviations. Significant disturbance can cause under/over frequency/voltage relaying and disconnect some lines, loads and generations. Under unfavorable conditions, this may result in a cascading failure and system collapse [1].

Load shedding (LS) is an emergency control action to ensure system stability, by curtailing system load. The emergency LS would only be used if the frequency/voltage falls below a specified frequency/voltage threshold. Typically, the LS protects the system against excessive frequency or voltage decline by attempting to balance real and reactive power supply and demand. Most common LS schemes are under-frequency LS (UFLS) schemes, which involve shedding predetermined amounts of load if the frequency drops below specified frequency thresholds. The under-voltage LS (UVLS) schemes, in a similar manner, are used to protect against excessive voltage decline.

To prevent the post-load shedding problems and over loading, the location bus for the LS will be determined based on the load importance, cost, and distance to the contingency location. The number of LS steps, amount of load that should be shed in each step, the delay between the stages, and the location of shed load are the important objects that should be determined in an LS algorithm.

An LS scheme is usually composed of several stages. Each stage is characterized by frequency/voltage threshold, amount of load, and delay before tripping. The objective of an effective LS scheme is to curtail a minimum amount of load, and provide a quick, smooth, and safe transition of the

system from an emergency situation to a normal equilibrium state [2].

There are various types of UFLS/UVLS schemes discussed in literature and applied by the electric utilities around the world. A classification divides the existing schemes into *static* and *dynamic* (or *fixed* and *adaptive*) LS types. Static LS curtails the constant block of load at each stage, while dynamic LS curtails a dynamic amount of load by taking into account the magnitude of disturbance and dynamic characteristics of the system at each stage. Although the dynamic LS schemes are more flexible and have several advantages, most real-world LS plans are of static type [1].

There are two basic paradigms for LS: a *shared* LS paradigm, and a *targeted* LS paradigm. The first paradigm appears in the well-known UFLS schemes, and the second paradigm in some recently proposed wide-area LS approaches. Using simulations for a multi-area power system, it is easy to illustrate the difference between these two paradigms, following generation loss in one area [3].

The most existing LS schemes use only voltage or frequency via UVLS or UFLS methodologies. The under-frequency and under-voltage relays are working in the power system without any coordination. In this paper, the necessity of considering both voltage and frequency indices to achieve a more effective and comprehensive LS strategy in a power system is illustrated. An artificial neural network based LS methodology considering both system frequency and voltage characteristics is addressed. Finally, the proposed emergency control strategy is supplemented by simulations in a power system case study.

### II. THE NEED FOR CONSIDERING BOTH VOLTAGE AND FREQUENCY

Because of wide range of contingencies in the power system, only use of voltage and frequency indices is not sufficient to arrest all post contingency conditions. The most LS schemes proposed so far used voltage and frequency parameters, separately and also, the under-frequency and under-voltage relays are working in the power system without any coordination. The individual use of these indices may be also not reliable/effective, and may even lead to the over load shedding problems. The coordination between UFLS and UVLS schemes is initially difficult and may be impossible in many situations.

Manuscript received January 2, 2010.

H. Bevrani and A. G. Tikdari are with the Dept. of Electrical and Computer En., University of Kurdistan, Sanandaj, Iran. Currently, H. Bevrani is a visiting professor at Kumamoto University, Japan (Corresponding author e-mail: bevrani@ieee.org).

T. Hiyama is with Dept. of Electrical Eng., Kumamoto University, Kumamoto, Japan (e-mail: hiyama@cs.kumamoto-u.ac.jp).

Studying on the UFLS is often done using the system frequency response models. The impact of voltage variation on the frequency deviation is not considered in these models. Furthermore, the UVLS methods that proposed so far for adjusting the under-voltage relays, do not consider the frequency behavior. While, as illustrated later, these two parameters (voltage and frequency) are not independent. The dependency between voltage and frequency will affect LS performance. These impacts are considerable in the presence of wind turbines. Therefore, an algorithm that uses these parameters simultaneously for making load shedding decisions will be more reliable and effective than the conventional schemes. A preliminary work on this issue is given in [4].

Here, for the sake of dynamic simulations and to describe/examine the above explanations, an updated version of the IEEE nine-bus power system is considered as a case study system. The test system is shown in Fig. 1. Simulation data and system parameters are available in [5].

Some test scenarios are considered to demonstrate the necessity of considering both voltage and frequency data in an effective load shedding scheme. Fig. 2 shows the voltage and frequency deviations for two different LS scenarios following the same contingency. In these tests, G1 is tripped at 10s. In scenario 1, only 9% of total system active power is curtailed, while in scenario 2, in addition to 9% active power, 9% of total reactive power is also discarded. Both scenarios shed the load when the frequency falls below 59.7Hz as used in some existing LS standards. Considering the frequency and voltage behavior in the performed two scenarios, some important points are achieved.

A majority of published research on the under frequency load shedding, consider only the active part of load. While by considering the reactive power part, frequency decline to be affected, as shown in Fig. 2. Furthermore, in the actual power system, the loads contain both active and reactive parts. It is noteworthy that P-Q coupling (coupling between active and reactive part of load) can significantly affect the LS schemes.

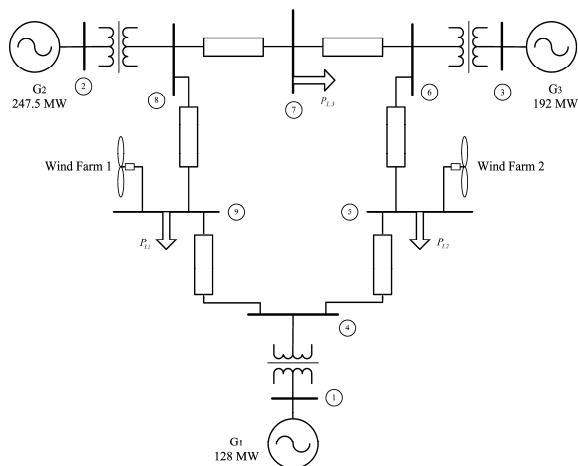

Fig. 1. Single line diagram of the updated nine-bus test system.

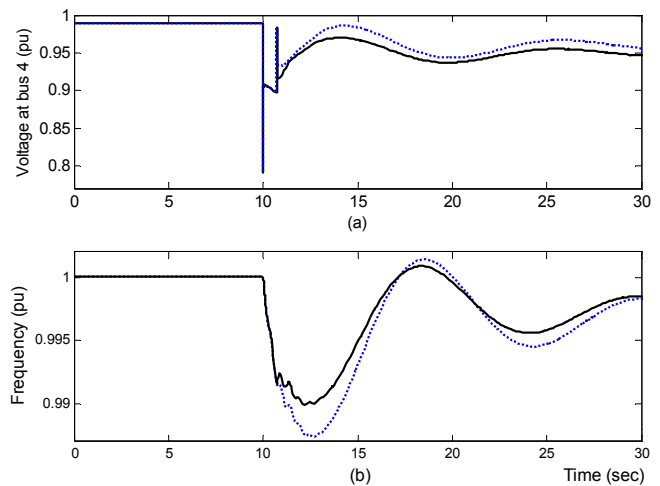

Fig. 2. System response for LS scenario 1 (solid) and scenario 2 (dotted); a) voltage deviation, b) frequency deviation.

Figs. 2a and 2b do not show which case is more effective. Fig. 2a illustrates a better performance for scenario 2; while, Fig. 2b shows an inverse result. This simulations show that by individual monitoring/using of frequency and voltage there is no guaranty to achieve an effective LS strategy. Case 1 is a sample of UFLS schemes that does not consider the voltage variation impacts.

Fig. 3 shows the frequency and voltage at bus 9 following outage of lines 4-9. Fig. 4 demonstrates the system response following outage of lines 8-7 and 8-9. As shown in these figures, the power system frequency behavior is in an opposite direction of the voltage behavior.

In [6,7], it is shown that the gradient of frequency decline depends on the amount of mechanical and electrical power mismatch. The frequency drop events are triggered by mechanical power reduction (generation loss) or electrical power increasing (load increasing). The under-frequency and under-voltage relays are working in the power system without any coordination. To arrest the frequency decline, a UFLS scheme may be used. A UFLS scheme sheds a portion of load demand when the frequency decline reaches the predetermined thresholds. Here, the impact of voltage behavior on the frequency variation is neglected.

On the other hand, following a generation loss disturbance, the voltage reduction will be experienced. Thus the implemented UVLS schemes throughout the power system attempt to restore the power system voltages. It can be easily shown that the voltage improvement leads to the increasing of load active power injection [8]. This behavior causes that the value of mismatch will be not as less as value predicted by UFLS scheme. Therefore, the frequency decline is going to be larger than its expected value.

This study shows that to design an optimal LS plan, it is necessary to consider both voltage and frequency indices.

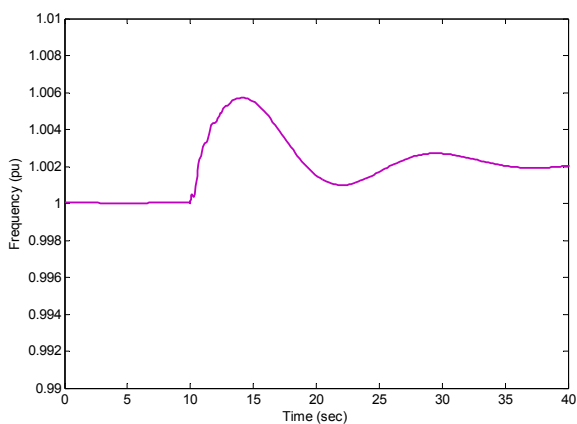

(a)

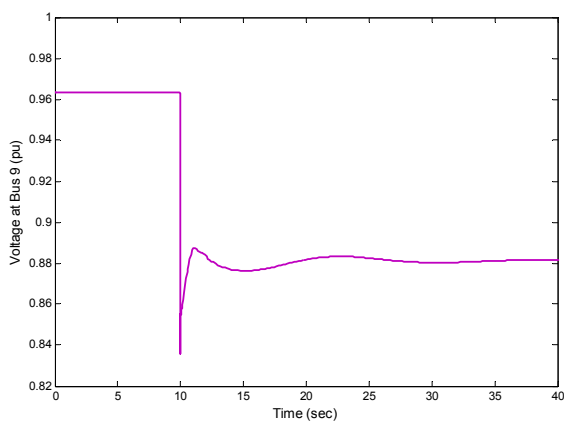

(b)

Fig. 3. System response following loss of line 4-9; a) frequency, and b) voltage, at bus 9.

### III. INTELLIGENT BASED EMERGENCY CONTROL SCHEME

#### A. Overall Framework

A new intelligent based power system emergency control considering voltage and frequency characteristics is proposed. The developed emergency control scheme is summarized in Fig. 5. A sever contingency triggers the proposed load shedding algorithm considering both voltage and frequency. For this purpose, a trained neural network (ANN) uses the measured tie-line active/reactive powers to estimate the system P-V curve. The amount of load should be shed is immediately computed using an estimated P-V curve.

The proposed ANN is a three layer back-propagation neural network. The activation functions for the hidden layers are in form of tangent-sigmoid function, and the output activation functions are linear. The ANN first should be trained to predict the system P-V curve. The inputs of ANN are the severe contingency firing command, and the tie-line active and reactive powers before the related event.

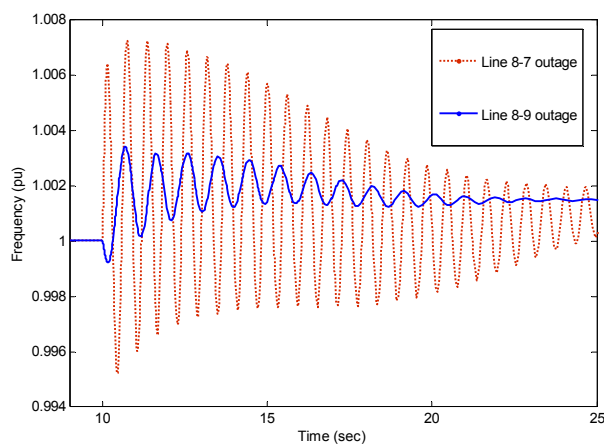

(a)

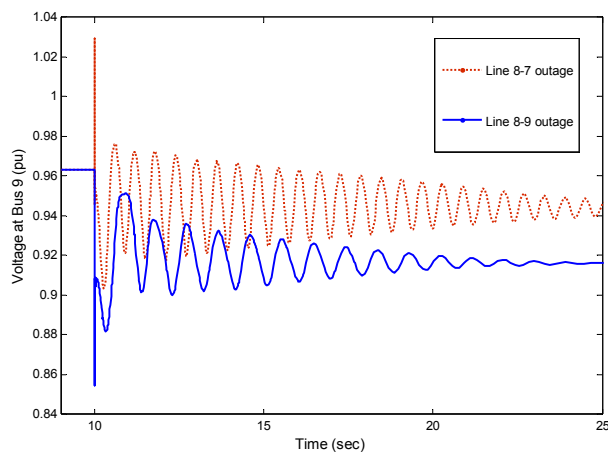

(b)

Fig. 4. System response following two disturbance scenarios; a) frequency, and b) voltage, at bus 9.

The ANN outputs are the coefficients of a fourth degree polynomial function that estimate the P-V curve. Since, the ANN is designed to predict the P-V curve for only severe contingencies, generation of training data is not so time consuming.

The estimated PV curve is used to determine the amount of load that should be shed to move the operating point into a desirable region. Finally, an optimal load shedding algorithm is used to shed amount of load in the assigned steps based on simultaneous using of voltage and frequency indices. The cumulative amount of loads that should be shed is limited by the determined value in the previous step. To assign the first step of load shedding, the initial rate of frequency change [9] is used to determine the amount of load that should be shed.

Using the produced P-V curve, the amount of load that should be shed could be calculated by the amount of load needed to achieve a minimum permissible power system voltage stability margin.

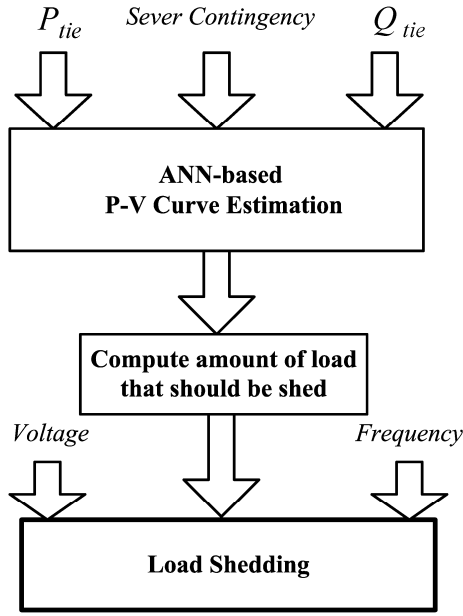

Fig. 5 The proposed intelligent based emergency control scheme.

### B. A New Tool for Post-contingency Dynamic Analysis

As mentioned, for the emergency control purposes, voltage and frequency are two suitable observable variables that could illustrate the state of system following an event. Fig. 6 shows the trajectory of the system states in the voltage-frequency plane, following a contingency with two scenarios: unstable trajectory, and stabilized trajectory using an LS plan. The states that used in this trajectory are  $\Delta f$  and  $\Delta V$ , represented in the following complex element.

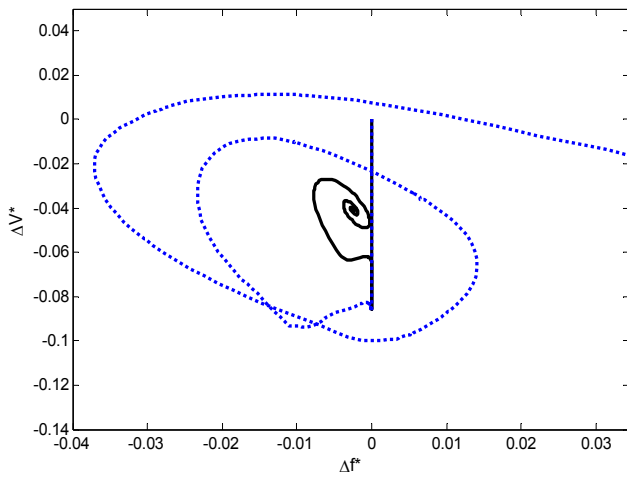

Fig. 6 Phase trajectory for post-contingency stability analysis; stable (solid) and unstable (dotted) post-contingencies.

$$S = \Delta f^* + j \Delta v^* \quad (1)$$

and,

$$\Delta f^* = \frac{\Delta f}{f_0}, \quad \Delta v^* = \frac{\Delta v}{v_0} \quad (2)$$

where, the  $f_0$  and  $v_0$  are the frequency and voltage before contingency. To design a new LS algorithm based on the above state variables, some threshold boundaries should be defined instead of threshold values that are used in the conventional LS algorithms.

One may suggest the circular boundaries. But since the threshold movement sizes in two directions (the UFLS and the UVLS) are not the same, the elliptical boundaries are much better.

As shown in Fig. 7, each LS step can be determined by an ellipse and when the phase trajectory reaches to each ellipse, the corresponding LS step will be triggered. Fig. 7 shows the LS steps on the phase trajectory plan in the case of losing G2, the largest generator in the test system. The time delay between steps should be added to the LS algorithm. The voltage and frequency may need to pass through a low pass filter before entering into the algorithm. Existing practical constraints should be also, considered in the proposed scheme.

The initial conditions at time of each LS step are an important factor to obtain a more effective protection plan. For example, shedding the load in the conditions that voltages of the buses are above their pre-contingency values may result more bad circumstance. That is why, in the proposed algorithm, the loads are allowed to be shed only at the third quarter of the phase trajectory plane. In order to prevent shedding of load in the voltage dip conditions a specific margin must be considered.

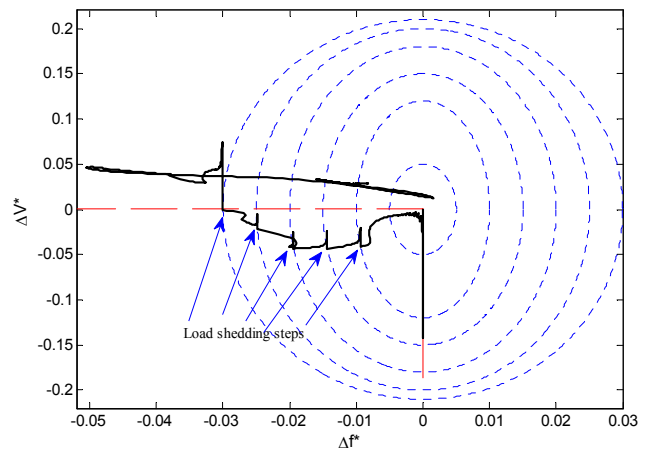

Fig. 7 The LS dynamics using new analysis tool.

#### IV. NONLINEAR SIMULATION RESULTS

Following loss of G2, the LS steps and the amount of shaded load in each step are illustrated in Fig. 8. As shown in this figure, the cumulative load that should be shed is fixed to 96MW. Fig. 9 shows the system voltage response at bus 4. The new LS scheme is compared with the conventional UFLS. It is shown that the new LS scheme is more efficient to prevent over load shedding and over voltage conditions after running the algorithm. Fig. 10 shows the system voltage and frequency deviation following application of the proposed emergency control strategy.

#### V. CONCLUSION

A new intelligent based power system emergency control scheme is proposed. The necessity of considering both system frequency and voltage indices to design an effective LS algorithm is shown. Then, an artificial neural network (ANN) based emergency control scheme is designed, and a new tool for post-contingency stability analysis is introduced.

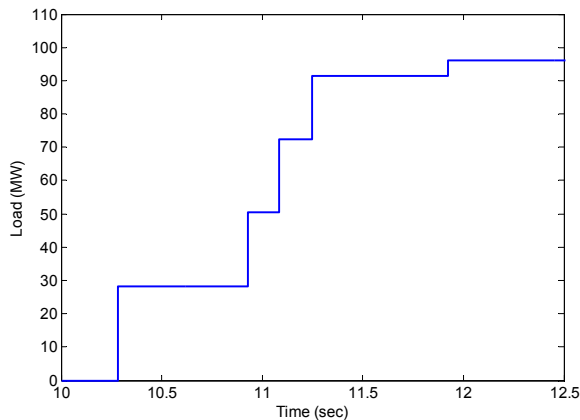

Fig. 8 The LS steps and amount of load that should be shed in each step in the case of G2 outage.

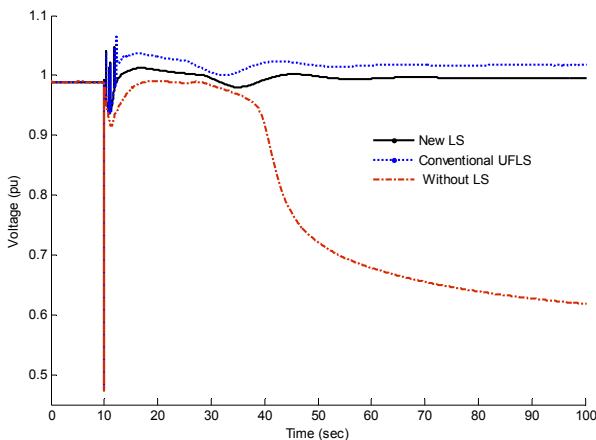

Fig. 9 Bus 4 voltage using different LS schemes following loss of G2.

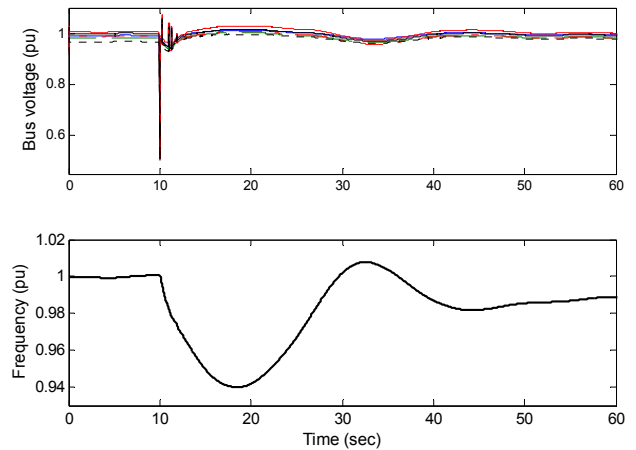

Fig. 10 System voltage and frequency deviation following loss of G2 and applied LS strategy.

The ANN structure is used to estimate the post-contingency power-voltage (P-V) curve, and finally, the results are used to run the developed optimal LS algorithm. The proposed emergency control scheme and discussions are supplemented by computer nonlinear simulations on an updated version of IEEE 9-bus test system.

#### REFERENCES

- [1] H. Bevrani, *Robust Power system Frequency Control*, New York: Springer, 2009.
- [2] C. Concordia, et al., "Load shedding and on an isolated system," *IEEE Trans on Power Sys*, vol. 10, no. 3, 1995, pp. 1467-72.
- [3] J. J. Ford, H. Bevrani, G. Ledwich, "Adaptive Load Shedding and Regional Protection", *International Journal of Electrical Power and Energy Systems*, vol. 31, 2009, pp. 611-618.
- [4] H. Bevrani, T. Hiyama, and A. G. Tikdari, "On the necessity of considering both voltage and frequency in effective load shedding scheme," *IEEJ Technical Meeting*, PSE-10-002, Fukui, Japan, Jan. 2009.
- [5] H. Bevrani, A. G. Tikdari, "An ANN-based Power System Emergency Control Scheme in the Presence of High Wind Power Penetration", Book chapter of *Wind Power Systems: Applications of Computational Intelligence*, L. F. Wang, C. Singh, and A. Kusiak (Eds), Springer Book Series on Green Energy and Technology, Springer-Verlag, Heidelberg, expected in 2010.
- [6] H. Bevrani, G. Ledwich, J. J. Ford and Z. Y. Dong, "On Feasibility of regional Power System Emergency Control Plans," *Energy Conversion & Management*, vol. 49, no. 2, pp. 193-204, 2009.
- [7] H. Bevrani, G. Ledwich, Z. Y. Dong, and J. J. Ford, "Regional Frequency Response Analysis under Normal and Emergency Conditions," *Electric Power Systems Research*, vol. 79, pp. 837-845, 2009.
- [8] A. G. Tikdari, Load shedding in the presence of renewable energy sources, Master Thesis, University of Kurdistan, September 2009.
- [9] H. Bevrani, et al., "On the use of  $df/dt$  in power system emergency control" In *Proc. of IEEE Power Systems Conference & Exposition*, Seattle, Washington, USA, 2009.