

MODEL PREDICTIVE BASED LOAD FREQUENCY CONTROL DESIGN

T. H. Mohamed^{*}, A.A.Hassan, H. Bevrani, and T. Hiyama,

ABSTRACT- In this paper, A new load frequency control (LFC) using the model predictive control MPC technique is presented. The MPC technique has been designed such that the effect of the uncertainty due to governor and turbine parameters variation and load disturbance is reduced. A simplified frequency response model is introduced, and physical constraints of the governor and turbine are considered in this model. The model was employed in the MPC structure. Digital simulations for a single control area are provided to validate the effectiveness of the proposed scheme. The results show that, with the proposed MPC technique, the system performance has a good robustness in the face of uncertainties due to governor and turbine parameters variation and load disturbance. A performance comparison between the proposed controller and a conventional integral control scheme is carried out confirming the superiority of the proposed MPC technique.

Keywords: Load frequency control, integral control, model predictive control .

1. Introduction

Over the past decades, due to the fact that LFC constitutes an important function of power system operation where the main objective is to regulate the output power of each generator at prescribed levels while keeping the frequency fluctuations within pre-specified limits. Many control strategies have been proposed and investigated by several researchers for LFC design of power systems [2-14]. Robust adaptive control schemes have been developed in [2-7] to deal with changes in system parameters. Fuzzy logic controllers have been used in many reports for LFC design in a two area power system [9-10], with and without nonlinearities. The applications of artificial neural network, genetic algorithms, and optimal control to LFC have been reported in [11-14]. In their findings it is observed that the transient response is oscillatory and it seems some other elegant techniques are needed to achieve a desirable performance. On the other hand, the MPC appears to be an efficient strategy to control many applications in industry, it has many advantages such as very fast response, robustness against load disturbance and parameters uncertainty.

H. Bevrani is with Dept. of Electrical Engineering & Computer Science, Kumamoto University, Kumamoto, Japan. (e-mail: bevrani@st.cs.kumamoto-u.ac.jp)

T.Hiyama is with Dept. of Electrical Engineering & Computer Science, Kumamoto University, Kumamoto, Japan. (e-mail: hiyama@cs.kumamoto-u.ac.jp)

A.A.Hassan is with Dept. of Electrical Engineering, Minia university (e-mail: aahsn@yahoo.com)

^{*}T. H. Mohamed is with High Institute of Energy, South Valley University, Egypt (e-mail: tahrhie@yahoo.com)

Its straightforward design procedure is considered as a major advantage of the MPC. Given a model of the system, only an objective function incorporating the control objectives needs to be set up. Additional physical constraints can be easily dealt with by adding them as inequality constraints,

whereas soft constraints can be accounted for in the objective function using large penalties. Moreover, MPC adapts well to different physical setups and allows for a unified approach [15-16].

In this paper, the load frequency control for a single area power system has been developed based on the MPC technique. The MPC technique law produces its optimal output derived from a quadratic cost function minimization based on the dynamic model of the single area power system. The technique calculates the optimal control signal while respecting the given constraints over the output frequency deviation and the load change. The effects of the physical constraints such as generation rate constraint (GRC) and speed governor dead band [1] are considered. The power system with the proposed MPC technique has been tested through the effect of uncertainties due to governor and turbine parameters variation and load disturbance using computer simulation. A comparison has been made between the MPC and the traditional integral controller confirming the superiority of the proposed MPC technique. The simulation results proved that the proposed controller can be applied successfully to the application of power system load frequency control.

The rest of the paper is organized as follows: The description of the dynamics of the power system is given in section 2. General consideration about MPC and its cost function are presented in section 3. The implementation scheme of a single area power

system together with the MPC technique is described in section 4. Simulation results and general remarks are presented in section 5. Finally, the paper is concluded in section 6.

2. System Dynamics

In this section, a simplified frequency response model for a single area power system with an aggregated generator unit is described [1].

The overall generator-load dynamic relationship between the incremental mismatch power ($\Delta P_m - \Delta P_L$) and the frequency deviation (Δf) can be expressed as:

$$s \cdot \Delta f = \left(\frac{1}{2H}\right) \cdot \Delta P_m - \left(\frac{1}{2H}\right) \cdot \Delta P_L - \left(\frac{D}{2H}\right) \quad (1)$$

the dynamic of the governor can be expressed as:

$$s \cdot \Delta P_m = \left(\frac{1}{T_t}\right) \cdot \Delta P_g - \left(\frac{1}{T_t}\right) \cdot \Delta P_m \quad (2)$$

the dynamic of the turbine can be expressed as:

$$s \cdot \Delta P_g = \left(\frac{1}{T_g}\right) \cdot \Delta P_c - \left(\frac{1}{R \cdot T_g}\right) \cdot \Delta f - \left(\frac{1}{T_g}\right) \cdot \Delta P_g \quad (3)$$

the block diagrams of the past equations are included in figure. 1.

equations (1), (2), and (3) represent a simplified frequency response model for one generator unit and can be combined in the following state space model:

$$\begin{bmatrix} s \cdot \Delta P_g \\ s \cdot \Delta P_m \\ s \cdot \Delta f \end{bmatrix} = \begin{bmatrix} -\frac{1}{T_g} & 0 & -\frac{1}{R \cdot T_g} \\ \frac{1}{T_t} & -\frac{1}{T_t} & 0 \\ 0 & \frac{1}{2H} & -\frac{D}{2H} \end{bmatrix} \begin{bmatrix} \Delta P_g \\ \Delta P_m \\ \Delta f \end{bmatrix} + \begin{bmatrix} 0 \\ 0 \\ -\frac{1}{2H} \end{bmatrix} \Delta P_L + \begin{bmatrix} \frac{1}{T_g} \\ 0 \\ 0 \end{bmatrix} \Delta P_c \quad (4)$$

$$y = \begin{bmatrix} 0 & 0 & 1 \end{bmatrix} \begin{bmatrix} \Delta P_g \\ \Delta P_m \\ \Delta f \end{bmatrix} \quad (5)$$

Where:

- s : differential operator.
- ΔP_g : the governor output change.
- ΔP_m : the mechanical power change
- Δf : the frequency deviation,
- ΔP_L : the load change
- ΔP_c : supplementary control action
- y : the system output.
- H : equivalent inertia constant
- D : equivalent damping coefficient
- R : speed droop characteristic
- T_g and T_t : are governor and turbine time constants.

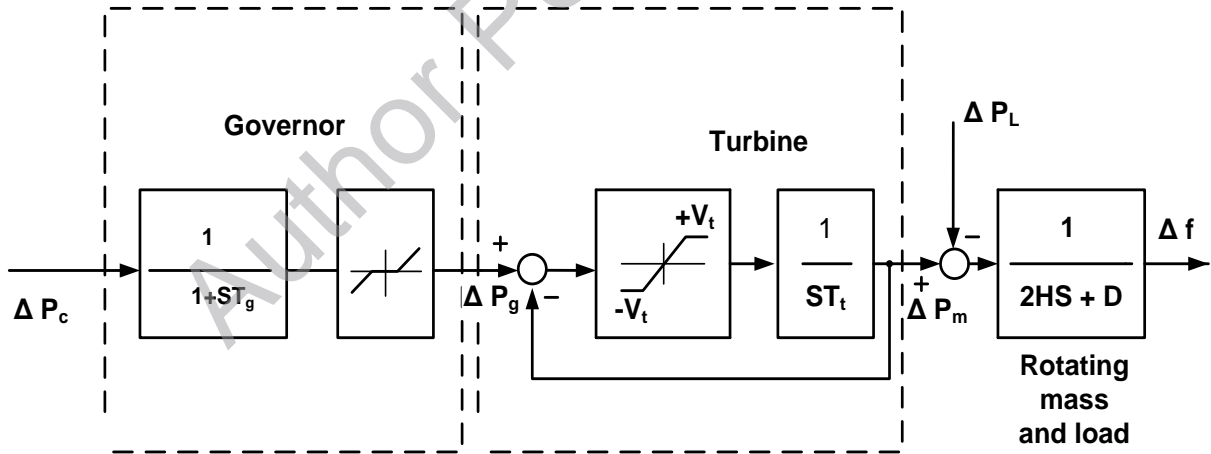

Fig. 1 The block diagram of uncontrolled single area power system

3. Model Predictive Control

The MPC has proved to efficiently control a wide range of applications in industry such as chemical process, petrol industry, electromechanical systems and many other applications. The MPC scheme is based on an explicit use of a prediction model of the system response to obtain the control actions by minimizing an objective function. Optimization objectives include minimization of the difference between the predicted and reference response, and the control effort subjected to prescribed constraints. The effectiveness of the MPC is demonstrated to be equivalent to the optimal control. It displays its main strength in its computational expediency, real-time applications, intrinsic compensation for time delays, treatment of constraints, and potential for future extensions of the methodology. At each control interval, the first input in the optimal sequence is sent into the plant, and the entire calculation is repeated at subsequent control intervals. The purpose of taking new measurements at each time step is to compensate for unmeasured disturbances and model inaccuracy, both of which cause the system output to be different from the one predicted by the model [15-16].

Figure 2 shows a simple structure of the MPC controller. An internal model is used to predict the future plant outputs based on the past and current values of the inputs and outputs and on the proposed optimal future control actions. the prediction has two main components : the free response which being expected behavior of the output assuming zero future control actions, and the forced response which being the additional component of the output response due to the candidate set of future controls. For a linear systems, the total prediction can be calculated by summing both of free and forced responses, reference trajectory signal is the target values the output should attain. The optimizer is used to calculate the best set of future control action by minimizing a cost function (J), the optimization is subject to constraints on both manipulated and controlled variables [17].

The general object is to tighten the future output error to zero, with minimum input effort. The cost function to be minimized is generally a weighted sum of square predicted errors and square future control values, e.g. in the Generalized Predictive Control (GPC) :

$$J(N_1, N_2, N_u) = \sum_{j=N_1}^{N_2} \beta(j) [\hat{y}(k+j|k) - w(k+j)]^2 + \sum_{j=1}^{N_u} \lambda_j u(k+j-1)^2 \quad (6)$$

Where N_1, N_2 are the lower and upper prediction horizons over the output, N_u is the control horizon, $\beta(j), \lambda(j)$ are weighting factors. The control horizon permits to decrease the number of calculated future control according to the relation: $\Delta u(k+j) = 0$ for $j \geq N_u$.

$w(k+j)$ represents the reference trajectory over the future horizon N .

Constraints over the control signal, the outputs and the control signal changing can be added to the cost function as follows:

$$\begin{aligned} u_{min} &\leq u(k) \leq u_{max} \\ \Delta u_{min} &\leq \Delta u(k) \leq \Delta u_{max} \\ y_{min} &\leq y(k) \leq y_{max} \end{aligned} \quad (7)$$

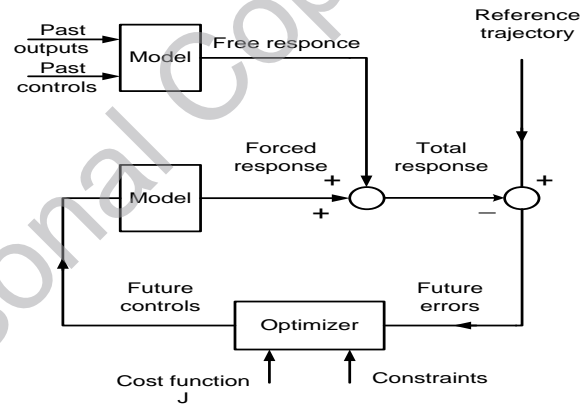

Fig. 2 A simple structure of the MPC controller

Solution of equation (6) gives the optimal sequence of control signal over the horizon N while respecting the given constraints of equation (7).

Model Predictive Control have many advantages, in particularly it can pilot a big variety of process, being simple to apply in the case of multivariable system, can compensate the effect of pure delay by the prediction, inducing the anticipate effect in closed loop, being a simple technique of control to be applied and also offer optimal solution while respecting the given constraints. On the other hand, this type of restructure required the knowledge of model for the system, and in the present of constraints it becomes a relatively more complex regulator than a simple conventional controller such as a PID for example, and it takes more time for on-line calculations

4. System configuration

The block diagram of a simplified frequency response model for a single area power system with aggregated unit including the proposed MPC controller is shown in Fig. 3.

The system consists of the rotating mass and load, nonlinear turbine with GRC, and governor with dead-band constraint [1]. On the other hand, the frequency deviation is used as feedback for the closed loop control system. The measured and reference frequency deviation Δf , ($\Delta f_{ref} = 0$ Hz) are fed to the model predictive controller in order to obtain the supplementary control action ΔP_c which add to the negative frequency feedback signal. The resulting signal ΔP_s is fed the governor giving the governor valve position which supplies the turbine to give the mechanical power change ΔP_m which is affected by the load change ΔP_L giving the input of the rotating mass and load block to provide actual frequency deviation Δf .

5. Results and Discussions

Computer simulations have been carried out in order to validate the effectiveness of the proposed scheme. The Matlab/Simulink software package has been used for this purpose. A practical single area power system having the following nominal parameters [1] listed in table I.

The simulation studies are carried out for the proposed controller with generation rate constraint (GRC) of 10% p.u. per minute. The maximum value of dead band for governor is specified as 0.05%. The parameters of the MPC controller are set as follows: Prediction horizon = 10, control horizon = 2, Weights on manipulated variables = 0, Weights on manipulated variable rates = 0.1, Weights on the output signals = 1, Sampling interval = 0.0003 sec. Constraints are imposed over the control action, and frequency deviation are considered as follows : Max. control action = 0.25 pu. Min. control action = -0.25 pu. Max. frequency deviation = 0.25 pu. Min. frequency deviation = -0.25 pu.

Firstly, the system performance with the proposed MPC controller at nominal parameter is tested and compared with the system performance with a conventional integrator ($K_I = -0.03$). Figure. 4 shows the simulation results in this case. The results from the top to the bottom are: the governor valve position ΔP_m of both proposed MPC and conventional integrator systems, the frequency deviations and the governor's controlled input signals of both two systems following a step load change (the ΔP_L assumed to be 0.02 pu at $t = 3$ SEC.). It has been noticed that with the proposed MPC controller the system is more stable and fast comparing with the system with traditional integrator.

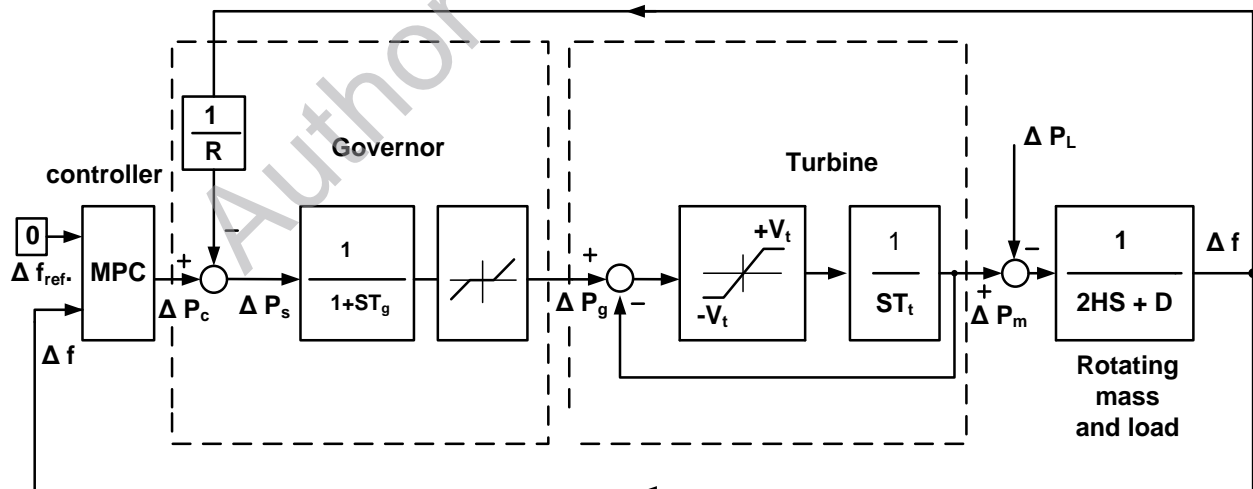

Fig. 3 The block diagram of a single area power system including the proposed MPC controller

Table I Parameters and data of a practical single area power system.

D(p/Hz)	H(pu.sec)	R(Hz/pu)	T_g (sec)	T_t (sec)
0.015	0.08335	3.00	0.08	0.4

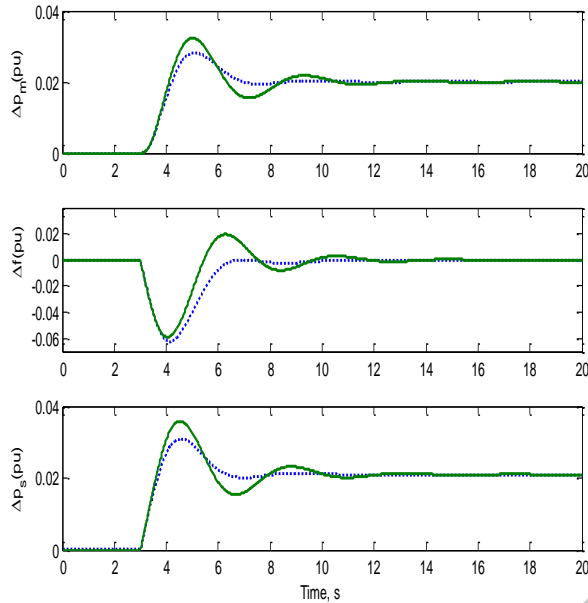

Fig. 4 Power system responses to the first case a) the governor valve position ΔP_m , b) the frequency deviation Δf , and c) the governor's control signal ΔP_s .

Secondly, the system is tested at high load change (the ΔP_L assumed to be 0.06 pu at $t = 3$ sec.), Figure 5 shows the result of the MPC response as well as of the conventional integral responses in this case, again, MPC response is much faster and more stable than that of traditional integral responses and able to deal with load changes more efficiently.

finally, the robustness of the proposed MPC controller against parameter uncertainty is validated. In this case, both of the governor and turbine time constants are increased to $T_g = 0.12$ sec and $T_t = 0.95$ sec., respectively. Figure 6 depicts the response of the

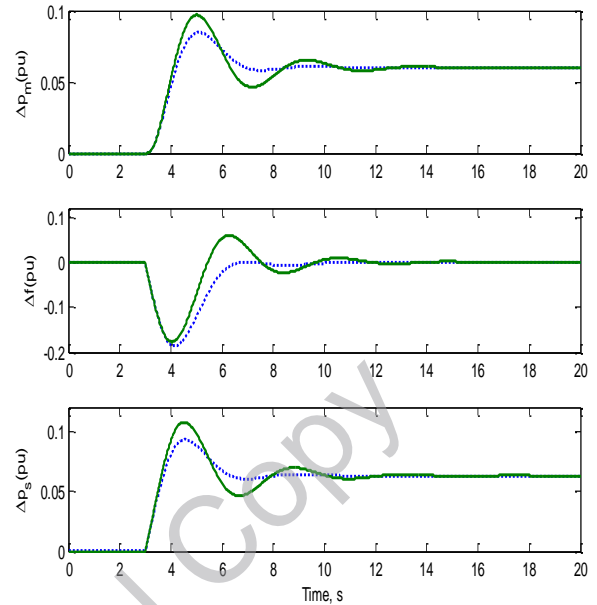

Fig. 5 Power system responses to the second case a) the governor valve position ΔP_m , b) the frequency deviation Δf , and c) the governor's control signal ΔP_s .

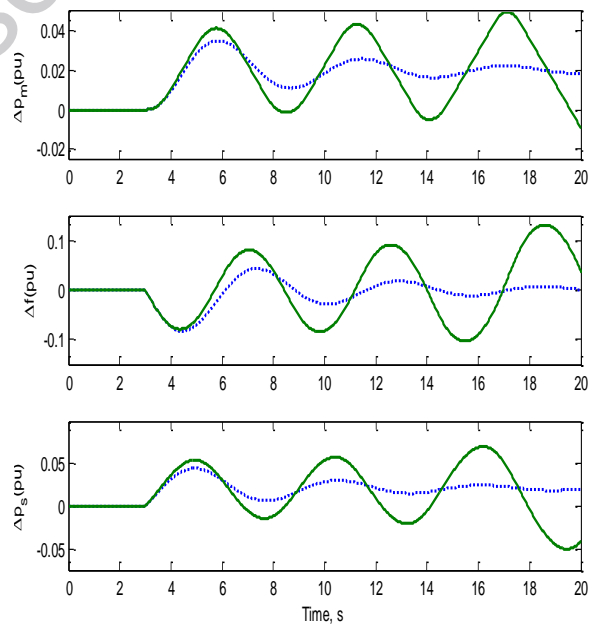

Fig. 6 Power system responses to the last case a) the governor valve position ΔP_m , b) the frequency deviation Δf , and c) the governor's control signal ΔP_s .

MPC controller in this case of uncertainty at same load change described in the first case. It has been indicated that a desirable performance response has been achieved using the MPC controller while with conventional integrator, unstable response has been achieved.

6. Conclusion

This paper investigates robust load frequency control of a single area power system based on the model predictive control technique. Digital simulations have been carried out in order to validate the effectiveness of the proposed scheme. The proposed controller has been tested for several mismatched parameters and load disturbance.

Simulation results show that the fast response, robustness against parameter uncertainties and load changes can be considered as some advantages of the proposed MPC controller. In addition, a performance comparison between the proposed controller and a conventional integrator control scheme is carried out. It is shown that the MPC controller response is much better than that of traditional integrator response and able to deal with both of parameter uncertainty and load changes more efficiently.

References

- [1] H. Bevrani, "Robust Power system control", Springer, New York, pp. 15-61, 2009.
- [2] Lim, K. Y., Wang, Y. and Zhou, R., "Robust Decentralized load-frequency control of multi-area power systems" IEE Proc. Gener., Transm. Distrib., Vol. 143, No. 5, pp. 377-386, 1996.
- [3] Wang, Y., Hill, D. J. and Guo, G., "Robust Decentralized Control for Multimachine Power System", IEEE Transactions on circuits and systems: Fundamental Theory and Applications, Vol. 45, No. 3, 1998.
- [4] Stankovic, A. M., Tadmor, G. and Sakharuk, T. A., "On robust control analysis and design for load frequency regulation", IEEE Trans. on Power Systems, Vol. 13, No. 2, pp. 449-455, 1998.
- [5] Pan, C. T. and Liaw, C. M., "An adaptive controller for power system load-frequency control", IEEE Trans. on Power Systems, Vol. 4, No. 1, pp. 122-128, 1989.
- [6] Muthana T. Alrifai and Mohamed Zrib, "Decentralized Controllers for Power System Load Frequency Control", ASCE Journal, Volume (5), Issue (II), June, 2005.
- [7] H. Bevrani, Y. Mitani and K. Tsuji, "Robust AGC: Traditional structure versus restructured scheme", Trans. of Electrical Engineering in Japan, Vol. 124-B, No. 5, May 2004.
- [8] HO Jae Lee, Jin Bae Park, Young Hoon Joo, "Robust LFC for Uncertain nonlinear power systems: A fuzzy logic approach", Information Science 176 (2006), pp: 3520 –3537.
- [9] cam E, Kocaarslan I, "Load frequency control in two area power systems using fuzzy logic controller" Energy conversion management 46 (2005), pp: 233 – 243.
- [10] Birch, A. P., Sapeluk, A. T. and Ozveren, C. S., "An enhanced neural network load frequency control technique", Control 94, 21-24 March 1994, Conference Publication No. 389, IEE 1994. ASCE Journal, Volume (5), Issue (II), June, 2005
- [11] Abdel-Magid, Y. L. and Dawoud, M. M., "Genetic Algorithms Applications In Load Frequency Control", Genetic algorithms in engineering systems: innovations and applications , 12-14 September 1995, conference publications No. 414, IEE, 1995.
- [12] Rerkpreedapong, D., Hasanovic, A. and Feliachi, A., "Robust load frequency control using genetic algorithms and linear matrix inequalities", IEEE Transactions on Power Systems, Vol. 18, No. 2, pp. 855 -861, 2003.
- [13] Demiroren, A., Zeynelgil, H. L. and Sengor, N. S., "The Application of ANN technique to Load-Frequency Control for Three-area Power system", Paper accepted for presentation at PPT 2001, 2001 IEEE Porto Power Tech conference 10th-13th September, Porto, Portugal.
- [14] Liu, F., Song, Y.H., Ma, J., Mai, S. and Lu, Q., "Optimal load-frequency control in restructured power systems", IEE Proceedings- Generation, Transmission and Distribution, Vol. 150, No. 1, pp. 87-95, 2003
- [15] Thomas J., D. Dumur, J. Buisson and H. Gueguen, "Model Predictive Control for Hybrid Systems under a State Partition based MLD Approach (SPMLD)". International conference on informatics in control, automation and robotics ICINCO'04, Vol. 3, pp. 78-85, Setúbal, 2004.
- [16] Richalet J., A. Rault, J. L. Testud and J. Japon, "Model predictive heuristic control", application to industrial processes. Automatica, 14(5), pp. 413-428, 1978.
- [17] Clarence W. De Silva "Mechatronic systems : devices, design, control, operation and monitoring", book, Taylor and Francis Group, LLC, 2008.