



Aalborg Universitet

AALBORG UNIVERSITY
DENMARK

A Novel Robust Communication Algorithm for Distributed Secondary Control of Islanded MicroGrids

Shafiee, Qobad; Dragicevic, Tomislav; Quintero, Juan Carlos Vasquez; Guerrero, Josep M.; Stefanovic, Cedomir; Popovski, Petar

Published in:

Proceedings of the IEEE Energy Conversion Congress and Exposition, ECCE 2013

DOI (link to publication from Publisher):

[10.1109/ECCE.2013.6647318](https://doi.org/10.1109/ECCE.2013.6647318)

Publication date:

2013

Document Version

Early version, also known as pre-print

[Link to publication from Aalborg University](#)

Citation for published version (APA):

Shafiee, Q., Dragicevic, T., Vasquez, J. C., Guerrero, J. M., Stefanovic, C., & Popovski, P. (2013). A Novel Robust Communication Algorithm for Distributed Secondary Control of Islanded MicroGrids. In Proceedings of the IEEE Energy Conversion Congress and Exposition, ECCE 2013. (pp. 4609-4616). IEEE Press.
10.1109/ECCE.2013.6647318

General rights

Copyright and moral rights for the publications made accessible in the public portal are retained by the authors and/or other copyright owners and it is a condition of accessing publications that users recognise and abide by the legal requirements associated with these rights.

- ? Users may download and print one copy of any publication from the public portal for the purpose of private study or research.
- ? You may not further distribute the material or use it for any profit-making activity or commercial gain
- ? You may freely distribute the URL identifying the publication in the public portal ?

Take down policy

If you believe that this document breaches copyright please contact us at vbn@aub.aau.dk providing details, and we will remove access to the work immediately and investigate your claim.

A Novel Robust Communication Algorithm for Distributed Secondary Control of Islanded MicroGrids

Qobad Shafiee, Tomislav Dragicevic,
Juan C. Vasquez, and Josep M. Guerrero
Institute of Energy Technology
Aalborg University (AAU)
Aalborg East DK-9220, Denmark

Cedomir Stefanovic
and Petar Popovski
Department of Electronic Systems
Aalborg University (AAU)
Aalborg East DK-9220, Denmark

Abstract—Distributed secondary control (DSC) is a new approach for MicroGrids (MGs) such that frequency, voltage and power regulation is made in each unit locally to avoid using a central controller. Due to the constrained traffic pattern required by the secondary control, it is viable to implement dedicated local area communication functionality among the local controllers. This paper presents a new, wireless-based robust communication algorithm for DSC of MGs designed to avoid communication bottlenecks and enable the plug-and-play capability of new DGs. Real-time simulation and experimental results are presented to evaluate the feasibility and robustness endowed by the proposed algorithm.

I. INTRODUCTION

A microgrid is defined as a localized cluster of distributed generators (DGs) and loads, placed in low voltage (LV) and medium voltage (MV) distribution networks, which can operate autonomously in islanded mode or connected to the main grid [1], [2]. These local grids encompass several technology components: power electronics, control, as well as communication/information technology. The ideas supporting the formation of the MGs are 1) reducing transmission/distribution losses and preventing electrical network congestion by shifting the generation closer to the consumers/loads; 2) gradually reducing the chance of blackouts, as MGs can operate in islanded mode during system disturbances and faults; 3) enhancing the reliability of the system, as the chance of losing significant amounts of generation at a time is diminished; and 4) provision of ancillary services to the main grid in the grid-connected mode.

However, apart from these obvious benefits of MGs, their introduction into the traditional distribution network raises many new challenges, with one of the most important being frequency and voltage participation in islanded operation mode. This problem has been in the focus of many recent works [1]–[10]. To that end a hierarchical control concept from the traditional power system has been introduced for MGs in [1]. The first level of this hierarchy is *primary control* which deals with the inner voltage and current control loops and droop control of the individual DGs in order to adjust the frequency and amplitude according to active and reactive

power of the units. As the primary level is strictly local, without communications with other units, it is not able to regulate frequency and voltage of the system when MG is perturbed by either load variations or connection/disconnection of the units. Then, the *secondary control* is often employed in order to remove the frequency and voltage deviations in steady state and to achieve a global controllability of the MG. Furthermore, the secondary control may share power between units of the MG in cases when primary control is unable to do it [11]–[13]. The *tertiary control* is responsible for global optimization of the MG and managing power flow between MGs and distribution network of the main grid [14], [15]. Usually, the primary and the tertiary control levels are decentralized and centralized control levels, respectively, while the secondary control can be implemented in both centralized and decentralized way [12].

In centralized secondary control (CSC), all DGs measure signals of interest and send them to a common single MG central controller (MGCC), which in turn produces appropriate control signals based on the received data and forwards it to the local primary control of the DGs [1], [2], [8], [10]. The exchange of measurements and control signals requires an underlying communication network. Although straightforward to implement, the centralized control strategy has an inherent drawback of the single point of failure, i.e., a MGCC failure terminates the secondary control action for all units [1].

Distributed secondary control strategy is a new approach [12] that avoids use of a single centralized controller for secondary level of MGs. In this architecture, the primary and secondary controllers are implemented together locally in each DG, where the secondary control should collect the required data from all other units and produce appropriate control signal for the primary one using an averaging method. Data exchange for DSC can be implemented in several ways, ranging from simple all-to-all transmissions [12] to more involved schemes based on distributed consensus algorithms [16]. The former approach is conceptually simple, but does not scale, as the number of required data exchanges grows quadratically with the number of DGs. Distributed consensus

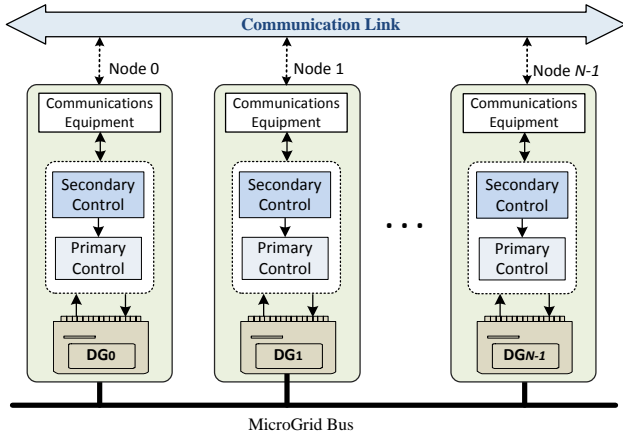

Fig. 1. A scheme illustrating the general architecture of distributed secondary control for islanded MGs.

relies on a series of local data exchanges among neighboring units to achieve global information dissemination; its use for information dissemination in MGs has been proposed recently in [17]–[19]. In this paper we present a simple networked control scheme for the distributed secondary control of MGs which exploits the broadcast nature of the wireless medium. The proposed scheme is discrete-time and operates in rounds. In each round, a non-transmitting DG attempts to receive the broadcast packet, then update its local record on the averages of the parameters and derives the local control signal accordingly. The broadcasts are performed by units in a round robin manner, representing a current record of the respective unit averages. Even though the proposed scheme is conceptually similar to the schemes that exploit distributed consensus [17]–[19], the major difference is that the communications and control layers are not separated, but the scheme exploits their inherent feedback loop. Specifically, rather than waiting for a series of local data exchanges to converge to the global average at every DG, in the proposed approach the control signal is locally updated after each data exchange, enforcing the MG towards the desired operation point. We show that the proposed scheme enhances reliability of distributed secondary control, making it robust against delays and packet losses in the wide range of wireless link conditions. Also, the proposed scheme is designed not only for regulation of frequency and voltage but also for power sharing among the units, maintaining the power sharing feature of the primary droop controller.

The paper is organized as follows. Distributed secondary control of islanded MGs is presented in Section II. In Section III the proposed communication algorithm for DSC is elaborated. Section IV provides simulation results of an islanded MG with four units, evaluating the proposed algorithm for DSC. An experimental validation of the proposed solution in an islanded MG with two units is presented in Section V. Section VI concludes the paper and outlines future research directions.

II. DISTRIBUTED SECONDARY CONTROL OF ISLANDED MICROGRIDS

A distributed control strategy is an approach in which none of the controllers are centralized, but distributed throughout the system so that each unit is controlled independently and the entire system of controllers is connected by a communication network. Fig. 1 illustrates the implementation of the distributed control strategy. As shown, the secondary control is locally embedded in each DG unit, similar to the primary control; however, the local secondary control requires an underlying communication network to operate properly. The combined communication-control algorithm, presented in the Section III, is used to exchange and update averages of the parameters of interest to secondary controllers. In turn, the local secondary controllers operate on these parameters, regulating frequency and voltage of the system and sharing power between the units.

Conventional CSC is only responsible for restoring frequency and voltage inside the whole MG using common measurements of the system [1], [10]. However, DSC using the proposed communication algorithm is able not only to control frequency and voltage but also to share power between units in the MG. We continue by elaborating the used DSC algorithm in details, and note that, henceforth, we assume that the MG consists of N DG units, denoted as $DG_0, DG_1, \dots, DG_{N-1}$.

A. Frequency and Voltage Control

Load frequency control is the central secondary control for frequency regulation in large power systems, as frequency is a control variable that provides information related to the consumption/generation balance of the grid [20]. Taking the idea from large power systems, a centralized secondary control is implemented in the MG in order to regulate the frequency of the whole system. However, in the distributed strategy, each DG has its own local secondary control to regulate the frequency. In this sense, each unit measures its frequency at each sampling instant, averaging the received information from other units and then broadcasting its average version (\bar{f}_{MG}) to the other units through the communication network. The averaged data is compared to the nominal frequency of MG (f_{MG}^*), and sent to the secondary controller of DG_i to restore the frequency as follows:

$$\delta f_i = k_{pf} (f_{MG}^* - \bar{f}_{MG}) + k_{if} \int (f_{MG}^* - \bar{f}_{MG}) dt, \quad (1)$$

where k_{pf} and k_{if} are the control parameters of the PI compensator of unit i , and δf_i is the secondary control signal sent to the primary control level in order to remove the frequency deviations.

Since the Q-V droop control is not able to regulate the voltage in the MG, a controller similar to the one controlling frequency can be implemented in secondary control level for voltage restoration [1], [10]. In this secondary voltage control strategy, after calculating the average value of voltage \bar{E}_{MG} that is based on the information exchanged over communication network, every local secondary controller measures the voltage error and compares it with the voltage reference of

MG, E_{MG}^* . In the next step, the local secondary controller sends the control signal δE_i to the primary level of control as a set point to compensate the voltage deviation. The voltage restoration control loop of DG_i can be expressed as follows:

$$\delta E_i = k_{pE} (E_{MG}^* - \bar{E}_{MG}) + k_{iE} \int (E_{MG}^* - \bar{E}_{MG}) dt, \quad (2)$$

with k_{pE} and k_{iE} being the *PI* controller parameters of the voltage secondary control. The above secondary control strategy can be also extended to more resistive line MGs that are using P-V and Q-f droops in the primary control, to regulate frequency and voltage. Consequently, the secondary control is applicable to the all resistive/inductive (R/X) nature of the power lines, as opposed to the primary control.

B. Power Sharing

In a low R/X MG, reactive power is difficult to be precisely shared between units using Q-V droop control, since voltage is not common in the whole system as opposed to the frequency. Furthermore, the impedance between the DG units and the point of common coupling is not necessarily the same; similar effect occurs when trying to equalize active power of units using P-V in high resistive line MGs.

An alternative solution is to implement a distributed average power sharing in the secondary loop, where the averaging is performed through communication network. In this way, all units obtain the same reference and power sharing is achieved independently from voltage sensing mismatches or line impedances in the MG. The distributed averaged power sharing by the secondary control of DG_i can be expressed as follows:

$$\delta P_i = k_{pP} (P_i - \bar{P}_{MG}) + k_{iP} \int (P_i - \bar{P}_{MG}) dt, \quad (3)$$

where k_{pP} and k_{iP} are the *PI* controller parameters, P_i is the locally calculated power (active power in the case of high resistive line MGs, or reactive power in the case of high inductive line MGs), \bar{P}_{MG} is the average power obtained through communication network, and δP_i is the control signal produced by the secondary control in each sample instant, and afterwards sent to the primary loop.

It is worth noting that anti-windup saturation blocks are implemented for every *PI* controller of secondary control in order to protect the units in case of extreme contingencies. A detailed block diagram of the DSC strategy for an individual DG (DG_i) in an islanded power electronic-based MG is shown in Fig. 2; the figure shows a general scheme of the primary control as well. Interested readers can find more detail about the primary control in [10].

III. THE PROPOSED BROADCAST ALGORITHM

We assume that all units are in communication range of each other, such that connection is maintained between each pair of units, but allowing random packet losses between the units. Communication occurs in discrete, periodic time instants and all units are assumed to be synchronized to that periodic

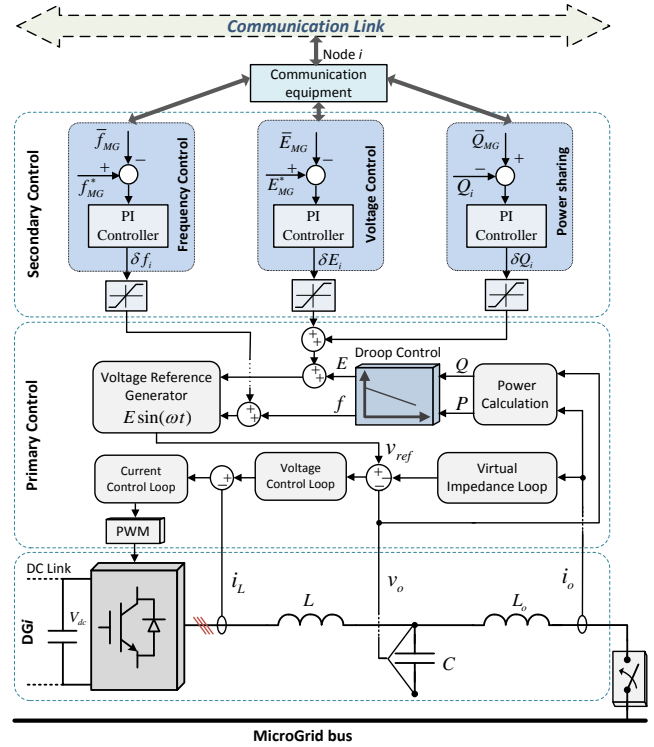

Fig. 2. Details of the proposed DSC for an individual DG in an islanded MG.

communication structure. Note that this synchronization requires packet-level precision, not symbol level, which makes it very practical. At each time instant k , every unit measures the parameters of interest, i.e., frequency, voltage and power.

In the following text, we present the algorithm for the distributed averaging of a general parameter x , which can stand for frequency, voltage, or power. The measurement of x made by DG_i in at the k -th time instant is denoted by $x_i(k)$. The current local estimate of the global average a of parameter x that is computed by DG_i in instant k is denoted by $a_i(k)$. At the k -th time instant the unit that is allowed to broadcast is DG_j , where $j = k \bmod N$. Such a rule implements a round robin broadcasting scheme among the N DGs. The signal broadcasted at the k -th time instant can be written as:

$$b(k) = a_j(k) \text{ where } j = k \bmod N \quad (4)$$

The local estimates $\{a_i(k)\}$ of all DGs, including the broadcasting one, are updated in the following way:

$$a_i(k) = \beta_i x_i(k) + (1 - \beta_i) b_i(k), \quad i = 0, 1, \dots, N - 1. \quad (5)$$

where $b_i(k)$ is the local record of the received broadcast signal:

$$b_i(k) = b(l_i), \quad l_i < k, \quad (6)$$

and l_i denotes the time instant at which the last successful broadcast has been received by agent DG_i . In case when there are no packet losses $b_i(k) = b(k - 1)$, $i = 0, 1, \dots, N - 1$. Finally, β_i is suitably chosen constant that determines the weight of the measurement made by DG_i when computing

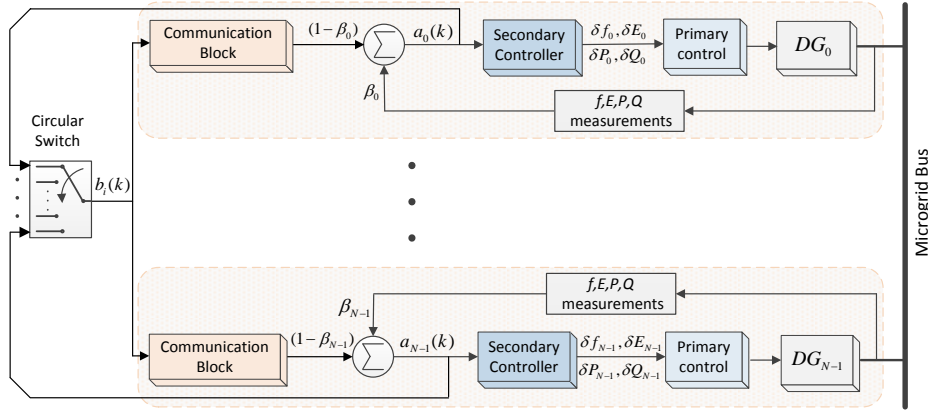

Fig. 3. Implementation of proposed algorithm on DSC of an islanded MG.

the estimate; a straightforward choice is to set $\beta_i = 1/N$, $i = 0, 1, \dots, N - 1$.

The algorithm can be interpreted as if the units use broadcast to exchange the local estimates of the global average. As these estimates contain the locally measured values, the broadcasts actually exchange the information necessary for the computation of the global average. As time progresses, the “mixing” of the local measurements in every agent becomes more effective, and the units start converging toward the same global average value. The locally executed DSC algorithm operates on the local estimates, such that control signals shifts the local parameter $x_i(k)$ towards the computed local estimate $a_i(k)$ of the global average a , $i = 0, 1, \dots, N$; this feedback between the control algorithm and the update rule accelerates the local convergence towards the global average. The convergence speed towards the global average depends on the relation between, on one hand, the rate by which a changes and, on the other hand, the rate of information exchange i. e., how often broadcasts are performed. The rate of information exchange primarily depends on the characteristics of the employed communication technology. In a typical MG setup, the wireless propagation delays can be neglected and the dominant component of the communication delay is the processing performed by the protocol stack. This consists of: reception of the broadcast packet, update of the local estimate and the transmission of the update. As an example, we have performed an experimental study that showed that the minimum expected delay in IEEE 802.11 (WiFi) from the moment of packet reception until the broadcasting has completed is of the order of 10 ms, implying that the update information in the network can be exchanged roughly at the rate of 100 Hz, i.e., 100 times in a second. Nevertheless, this rate is rather adequate for DSC, since, in contrast to the primary control, the secondary and tertiary controllers in MGs typically operate with low sampling rates [1]. We note that a rigorous proof of the convergence would have to include a analytical model of the primary control, secondary control, communication network, the proposed algorithm for information exchange and update, as well as their interdependencies, and, as such, represents a rather complex problem in its own right and is

outside the scope of this paper. In Sections IV and V we demonstrate the potential of the proposed networked control solution in simulation and laboratory setups, respectively, while the analytical modeling is part of our on-going work.

The proposed scheme requires synchronization among DGs, which can be achieved in several ways in practice. For instance, synchronization could be implemented using suitable distributed synchronization protocols [21]. Another, highly reliable approach is to equip all DGs with GPS receivers that supply very accurate time reference. Finally, distributed scheduling of broadcast transmissions can be achieved using algorithms such as the ones described in [22]; the details are out of the scope of the paper.

We conclude this section by displaying a block-diagram that represents the proposed networked control system, given in Fig. 3. As shown, DGs are interconnected through the power and communication network, and each DG implements the same primary control, as well as the combined communication/secondary control. We note that the circular switch only models the operation of the round-robin scheduling algorithm, which is actually implemented in a distributed way across the network nodes.

IV. POWER HARDWARE-IN-THE-LOOP SIMULATION RESULTS

In order to evaluate the effectiveness of the proposed algorithm for DSC, an islanded low R/X MG consisting of four DGs is considered as a case study, shown in Fig. 4. All units in the system have the same power rate of 2.2 kW and each one is supporting a local load; units 1 to 4 feed 200 Ω , 400 Ω , 200 Ω , and 400 Ω resistive loads, respectively. The electrical part of system has been implemented in Matlab SimPower Systems[®] and the control part in Matlab Simulink[®]. The dSPACE[®] 1103 is a real time platform used as an interface between the electrical part and control part to produce a power hardware-in-the loop (PHIL) simulation. The proposed communication algorithm has been implemented in Matlab Stateflow[®], which provides graphical interface for modeling sequential decision and temporal logic flow charts and is fully

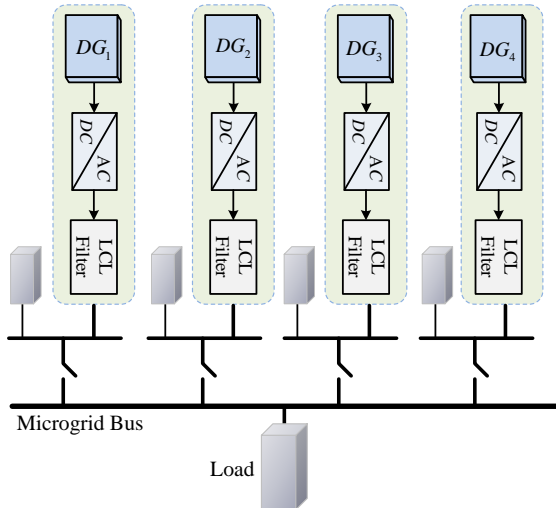

Fig. 4. Simulation case study: an islanded microgrid with four units.

compatible with dSPACE[®] 1103. The electrical setup and control system parameters are detailed in Table IV.

All the simulation results have been extracted from dSPACE control desk[®] but plotted using MATLAB[®]. Fig. 5 shows simulation results for different scenarios evaluating the performance of the proposed DSC. Fig. 5(a) shows restoration of the frequency to its nominal value. Specifically, during the first five seconds of operation, where the MG is under only the primary P-f droop controller, a steady-state frequency deviation from nominal value exists. In order to remove the deviation, the proposed DSC is implemented at $t = 5$ s, and, as it can be observed, the system frequency is successfully regulated. Performance of the proposed DSC in the presence of frequent load changes is evaluated in the latter half of the simulation where a 200Ω load was connected for a short time and then disconnected, at $t = 17$ s and $t = 27$ s, respectively. As it can be observed, the DSC using the proposed algorithm is able to quickly regulate the MG frequency despite these rapid load variations. Fig. 5(c) shows the corresponding active power injections to four units in the same scenarios, illustrating that the primary P-f droop method is sufficient to share the active power accurately between the units, and that the DSC preserves the power sharing properties established by the primary controller. Since the load is resistive, a considerable increase in active power is observed in the second half of the simulation when the DSC tries to remove the steady state frequency deviations. It is worth mentioning that for units with different power rate, the DSC may consider different coefficients for its output signals.

Fig. 5(b) depicts how the proposed DSC regulates voltage amplitude inside the MG. Similar to P-f droop control frequency deviations, Q-V droop control also produces substantial voltage deviations, as seen in the first five seconds of simulation. When the DSC is enabled at $t = 5$ s, the voltage is well restored, removing the static deviation produced by the droop control. The figure illustrates that the DSC has also a good performance when rejecting voltage disturbances caused

TABLE I
ELECTRICAL SETUP AND CONTROL SYSTEM PARAMETERS

Parameter	Symbol	Value
Electrical parameters		
Nominal voltage	E	311 V
Nominal frequency	$f^*/2\pi$	50 Hz
DC Voltage	V_{dc}	650 V
Output inductance	L_o	1.8 mH
Filter inductance	L	1.8 mH
Filter capacitance	L	$25 \mu F$
Load	$R_L(t)$	200,400 Ω
dSPACE sampling frequency	f_s	10 kHz
Droop Control		
Integral droop P coefficient	m_i	0.00001 W/rd
Proportional droop P coefficient	m_p	0.0008 W/rd·s
Proportional amplitude droop	n_p	0.16 VAr/V
DSC		
Frequency proportional term	$k_p f$	0.001
Frequency Integral term	$k_i f$	$4 s^{-1}$
Voltage proportional term	$k_p E$	0.001
Voltage Integral term	$k_i E$	$0.6 s^{-1}$
Reactive power proportional term	$k_p Q$	0.00001 VAr/V
Reactive power integral term	$k_i Q$	0.3 VAr/Vs

by load variations. Fig. 5(d) represents the effectiveness of proposed secondary control strategy for sharing reactive power among all four units. It can be observed that the primary droop control alone is not able to equalize the reactive power of DGs in the MG. After implementing the DSC, reactive power is shared properly between DGs, even in the presence of load variations.

It is worth noting that the speed of secondary control can be enhanced by increasing the parameters of PI controllers of DSC. However, the speed increase is limited both by the communication network and the bandwidth of the primary control.

A. Effects of Packet Delay

So far, we have assumed that information exchanged via broadcasts represents the most recent state of the DGs. In this section we relax this condition and examine the effects of information delay, comprising the delay due to measurement, processing, transmission and reception of data. Specifically, the performance of the DSC was investigated for three different delays: 1 s, 2 s, and 10 s. For the sake of simplicity, only frequency and voltage responses are represented.

Fig. 6 illustrates how delay affects the system output, when the DSC tries to remove frequency and voltage deviations caused by frequent load variation. Fig. 6(a) and Fig. 6(b) respectively depict frequency and voltage response of the system to the frequent load switching when interval duration is set to 1 s. In the first half of the simulation a 200Ω load is connected to the MG and then in the second half disconnected again. As it can be observed, the proposed scheme exhibits an acceptable response with small overshoots. The second row of Fig. 6 shows robustness of the proposed method, as the MG system is still stable when the delay is 10 s - the DSC slowly

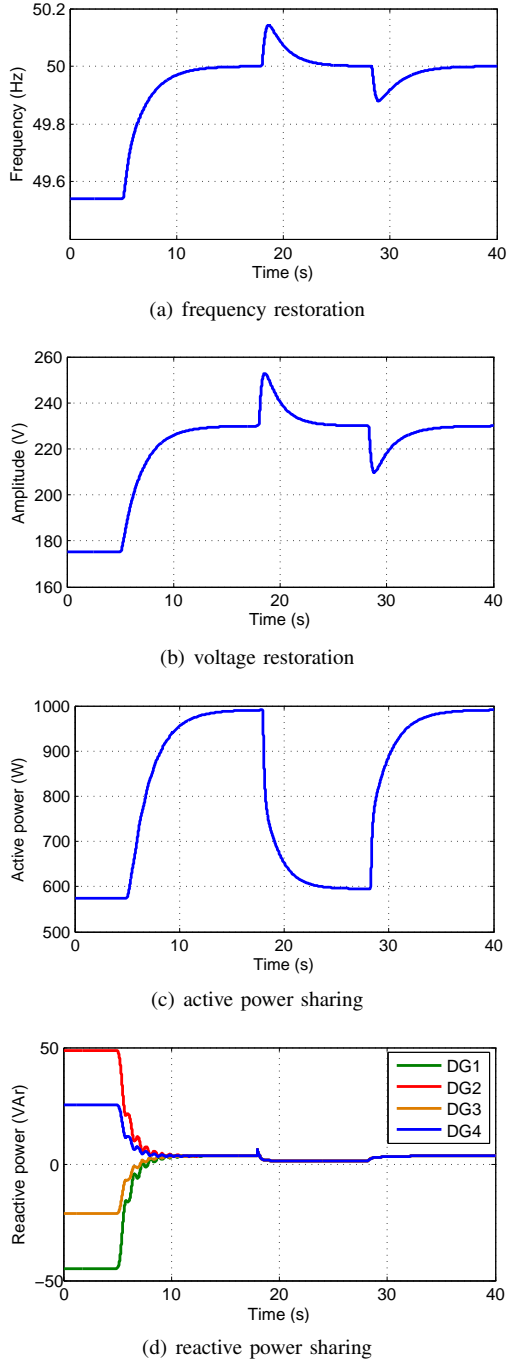

Fig. 5. Performance of DSC with the proposed algorithm for an islanded microgrid with four units.

but successfully regulates frequency and voltage deviations caused by load variations.

B. Effect of Packet Losses

To evaluate the impact of erroneously received or lost broadcast packets on the performance of the proposed scheme, we have applied a packet loss probability of a 95%. This is exceptionally high and, practically, at the edge of making the link in-existent. Fig. 7 illustrates the effect of the packet losses

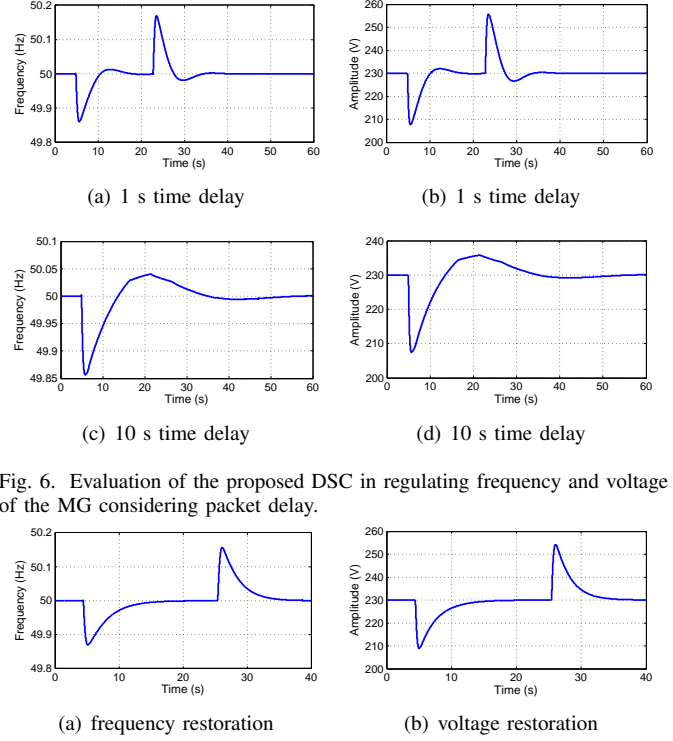

Fig. 6. Evaluation of the proposed DSC in regulating frequency and voltage of the MG considering packet delay.

Fig. 7. Evaluation of proposed DSC in regulating frequency and voltage of the MG considering packet losses.

over the frequency and voltage response of the system when a 200Ω is connected and then disconnected quickly. It is clear from the figure that the proposed scheme is robust against high probability of packet losses as voltage and frequency of the MG is properly regulated. The reason is that the proposed algorithm calculates the averages only with correct signals and neglects erroneous ones. One should note that lower packet loss probability had virtually no effect on the performance of the proposed algorithm in the examined setup.

V. EXPERIMENTAL RESULTS

An islanded power electronic based MG consisting of two units was built and tested in the laboratory as a case study in order to evaluate the performance of the proposed algorithm experimentally. The scheme of the experimental setup of an islanded MG system is shown in Fig. 8, in which two Danfoss 2.2 kW voltage source inverters operating in parallel at 10 kHz with LCL output filters, supply power to a diode rectifier loaded by a 200Ω resistor. The primary and secondary control strategies were implemented in Matlab Simulink[®], and dSPACE[®] 1103 which is a real time platform used as an interface between the electrical part and control part. The proposed algorithm was modeled in Matlab Stateflow[®]. The electrical setup and control system parameters are the same as the simulation part listed in Table IV.

Several experimental tests were carried out to validate the effectiveness robustness of the proposed scheme. Similar to the simulation results, the experimental results have been extracted from dSPACE control desk[®], but plotted using MATLAB[®].

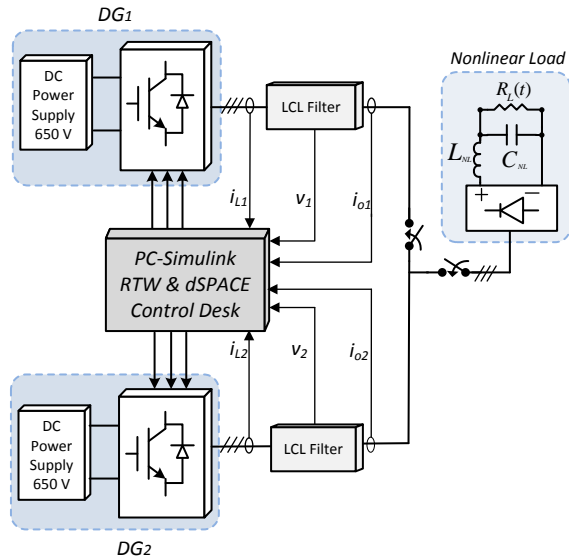
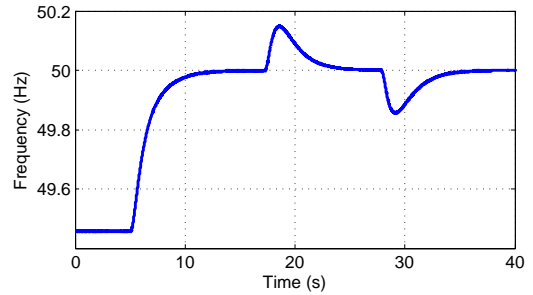

Fig. 8. Scheme of experimental setup of an islanded MG with two units.

Fig. 9 represents the dynamic response of MG system examined for three different scenarios similar to those performed in Section IV. During the first one, only primary control is running and the DSC is not enabled. As shown in Fig. 9, not only P-f and Q-V droops deviate frequency and voltage of the MG, but also poor reactive power sharing between units is exhibited. Nevertheless, active power is shared properly between units using the P-f droop since the frequency is the same in the whole MG. When the proposed DSC is enabled at $t = 5$ s, frequency and voltage are restored successfully, and reactive power is well shared. In the last scenario, the proposed controller regulates the system frequency and voltage perfectly, following load disturbances, as well as keeping active and reactive power sharing between the units. It is worth noting that the small difference between voltage amplitude of the units is because of the voltage error due to the calibration.

Fig. 10 shows the impact of the information delay when regulating frequency and voltage in the experimental setup with frequent load step changes. Left column of the figure is dedicated to the frequency response and right column shows the voltage amplitude restoration by the DSC when the delay is 1 s. The results for the delay of 20 s is examined as the worst case and the corresponding responses are presented in Fig. 10(c) and Fig. 10(d). Overall, the experimental results show that the proposed DSC is robust and able to maintain the system stability; the increased delay affects only the settling time of restoration process.

The experimental validation of the proposed controller when packet loss probability is set to 95% is depicted in Fig. 11; the figure shows frequency and voltage amplitude of the system during load variation. In this validation test, a 0.5 s fixed delay was introduced in order to make the experiments more realistic.



(a) frequency restoration

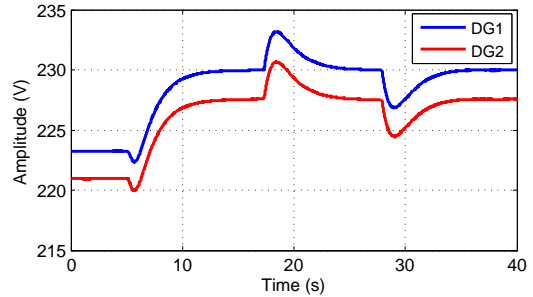

(b) voltage restoration

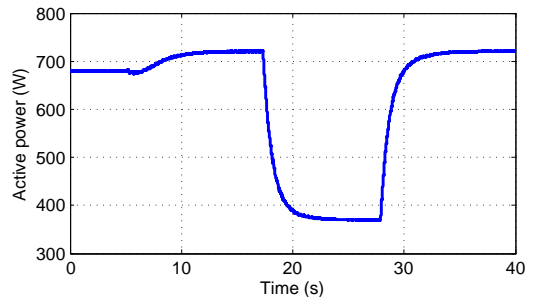

(c) active power sharing

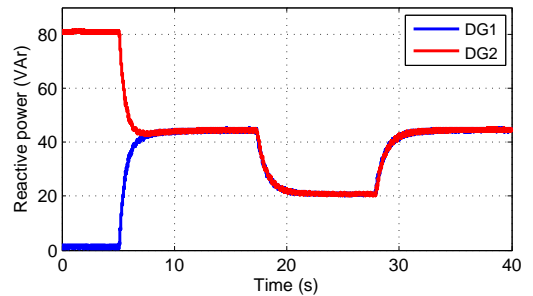

(d) reactive power sharing

Fig. 9. Experimental validation of proposed algorithm for DSC of an islanded MG with two DGs.

VI. CONCLUSION

In this paper, a distributed algorithm for combined communication/secondary control for islanded MGs. The algorithm is based on local averaging, while each unit best an opportunity to broadcast its local value in a round robin manner. The distributed operation and the tight coupling between communication and control makes the system very robust, as it removes the feature of having a single point of failure.

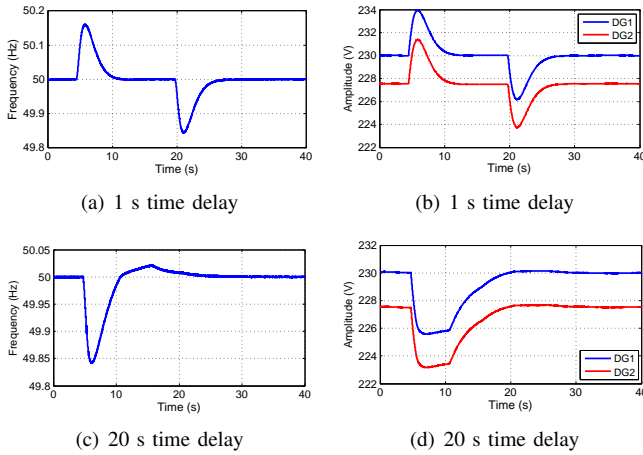

Fig. 10. Experimental evaluation of the proposed DSC in regulating frequency and voltage of the MG considering packet delay.

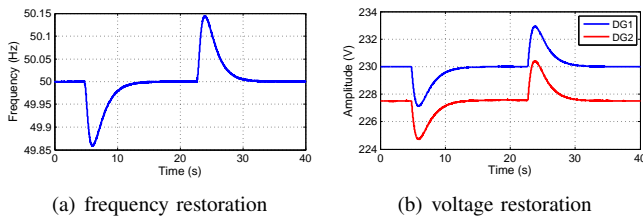

Fig. 11. Evaluation of proposed DSC in regulating frequency and voltage of the MG considering packet losses.

In this wireless-communication based algorithm, every agent calculates a new average of data in every sample time by combining the received information from other agents with its own measurements. The properties of the proposed DSC approach were evaluated at first through PHIL simulations on a four-units paralleled autonomous MG case study. Simulation results verified that the proposed DSC method can successfully restore frequency and voltage of the system and properly equalize reactive power in the low R/X MGs even in presence of communication delays and data packet losses. Indeed, the results showed a negligible overshoot, with slower frequency and voltage recovery to the nominal value. Finally, a small-scale experimental setup that consists of two parallel units has been assembled in the lab in order to confirm the validity of simulation results. It turned out that the simulation and experimental results are fairly well matched, thereby confirming the practical utility of the proposed approach.

REFERENCES

- [1] J. M. Guerrero, J. C. Vasquez, J. Matas, M. Castilla, L. G. D. Vicua, and M. Castilla, "Hierarchical Control of Droop-Controlled AC and DC Microgrids—A General Approach Toward Standardization", *IEEE Trans. Ind. Electron.*, vol.58, no.1, pp.158–172, Jan. 2011.
- [2] J. A. P. Lopes, C. L. Moreira, and A. G. Madureira, "Defining control strategies for microgrids islanded operation", *IEEE Trans. Power Syst.*, vol. 21, pp. 916–924, May 2006.
- [3] C. Yuen, A. Oudalov, and A. Timbus, "The provision of frequency control reserves from multiple microgrids", *IEEE Trans. Ind. Electron.*, vol. 58, pp. 173–183, Jan. 2011.
- [4] Y. A. R. I. Mohamed and A. A. Radwan, "Hierarchical control system for robust microgrid operation and seamless mode transfer in active

- distribution systems", *IEEE Trans. Smart Grid*, vol. 2, pp. 352–362, Jun. 2011.
- [5] F. Katiraei, M. R. Irvani, and P. W. Lehn, "Microgrid autonomous operation during and subsequent to islanding process", *IEEE Trans. Power Del.*, vol. 20, pp. 248–257, Jan. 2005.
- [6] P. Piagi and R. H. Lasseter, "Autonomous control of microgrids", in *Proc. IEEE Power Eng. Soc. General Meeting*, 2006.
- [7] A. Mehrizi-Sani and R. Irvani, "Potential-function based control of a microgrid in islanded and grid-connected models", *IEEE Trans. Power Syst.*, vol. 25, pp. 1883–1891, Nov. 2010.
- [8] A. Madureira, C. Moreira, and J. P. Lopes, "Secondary load-frequency control for microGrids in islanded operation", in *Proc. ICREPQ*, Frankfurt, Germany, pp. 1–4, 2005.
- [9] J. M. Guerrero, P. Loh, M. Chandorkar, T. Lee, "Advanced Control Architectures for Intelligent MicroGrids—Part I: Decentralized and Hierarchical Control", *IEEE Trans. Ind. Electron.*, vol.60, no.4, pp.1263–1270, April 2013.
- [10] J. Vasquez, J. M. Guerrero, M. Savaghebi, J. Eloy-Garcia, R. Teodorescu, "Modeling, Analysis, and Design of Stationary Reference Frame Droop Controlled Parallel Three-Phase Voltage Source Inverters", *IEEE Trans. Ind. Electron.*, vol.60, no.4, pp.1271–1280, April 2013.
- [11] Q. Shafiee, J. Vasquez, J. M. Guerrero, "Distributed secondary control for islanded MicroGrids - A networked control systems approach", in *Proc. of IECON*, Montreal, Canada, pp. 5637–5642, 2012.
- [12] Q. Shafiee, J. M. Guerrero, J. C. Vasquez, "Distributed Secondary Control for Islanded MicroGrids - A Novel Approach," *IEEE Trans. power Electron.*, 2013, Early access.
- [13] A. Micallef, M. Apap, C. Spiteri-Staines, J. M. Guerrero, "Secondary Control for Reactive Power Sharing in Droop-Controlled Islanded MicroGrids", in *Proc. IEEE ISIE*, 2012.,
- [14] F. Katiraei, R. Irvani, N. Hatzigiorgiou, A. Dimeas, "Microgrids management", *IEEE Power Energy Mag.*, vol.6, no.3, pp.54–65, 2008.
- [15] A.G.Tsikakakis, N.D. Hatzigiorgiou, "Centralized Control for Optimizing Microgrids Operation", *IEEE Trans. Energy Convers.*, vol.23, no.1, pp.241–248, March 2008.
- [16] A. Olshevsky and J. N. Tsitsiklis, "Convergence Speed in Distributed Consensus and Averaging", *SIAM J. Control Optim.*, vol. 48, no. 1, pp. 33?–55, Feb. 2009.
- [17] H. Liang, B. J. Choi, W. Zhuang and X. Shen, "Decentralized Inverter Control in Microgrids Based on Power Sharing Information through Wireless Communication", in *Proc. IEEE GLOBECOM 2012*, Anaheim, CA, USA, Dec. 2012.
- [18] H. Liang, B. J. Choi, W. Zhuang, X. Shen and A. S. Awad, "Multi-agent coordination in microgrids via wireless networks", *IEEE Wireless Commun.*, vol. 19, no. 3, pp. 14–22, June 2012.
- [19] A. D. Dominguez-Garcia, C. N. Hadjicostis and N. H. Vaidya, "Resilient Networked Control of Distributed Energy Resources", *IEEE IEEE J. Sel. Areas Commun.*, vol. 30, no. 6, pp. 1137–1148, July 2012.
- [20] H. Bevrani, *Robust Power System Frequency Control*, Springer, New York, USA, 2009.
- [21] N. Varanese, *Distributed Synchronization Algorithms for Wireless Sensor Networks*, PhD Thesis, New Jersey Institute of Technology, New Jersey, USA, 2011.
- [22] J. E. Wieselthier, G. D. Nguyen, A. Ephremides, "On the construction of energy-efficient broadcast and multicast trees in wireless networks", in *Proc. of IEEE INFOCOM 2000*, vol. 2, pp. 585–594, Tel Aviv, Israel, March 2000.