

Online Selective Harmonic Minimization for Cascaded Half-Bridge Multilevel Inverter Using Artificial Neural Network

Payam Farhadi¹, Mohammad Navidi², Milad Gheydi³, Mehdi Pazhoohesh⁴, Hassan Bevrani²

¹Department of Electrical Engineering, Parsabad Moghan Branch, Islamic Azad University, Parsabad Moghan, Iran

²Department of Electrical and Computer Engineering, University of Kurdistan, Sanandaj, Iran

³IEEE Student Member, Department of Electrical Engineering, Science and Research Branch, Islamic Azad University, Tehran, Iran

⁴Department of Engineering, University of Liverpool, Liverpool, UK

Abstract— Selective harmonic elimination (SHE) is a widely used method to minimize the amount of total harmonic distortion (THD) in multilevel inverters. The main challenge associated with SHE method is to solve multiple variable high order nonlinear equations to obtain desired switching angles. To overcome this problem, a new online approach is provided in this paper which does not require solving complex nonlinear equations. In this method, artificial neural networks (ANNs) are used to determine the switching angles to minimize the THD amount of the ac side voltage of an 11-level cascaded Half-bridge (CHB) multilevel inverter. However, unlike offline methods, ANN is updated online, without using any data gained from solving SHE equations. Finally, Simulation results are illustrated and compared with other offline methods.

Keywords— Artificial Neural Network; Total Harmonic Distortion; Selective Harmonic Elimination; Cascaded Half Bridge Multilevel Inverter; Online Approach

I. INTRODUCTION

In recent years, multilevel inverters have gained much attention in medium voltage and high power applications due to their advantageous such as lower common mode voltage, lower voltage stress on power switches and lower dv/dt ratio. The most common multilevel inverter topologies classified into three types are diode clamped, flying capacitor, and cascaded Half-Bridge multilevel inverter [1].

To minimize the total harmonic distortion (THD) amount, various pulse-width modulation (PWM) techniques are presented. The most common PWM techniques are selected harmonic elimination (SHE), total harmonic distortion minimization, sinusoidal triangle, and space vector modulation techniques [2]. SHE-PWM is widely used in multilevel inverter control due to low switching frequency, direct control over low-order harmonics and better DC source utilization. The main drawback of this method is the complexity of solving high order nonlinear equations [3]. To solve this problem, several solutions have been presented which are commonly divided into two categories, analytical and optimization based methods.

Among analytical methods, Newton-Raphson technique is a common one. It is one of the fastest iterative methods to solve nonlinear equations. However, the results depend on the initial guess, which is a major drawback [7-8].

A modified SHE-PWM technique extends the standard modulation region by reducing the number of transcendental equations [2]. In [4], a generalized formulation is proposed for SHE-PWM control offers more degrees of freedom and improves the performance of the converter, suitable for high-voltage high-power cascaded multilevel voltage source converters with both equal and non-equal dc sources used in constant frequency utility applications.

A novel formulation of multilevel SHE-PWM technique is presented in [5] so that the degrees of freedom for specifying the cost function are increased. With the proposed approach, the solution of the switching angles can be sought for the entire range of the modulation index without affecting the number of harmonics being eliminated or the number of the output voltage levels. In [6], the authors developed harmonics injection and equal area criteria-based four-equation method to realize optimal PWM. The proposed method does not involve complex equation groups and is much easier to be utilized in the case of large number of switching angles, or multiple switching angles per voltage level in multilevel inverters.

Another method presented in [9], namely phase-inversion-based selective harmonic elimination, is used to eliminate selected harmonics and their integer multiples in tone excitation signals and extends this methodology to generate the frequency modulated excitation signals.

By applying a unified approach, the complete sets of solutions to polynomial equations are found and those who results in the smallest value of the THD computed are considered as a switching angle [10].

There are also many literatures on optimization based methods to solve the SHE equations.

In [11] and [12], Genetic algorithm is applied to solve the SHE equation. Also, a Bee optimization method is applied to a 7-level inverter for solving the nonlinear equations [13]. This

method has higher precision and probability of convergence than the genetic algorithm.

In recent articles, artificial neural network (ANN) is proposed for real time control of multilevel inverters [14-16]. In [14], the switching angles data calculated by Newton-Raphson method are used to train the ANN to minimize the voltage THD of the 9-level inverter. In [15], different data sets of angle values are obtained for cascaded H bridge multilevel inverter used to train the multi-layered feed forward neural network to control the converter. Another real time ANN technique is used to generate the switching angles in an 11-level full-bridge cascade inverter powered by five varying dc input solar panel sources [16].

In all of the previous works, solving the nonlinear trigonometric equations of the SHE problem is inevitable even by using ANN. The main goal of this article is to maintain the minimum THD and desired main harmonic component, without solving SHE equations. This goal is achieved by online training of the multilayer ANN.

This paper is organized as follows. Section II presents the formulation of SHE-PWM for 11-level cascaded Half-bridge (CHB) multilevel inverter. Section III discusses the ANN structure and its training method. Simulation results are shown in Section IV. Finally, conclusions are summarized in Section V.

II. MULTILEVEL INVERTER

Cascaded half bridge multilevel inverter has the minimum power switches in comparison with other conventional multilevel inverters. This structure is based on series half bridge modules with isolated DC voltage sources. This converter could be useful for fuel cell or photovoltaic

applications, due to separated DC sources [1].

An 11-level CHB multilevel inverter and its output voltage are shown in Fig. 1. Three voltage levels of $-V_{DC}$, 0 and $+V_{DC}$ are attainable for each module by different switching strategies. If n defines the number of series half bridge modules, m shows the output voltage levels of the multilevel inverter and is calculated as follows [1]:

$$m = 2n + 1 \quad (1)$$

To reduce the harmonic components of the output voltage by SHE method, switching angles should be determined to gain the desired output voltage, while low order harmonics become zero. By using Fourier series, the output voltage of the inverter is given by [1]:

$$V(\omega t) = \sum_{n=1,3,5,\dots}^{\infty} \frac{4V_{dc}}{n\pi} \left(\begin{array}{l} (\cos(n\theta_1) + \cos(n\theta_2) \\ + \cos(n\theta_3) + \cos(n\theta_4) \\ + \cos(n\theta_5) \end{array} \right) \sin(n\omega t) \quad (2)$$

where θ_i is the switching angle of switch i . To eliminate the 5th, 7th, 11th and 13th harmonic orders of an 11-level converter, the switching angles should be found to fulfill the following equations [1].

$$\begin{aligned} \cos(\theta_1) + \cos(\theta_2) + \cos(\theta_3) + \cos(\theta_4) + \cos(\theta_5) &= 5M_1 \\ \cos(5\theta_1) + \cos(5\theta_2) + \cos(5\theta_3) + \cos(5\theta_4) + \cos(5\theta_5) &= 0 \\ \cos(7\theta_1) + \cos(7\theta_2) + \cos(7\theta_3) + \cos(7\theta_4) + \cos(7\theta_5) &= 0 \\ \cos(11\theta_1) + \cos(11\theta_2) + \cos(11\theta_3) + \cos(11\theta_4) + \cos(11\theta_5) &= 0 \\ \cos(13\theta_1) + \cos(13\theta_2) + \cos(13\theta_3) + \cos(13\theta_4) + \cos(13\theta_5) &= 0 \end{aligned} \quad (3)$$

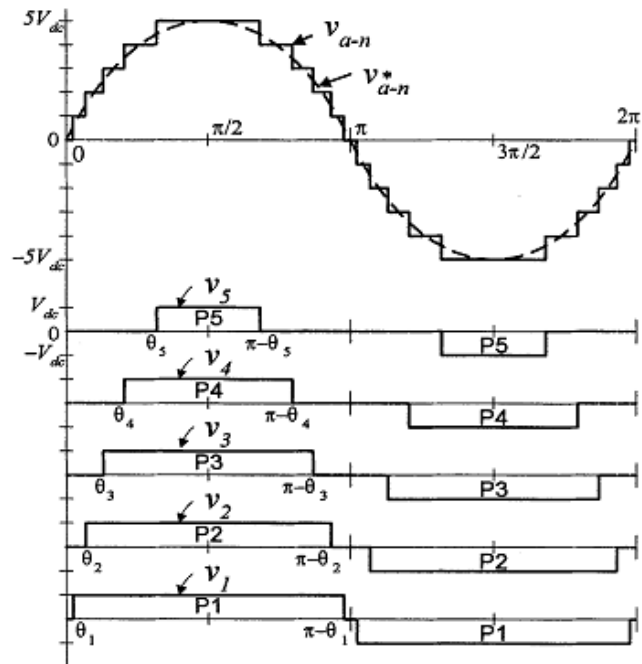
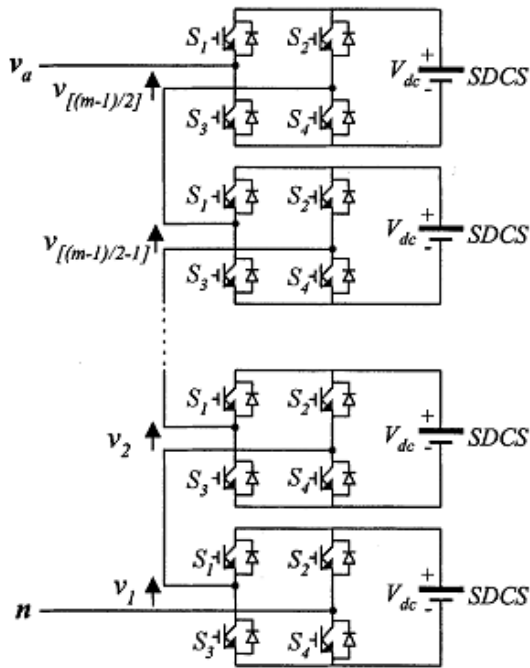

Fig. 1. CHB multilevel inverter and its output voltage [10]

where the modulation index is given by [2]:

$$M_f = \frac{\pi V_1}{20V_{dc}} \quad (4)$$

where V_1 is the main component of output voltage.

Total harmonic distortion factor is used to compare the harmonic components of the output voltages. THD is defined as follows [7]:

$$THD = \frac{\sqrt{V_2^2 + V_3^2 + V_4^2 + \dots}}{V_1} \quad (5)$$

where V_i is the i^{th} order harmonic of output voltage.

III. ANN

The ANN used in this paper contains two hidden layer, one input layer and one output layer. Each hidden layer consists of ten neurons and both input and output layers consist of five neurons. The output of each neuron is given by [17]:

$$y(k) = f\left(\sum_{j=1}^n W_j x_j(k) + b\right) \quad (6)$$

where x is the input of the neuron, W is the weight of the input, b is the bias, and n is the number of neurons in each layer. f is the function of a neuron that is a linear function for the input and output layers and a sigmoid function for two hidden layers. The ANN structure used in this paper is shown in Fig. 2.

ANN output determines the switching angles of the 11-level CHB inverter. The main component and the harmonics of 5th, 7th, 11th and 13th order gained by these switching angles are compared with the reference voltage. The error function is calculated as follows:

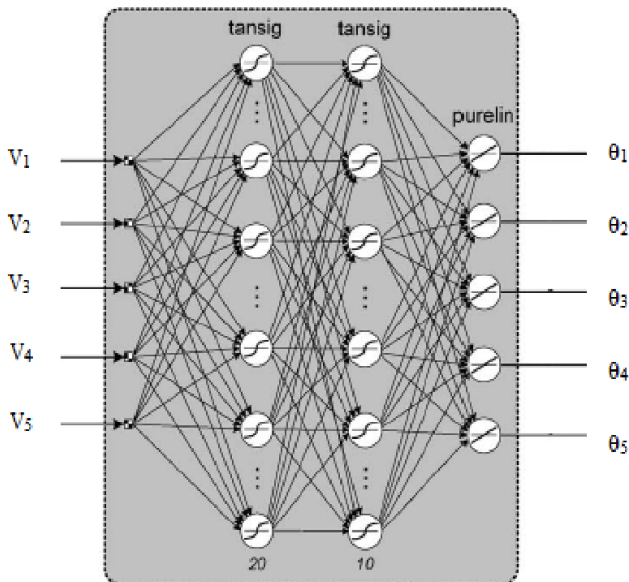

Fig. 2. Artificial neural network structure [15]

$$E = \frac{1}{2} \left[(V_{1ref} - V_1)^2 + V_5^2 + V_7^2 + V_{11}^2 + V_{13}^2 \right] \quad (7)$$

where V_{1ref} is the desired output voltage. By minimizing this error function, the amount of 5th, 7th, 11th, and 13th voltage harmonics minimizes, which results into minimum THD.

Back propagation method is used to train the ANN. The weight update formula for the route between the i^{th} neuron of a layer and the j^{th} neuron of the next layer is given by [17]:

$$W_{ij}(k+1) = W_{ij}(k) + \Delta W_{ij} \quad (8)$$

where k is the number of iterations. By using gradient decent method, ΔW_{ij} is calculated as follows [17]:

$$\Delta W_{ij} = -\eta \frac{\partial E}{\partial W_{ij}} \quad (9)$$

where η is the learning rate, which is considered one in this paper, to speed up the convergence. Chain rule is applied to calculate the $\frac{\partial E}{\partial W_{ij}}$. By using this method, ΔW_{ij} is given by [17]:

$$\Delta W_{ij} = -\eta \frac{\partial E}{\partial O_j} \frac{\partial O_j}{\partial net_j} \frac{\partial net_j}{\partial W_{ij}} \quad (10)$$

By extending this method to other layers, all of the weights are updated. The inputs of the first layer play a key role in training pace of the ANN. The weights are updated from the last layer to first layer in back propagation method, so the effect of the outputs is transmitted to the input. Therefore, the amount of the first input is chosen close to the desired output voltage. Also, the amounts of the other inputs are selected near zero, because the harmonics are expected to be as low as possible. Whatever the difference between the inputs and the references becomes lower, the ANN is trained faster.

IV. SIMULATION

11-level CHB multilevel inverter is used to examine the accuracy of the online ANN approach. Five 100 volts DC voltage sources are considered as the inputs of the each phase of the converter. Phase to phase CHB multilevel inverter's output voltage and its harmonic components are shown in Fig. 3, for modulation indices of 0.55 and 0.7. As demonstrated in Fig. 3, the 5th, 7th, 11th and 13th order harmonics are limited to very low amounts, resulted in the THD amounts of 7.24% and 7% respectively. To compare the results, offline method is implemented to control an 11-level CHB multilevel inverter to minimize the THD amount. In this strategy, equations (3) are solved by Newton-Raphson method, for different modulation Indices. Finally, resulted data are utilized to train an ANN to control the inverter. Phase to phase output voltage of the multilevel inverter and its harmonic components for offline method are shown in Fig. 4. Refer to Fig. 4, THD amount for modulation indices of 0.55 and 0.7 are 7.78% and 7.17% respectively. It could be seen that for both modulation indices,

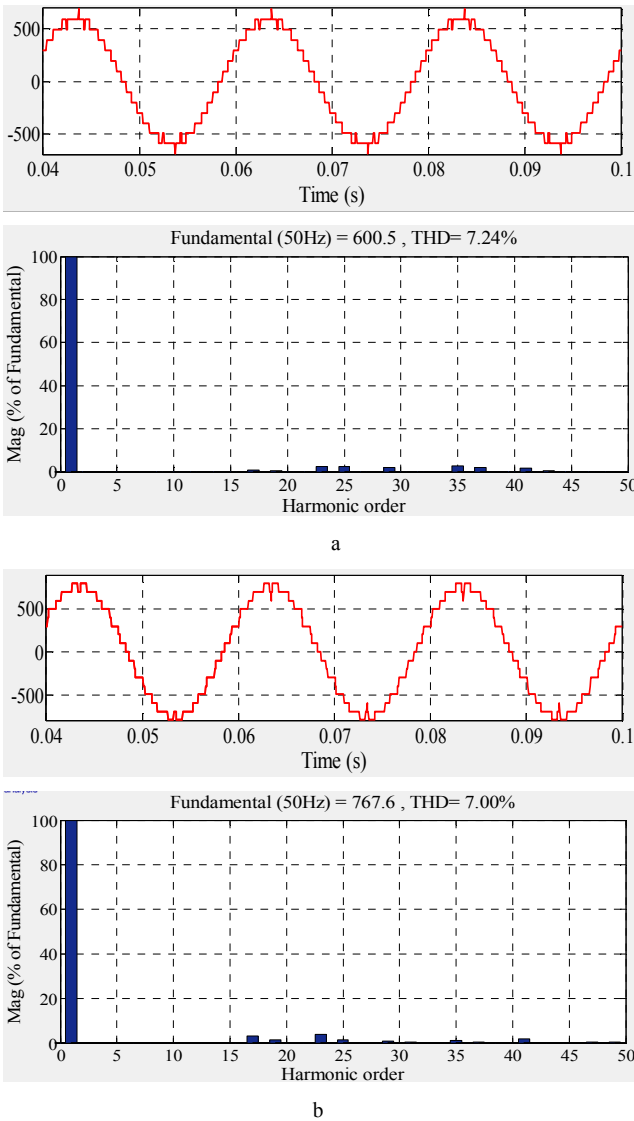

Fig. 3. Phase to Phase voltage and harmonic components of the online method for modulation indices of a) 0.55 and b) 0.7

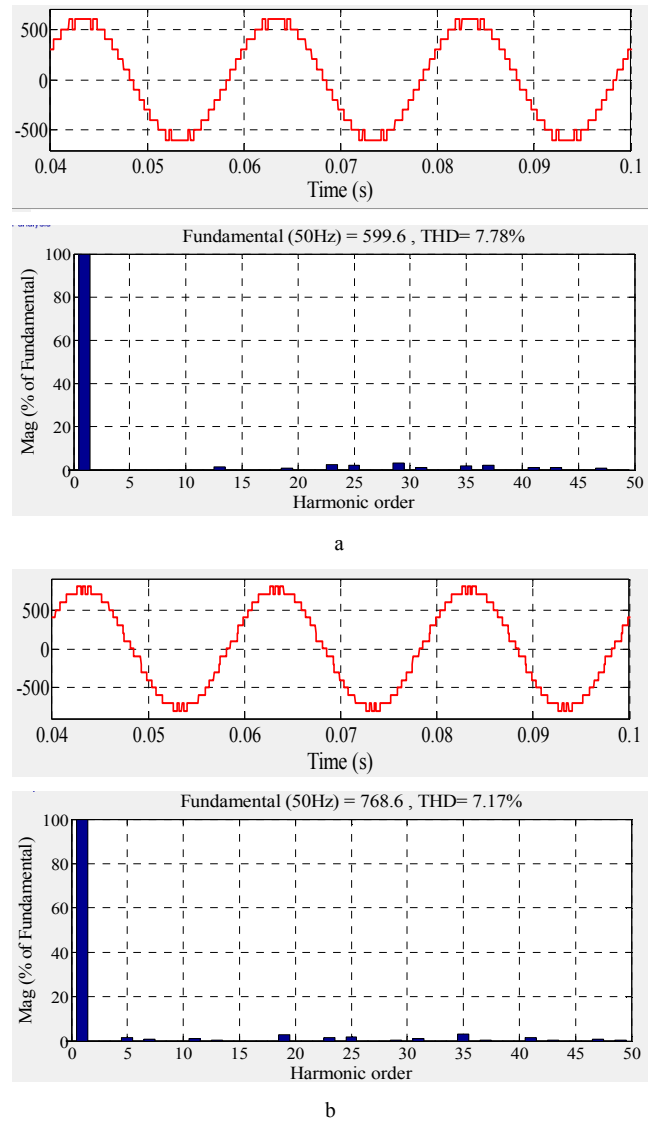

Fig. 4. Phase to Phase voltage and harmonic components of the offline method for modulation indices of a) 0.55 and b) 0.7

the THD amount of the online method is significantly lower than the offline one.

In addition to these two modulation indices, THD amounts for different feasible modulation indices for online and offline methods are illustrated in Table I. As shown in Table I, the THD amount of online approach is lower than offline method for the entire modulation index range. Switching angles of the 11-level CHB multilevel inverter with online control is shown in Fig. 5.

As mentioned before, lower THD amount is not the only advantage of the online method. Besides that, unlike the offline method, there is no need for any calculation to solve complex nonlinear equations, and the ANN is trained online, using back-propagation technique.

TABLE I. THD% AMOUNT OF THE ONLINE AND OFFLINE METHODS

Modulation Index	THD%	
	Online method	Offline Method
0.43	9.5	9.72
0.45	9.04	9.33
0.50	8.25	8.59
0.55	7.24	7.78
0.60	7.17	7.42
0.65	7.11	7.3
0.70	7	7.17
0.75	6.03	6.12
0.80	5.84	5.93
0.85	6.21	6.86

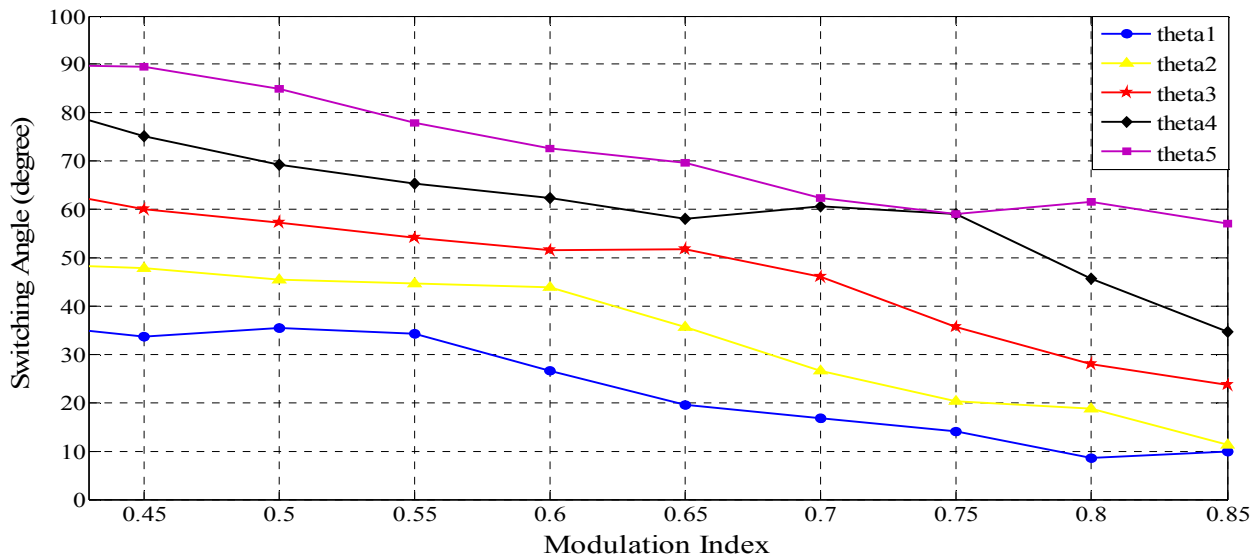

Fig. 5. Switching angles of the 11-level CHB multilevel inverter with online control approach

V. CONCLUSION

A new ANN based online approach has been proposed to solve the SHE problem in 11-level cascaded Half-bridge multilevel inverter. By applying this method, there is no need for any complicated SHE equations to be solved. By using back propagation method for ANN training, appropriate switching angles are obtained online, to minimize the THD amount and fulfill the desired output voltage. THD amounts of the online approach compared with offline method, shows a significant decrease in harmonic components in online approach.

REFERENCES

- [1] Ilhami Colak, Ersan Kabalci, Ramazan Bayindir, Review of multilevel voltage source inverter topologies and control schemes, *Energy Conversion and Management*, Volume 52, Issue 2, February 2011, Pages 1114-1128, ISSN 0196-8904.
- [2] Farokhnia, N.; Fathi, S.H.; Salehi, R.; Gharehpetian, G.B.; Ehsani, M., "Improved selective harmonic elimination pulse-width modulation strategy in multilevel inverters," *Power Electronics, IET*, vol.5, no.9, pp.1904,1911, November 2012
- [3] Dahidah, M.S.A.; Konstantinou, G.S.; Agelidis, V.G., "Selective harmonic elimination pulse-width modulation seven-level cascaded H-bridge converter with optimised DC voltage levels," *Power Electronics, IET*, vol.5, no.6, pp.852,862, July 2012.
- [4] Dahidah, Mohamed S.A; Agelidis, V.G., "Selective Harmonic Elimination PWM Control for Cascaded Multilevel Voltage Source Converters: A Generalized Formula," *Power Electronics, IEEE Transactions on*, vol.23, no.4, pp.1620,1630, July 2008.
- [5] Dahidah, M.S.A.; Konstantinou, G.S.; Agelidis, V.G., "Selective harmonic elimination pulse-width modulation seven-level cascaded H-bridge converter with optimised DC voltage levels," *Power Electronics, IET*, vol.5, no.6, pp.852,862, July 2012.
- [6] Ahmadi, D.; Ke Zou; Cong Li; Yi Huang; Jin Wang, "A Universal Selective Harmonic Elimination Method for High-Power Inverters," *Power Electronics, IEEE Transactions on*, vol.26, no.10, pp.2743,2752, Oct. 2011.
- [7] Hossam, R.M.; Hashem, G.M.; Marei, M.I., "Optimized harmonic elimination for cascaded multilevel inverter," *Power Engineering Conference (UPEC), 2013 48th International Universities'*, vol., no., pp.1,6, 2-5 Sept. 2013.
- [8] Krismadinata, Nasrudin Abd Rahim, Hew Wooi Ping, Jeyraj Selvar aj, Elimination of Harmonics in Photovoltaic Seven-level Inverter with Newton-raphson Optimization, *Procedia Environmental Sciences*, Volume 17, 2013, Pages 519-528, ISSN 1878-0296.
- [9] Cowell, D.M.J.; Smith, P.R.; Freear, S., "Phase-inversion-based selective harmonic elimination (PI-SHE) in multi-level switched-mode tone- and frequency- modulated excitation," *Ultrasonics, Ferroelectrics, and Frequency Control, IEEE Transactions on*, vol.60, no.6, pp.1084,1097, June 2013.
- [10] Chiasson, J.N.; Tolbert, L.M.; McKenzie, K.J.; Zhong Du, "A unified approach to solving the harmonic elimination equations in multilevel converters," *Power Electronics, IEEE Transactions on*, vol.19, no.2, pp.478,490, March 2004.
- [11] Debnath, S.; Ray, R.N., "Harmonic elimination in multilevel inverter using GA and PSO: A comparison," *Electrical, Electronics and Computer Science (SCECS), 2012 IEEE Students' Conference on*, vol., no., pp.1,5, 1-2 March 2012.
- [12] Khaled El-Naggar, Tamer H. Abdelhamid, Selective harmonic elimination of new family of multilevel inverters using genetic algorithms, *Energy Conversion and Management*, Volume 49, Issue 1, January 2008, Pages 89-95, ISSN 0196-8904
- [13] Kavousi, A.; Vahidi, B.; Salehi, R.; Bakhshizadeh, M.; Farokhnia, N.; Fathi, S.S., "Application of the Bee Algorithm for Selective Harmonic Elimination Strategy in Multilevel Inverters," *Power Electronics, IEEE Transactions on*, vol.27, no.4, pp.1689,1696, April 2012.
- [14] Khoukha, I.; Hachemi, C.; El Madjid, B., "ANN control of nine level NPC voltage inverter based on selective harmonics elimination," *Electrical Machines and Power Electronics, 2007. ACEMP '07. International Aegean Conference on*, vol., no., pp.587,591, 10-12 Sept. 2007.
- [15] Aravind, P.S.; Alexander, S.A., "Harmonic minimization of a solar fed cascaded H Bridge inverter using Artificial Neural Network," *Energy Efficient Technologies for Sustainability (ICEETS), 2013 International Conference on*, vol., no., pp.163,167, 10-12 April 2013.
- [16] Filho, F.; Tolbert, L.M.; Yue Cao; Ozpineci, B., "Real-Time Selective Harmonic Minimization for Multilevel Inverters Connected to Solar Panels Using Artificial Neural Network Angle Generation," *Industry Applications, IEEE Transactions on*, vol.47, no.5, pp.2117,2124, Sept.-Oct. 2011.
- [17] M. T. Hagan, H. B. Demuth, and M. H. Beale, *Neural network design* vol. 1: Pws Boston, 1996.