

**University of Kurdistan**  
Dept. of Electrical Engineering  
Smart/Micro Grids Research Center  
[smgrc.uok.ac.ir](http://smgrc.uok.ac.ir)

## **A Novel Design of Decentralized LFC to Enhance Frequency Stability of Egypt Power System Including Wind Farms**

G. Magdy, G. Shabib, Adel A. Elbaset, Thongchart Kerdphol, Yaser Qudaih, Hassan Bevrani, Yasunori Mitani

Published (to be published) in: **International Journal on Energy Conversion (I.R.E.CON.), Vol. 6, N. 1**  
**ISSN 2281-5295**

(Expected) publication date: **March 2019**

### **Citation format for published version:**

G. Magdy, G. Shabib, Adel A. Elbaset, Thongchart Kerdphol, Yaser Qudaih, Hassan Bevrani, Yasunori Mitani. (2019). A Novel Design of Decentralized LFC to Enhance Frequency Stability of Egypt Power System Including Wind Farms. *International Journal on Energy Conversion (I.R.E.CON.), Vol. 6, N. 1* ISSN 2281-5295, 13.

### **Copyright policies:**

- Download and print one copy of this material for the purpose of private study or research is permitted.
- Permission to further distributing the material for advertising or promotional purposes or use it for any profitmaking activity or commercial gain, must be obtained from the main publisher.
- If you believe that this document breaches copyright please contact us at [smgrc@uok.ac.ir](mailto:smgrc@uok.ac.ir) providing details, and we will remove access to the work immediately and investigate your claim.

## A Novel Design of Decentralized LFC to Enhance Frequency Stability of Egypt Power System Including Wind Farms

G. Magdy<sup>1,2</sup>, G. Shabib<sup>2,3</sup>, Adel A. Elbaset<sup>4</sup>, Thongchart Kerdphol<sup>1</sup>, Yaser Qudaih<sup>5</sup>, Hassan Bevrani<sup>6</sup>, Yasunori Mitani<sup>1</sup>

**Abstract** – This paper presents a real hybrid power system in Egypt, which includes both conventional generation units and Renewable Energy Sources (RESs) for studying the Load Frequency Control (LFC) problem. The conventional generation system in the Egyptian Power System (EPS) is decomposed into three dynamic subsystems; non-reheat, reheat and hydro power plants. Moreover, real wind speed data extracted from Zafarana location in Egypt is used for achieving a realistic wind power study. Each subsystem of the EPS has its own characteristics compared to the others. Moreover, the physical constraints of the governors and turbines such as Generation Rate Constraints (GRCs) of power plants and speed governor dead band (i.e., backlash) are taken into consideration. Therefore, this paper proposes a decentralized controller for each subsystem independently, to guarantee the stability of the overall closed-loop system. Hence, an optimal PID controller-based Particle Swarm Optimization (PSO) algorithm is proposed for every subsystem separately to regulate the frequency and track the load demands of the EPS. The performance of the proposed decentralized controller of each subsystem is compared to the centralized one under different operational scenarios. The EPS is tested using the nonlinear simulation by Matlab/SIMULINK. The obtained results reveal the superior robustness of the proposed decentralized controller against different load disturbance patterns, real wind power fluctuations and EPS uncertainties. **Copyright © 2018 Praise Worthy Prize S.r.l. - All rights reserved.**

**Keywords:** Load Frequency control (LFC), Decentralized Control, Egyptian Power System, Particle Swarm Optimization (PSO)

### Nomenclature

		$P_{n1}$	Nominal rated Power output for the non-reheat plant (MW pu)
$\Delta f$	The frequency deviation of the EPS (Hz)	$P_{n2}$	Nominal rated Power output for the reheat plant (MW pu)
$D$	System damping coefficient (pu MW/Hz)	$P_{n3}$	Nominal rated Power output for the hydro plant (MW pu)
$H$	Equivalent inertia constant (pu s)	$\Delta P_{c1}$	Regulating the system frequency of the non-reheat plant (Hz)
$T_1$	Valve time constant of the non-reheat plant (s)	$\Delta P_{c2}$	Regulating the system frequency of the reheat plant (Hz)
$T_2$	Steam valve time constant of the reheat plant (s)		
$T_3$	Water valve time constant of the hydro plant (s)		

$T_d$	Dashpot time constant of the hydro plant speed governor (s)	$\Delta Pc3$	Regulating the system frequency of the hydro plant (Hz)
$T_h$	The time constant of the reheat thermal plant (s)	$VU$ $VL$	The maximum limit of the valve gate The minimum limit of the valve gate
$T_w$	Water starting time in hydro intake (s)		Number of plants
$\Delta P_L$	Load variation (MW pu)		Percentage of rotating load
$m$	The fraction of turbine power (intermediate pressure section)		Rotating inertia (s/Hz) Regulating power of plant i
$R_1$	Governor speed regulation non-reheat plant (Hz/pu MW)	( )	Number of units in plant i
( )	Inertia constant of a unit of plant i (pu MW)		
$R_2$	Governor speed regulation reheat plant (Hz/pu s/Hz)		
MW)			The current position of particle i at iteration n
$R_3$	Governor speed regulation hydro plant (Hz/pu MW)	$n$	Number of iterations
			pbest of particle i at iteration n

All rights reserved

<https://doi.org/10.15866/irecon.v6i1.14516>

	gbest of particle i at iteration n
	The velocity of particle i at iteration n
$c_1, c_2$	Acceleration constant
$w$	Inertia weight factor
$rand()$	A random number between 0 and 1
$T_{WT}$	Wind Turbine time constant (s)

## I. Introduction

The mismatch between electric power generation and load demand will eventually cause a frequency deviation as well as tie-line power deviation in the interconnected power system. Moreover, the large value of frequency deviation will cause many problems such as damaging the equipment, transmission line overloading and interference with system protection [1]. On the other hand, utilizing Renewable Energy Sources (RESs) is attracting great attention as a solution to future energy shortages. However, the irregular nature of RESs and random load deviations

cause many control problems. Moreover, if the penetration level of RESs is high, the system will suffer from reducing its inertia. This may lead to increase the system frequency deviation. Therefore, frequency control may be difficult in case of mismatch between electric power generation and load demand particularly with the growing penetration of RESs (e.g., wind and solar energy), which are integrated into power systems [2]. To solve such problem, Load Frequency Control (LFC) issue is introduced to maintain the system frequency at nominal value. This issue is considered one of the most important control strategies of power system operations, since it maintains system frequency and power variations at their standard values. The system frequency depends on active power, while voltage greatly depends on reactive power. Therefore, the control of power systems can be classified into two fundamental issues: a) control of the active power along

with frequency (i.e., LFC) and b) control of reactive power along with the regulation of voltage [3].

According to the most recent research, several control strategies were implemented in the LFC loops of different power systems. Sun et al. [4] used a robust  $H_\infty$  sliding mode control for the frequency stability enhancement of interconnected power systems. Yousef et al. [5] used an adaptive fuzzy logic approach-based LFC in multi-area interconnected power systems. Sayed et al. [6] used Linear Quadratic Regulator (LQR) with Kalman filter for automatic generation control in a restricted multi-area power system. Although the aforementioned control strategies gave a good dynamic response, they depend on designer's experience. Raheel et al. [7] tested the robustness of the Coefficient Diagram Method (CDM) controller beside the effect of Electric Vehicles (EV) in his control strategy for a small power system. Moreover, Princess et al. [8] studied the same control strategy in [7] for the modern power system. Tarek et al. [9] presented a combination of CDM and Ecological Optimal Technique (EOT) for LFC of the multi-area power system. However, the structure of the control technique in [7]-[9] is complicated, as it requires more steps to obtain its parameters. Kunya et al. [10] used Model Predictive Control (MPC) based LFC for the large interconnected power system. The predictive control strategy in [10] has the advantages of fast response, simple structure and easy handle system constraints and nonlinearities. However, it takes more time for the online calculations at each sampling time. On the other hand, most industrial applications are performed based on the

Proportional-Integral-Derivative (PID) controller due to its many merits, among which: economic cost, simplicity for parameters tuning, robustness and a successful practical controller, which can provide excellent control performance regardless of the perturbations and variations in the system parameters [11]. However, the PID controller suffers from a complicated process of parameters tuning based on the trial and error method. In such a case, the robustness of the system is not guaranteed against further perturbations in its parameters. Therefore, several optimization algorithms were used for finding the optimal parameters of the PID controller, such as Particle Swarm Optimization (PSO) [12], cuckoo optimization algorithm [13], ant colony Algorithm [14], etc [30].

According to the previous studies on the LFC issue, interconnected power systems were studied, such as thermal power plants (e.g., reheat and non-reheat turbines) and/or hydropower plants depending on the number of areas. However, most of the existing realistic power systems comprise multi-source dynamics generators: thermal, hydro, and gas power plants. Therefore, several types of power plants should be added to the LFC problem to achieve realistic studies as reported in this research. This requires using a decentralized control strategy, since the dynamic response of each type of power plant is different from the others. Furthermore, the centralized control

scheme is implemented with difficulty due to the excessive cost of transmitting data over the long distances as well as the errors, which might be caused accordingly [15]. Hence, the decentralized scheme is more accurate and realistic than the centralized control strategy. On the other hand, the model of the power system studied in [9]-[13] is a simple and linear system depending only on conventional generators. However, several RESs should be integrated into the interconnected power system to achieve more realistic study. Therefore, a few studies have faced the challenge of the integration of RESs into power systems by using different LFC control strategies. Hasanien et al. [16] presented a symbiotic organisms search algorithm for obtaining the optimal parameters of the frequency controller in the interconnected power system including wind farms. Hasanien [17] used the whale optimization algorithm for obtaining the optimal PID controller parameters in an interconnected modern power system including renewable sources.

Nowadays, RESs such as wind farms and solar power plants are attracting great attention as a solution for future energy shortages. Therefore, the modern power system is facing many challenges [18], [19]. According to the Global Wind Energy Council (GWEC), the installed wind power reached 52.5 GW in 2017. Moreover, the total installed wind power worldwide reached 539.5 GW at the end of 2017 [20], while the total Photovoltaics (PV) installation in Europe reached up to 156 GW in 2018, based on the global market outlook for photovoltaics [21]. Therefore, wind energy is the fastest growing and the most widely utilized in modern power systems as it has a lower installation cost compared to the photovoltaic system. Thus, wind energy represents a significantly larger portion of the installed electrical power from renewable energy. Hence, this research focuses on the effect of the integration of wind energy into the EPS on system frequency stability. Moreover, for achieving more realistic study, this research presents a real hybrid power system (i.e., The EPS) containing both conventional power plants and RESs (i.e., wind energy) for facing the frequency stability issue, while wind speed data are extracted from Zafarana location in Egypt [16].

Based on the above analysis, the main contribution of this work includes the following aspects: (i) it presents a real multi-source power system in Egypt, which consists of three dynamic subsystems (i.e., non-reheat, reheat, and hydro power plants) as well as the integration of wind energy for studying the LFC problem, in addition: inherent nonlinearities, speed governor dead band (i.e., backlash) and GRCs of each power plants are taken into consideration. (ii) the authors propose a decentralized control strategy as each subsystem in the EPS has its own characteristics compared to the others. Each subsystem in the EPS is considered as Single-Input Multi-Output (SIMO) and a decentralized controller is proposed for each subsystem independently. The proposed decentralized model is developed for the following

problems: a) unexpected external disturbances, b) non-linearity in the interactions, and c) system parameter variations due to changes in the operating conditions. (iii) the proposed decentralized frequency control is based on a robust PID controller, which is optimally designed by the Particle Swarm Optimization (PSO) algorithm. Finally (iv) a comparison between the proposed decentralized and the centralized model is studied to detect the merits and demerits of each model design.

The rest of this paper is arranged as follows: Section 2 describes the configuration and state equations of the EPS. The proposed control methodology for the studied system is presented in Section 3. Section 4 presents the simulation study. The simulation results-based on time demine are discussed in section 5. Finally, the conclusion is given in Section 6.

## II. Power System Overview and Modeling

### II.1. Dynamic Model of the EPS and State Equations

The power system presented in this study is a real power system in Egypt. It is divided into seven strongly tied zones: Cairo, Middle Egypt, Upper Egypt, East El-Delta, El-Canal, West El-Delta and Alexandria, as shown in Fig. 1. Each zone comprises several power plants (non-reheat, reheat, and hydro power plants or a combination of them). The EPS has more than 180 power plants, moreover it is classified into 3 categories: a) Non-reheat power plants represented by gas turbine power plants and a little number of steam power plants. b) Reheat power plants, mainly represented by thermal power plants or combined cycle power plants. c) Hydropower plants contribute for almost 14% of the installed capacity. In recent times, the EPS is combining several RESs such as wind turbines and solar power plants, which contribute by almost 3% of the installed capacity. However, in the future, the Egyptian Electricity Holding Company (EEHC) aims to increase the electric energy demand from RESs. The total generation capacity and peak loads are 35,220 MW and 28,015 MW, respectively, according to the annual report of the Egyptian Electricity Holding Company in 2015 [22]. The National Energy Control Center (NECC) in Egypt has implemented an advanced dynamic model of LFC for the EPS, as shown in [22]. Moreover, this model was rebuilt using Matlab/Simulink, with some manipulation, as reported in [23].

In this research, the studied power system (i.e., the EPS), which consists of seven strongly tied zones, is carried out based on the NECC. Moreover, interconnection details are not considered. Therefore, the EPS is represented by a single area power system model. The studied power system comprises steam power plants (reheat and non-reheat turbine), gas power stations (non-reheat turbine), hydropower plants and wind farms. The nonlinear model of the EPS considering wind energy with decentralized controllers is represented in Fig. 2. The three subsystems

(i.e., non-reheat, reheat and hydro power plants) are given for the EPS with inherent nonlinearities, i.e., a speed governor dead band (backlash) and GRCs of power plants. Backlash is defined as the total magnitude of sustained speed change where the maximum and minimum limits ( $V_U, V_L$ ) restrict valve opening/closure, while the GRC limits the generation rate of output power, which is given as 0.2 pu MW/min and 0.1 pu MW/min for non-reheat and reheat turbines, respectively. However, the actual GRC of a hydropower plant is about 0.5 pu MW/min, which is higher than the generation rate corresponding to any practical disturbance and hence it will be neglected [1].

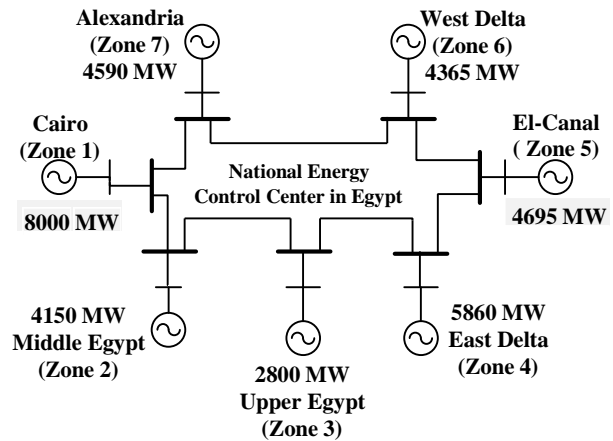

Fig. 1. Typical single-line diagram of Egyptian power system

The EPS parameters that are independent from the system operation are given in Table I. However, the other parameters vary with time depending on the operating conditions. The nominal parameters values are given in Table II.

The dynamic equations of the EPS in Fig. 2 can be derived and written in the state variable form as follows:

$$\dot{x} = Ax + Bu + Cw \quad (1)$$

$$y = Dx + Ew \quad (2)$$

Hence, the complete state-space equations for the EPS can be obtained as in (3).

From the nonlinear model of the EPS in Fig. 2, there are two inputs ( $\Delta P_L$  and  $\Delta P_C$ ), the output is the frequency deviation  $\Delta f$  in the linearized system, considering  $\Delta P_L$  as load disturbance input in this research. Using the data given above, the transfer function of the EPS model  $G(s)$  given by Fig. 2 and the equations of state space

$$\begin{bmatrix} \dot{x} \\ y \end{bmatrix} = \begin{bmatrix} -\frac{1}{2H} & 0 & \frac{1}{2H} & \frac{1}{2H} \\ 0 & 0 & 0 & 0 \end{bmatrix} \begin{bmatrix} x \\ y \\ \Delta P_L \\ \Delta P_C \end{bmatrix} + \begin{bmatrix} 1 \\ 0 \\ 0 \\ 0 \end{bmatrix} \Delta P_L + \begin{bmatrix} 0 \\ 1 \\ 0 \\ 0 \end{bmatrix} \Delta P_C$$



( $m_2$ ),  $V_W$  is the rated wind speed (m/s) and  $C_P$  represents the wind farm, i.e.1200 wind turbine units of 850 kW each beside the conventional generation units. the power coefficient of the rotor blades, which can be

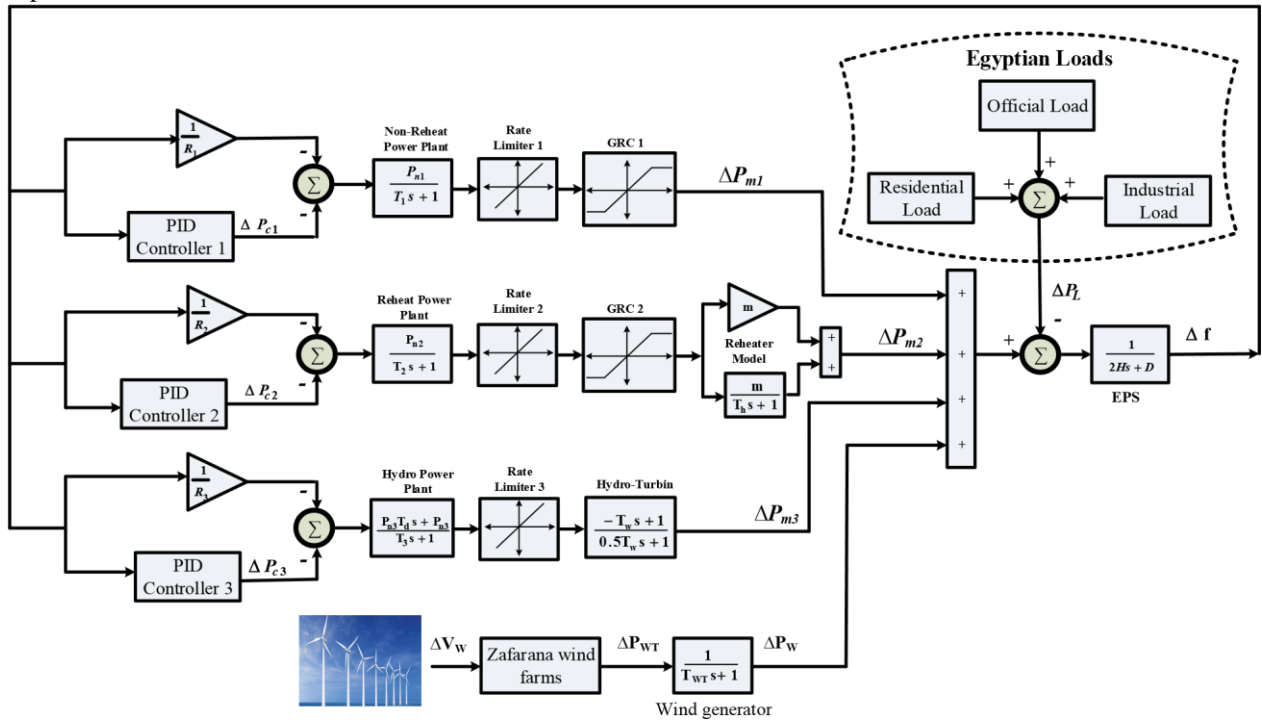

Fig. 2. A nonlinear model of the EPS for seven strongly tied zones considering a wind farm with decentralized controllers

The wind generator is modeled as a first-order transfer function of a unity gain and wind time constant ( $T_{WT}$ ). Therefore, the real output wind power from the wind farm is shown in Fig. 3.

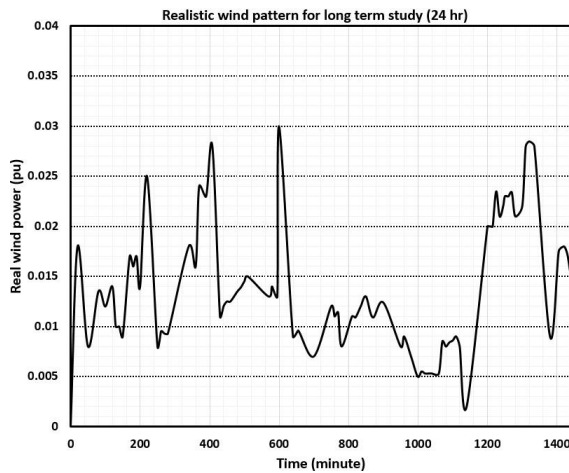

Fig. 3. Dynamic response of real power of the wind farm.

### III. Control Methodology

#### III.1. Conventional PID Controller

In this research, the proposed decentralized control strategy for frequency control is based on the PID

controller, which is one of the earliest industrial controllers. The PID controller is composed of three terms (i.e., gains), which are proportional gain  $K_p$ , integral gain  $K_i$ , and derivative gain  $K_d$ . Its transfer function is expressed as follows:

$$G(s) = K_p + \frac{K_i}{s} + K_d s \quad (6)$$

According to the suffering of the PID controller for finding their optimal parameters, this research uses an intelligent searching method: PSO. It is simple and fast searching intelligent technique modeled to tune the parameters of the PID controller. The main objective of the PSO algorithm is to minimize the system frequency deviation by obtaining the optimal PID controller parameters. Moreover, the integral of squared-error (ISE) is used in this study as an objective function of the optimization technique [17].

#### III.2. Particle Swarm Optimization

The PSO was first introduced by Kennedy and Eberhart in 1995 [25]. It is a global optimization algorithm based on the evolutionary computation technique. The basic operation principle of PSO is developed on a swarm of fish schooling, birds flocking etc. Birds are either dispersed or go together from one place to another for searching their food. Furthermore, one of them can discover the place where food can be found due to the information

transmitted by other birds at any time while searching food [26].

In the PSO algorithm, instead of using evolutionary operators, individuals called particles are used. Therefore, a swarm consists of several particles and each particle represents a potential to the problem. Each particle in PSO flies in the search space according to its own flying experience and its companion flying experience. Each particle is treated as a particle in D-dimension search space. The particle position is represented as  $X_i$  and the best previous position of any particle is recorded; this value is called pbest. Another value that is tracked by a global version of the PSO, which is the overall best value called gbest [27]. The velocity of particle  $i$  is represented by  $V_i$  and all particles are updated according to the following equations:

$$V_i = V_i + c_1 \cdot r_1 \cdot (p_{best} - X_i) + c_2 \cdot r_2 \cdot (g_{best} - X_i) \quad (7)$$

$$X_i = X_i + V_i \quad (8)$$

Eqs. (7) and (8) are used to calculate the new velocity and new position of each particle according to its previous values. In this study, PID controller tuning is considered as an optimization problem handled by the PSO algorithm. Here, each particle in the search space introduced a probable solution for PID gains ( $K_p, K_i, K_d$ ), which are a 3-dimensional problem. The performance of the probable solution point is determined by a fitness function which consisting of several component functions. These components are a steady-state error ( $E_{ss}$ ), peak overshoot ( $M_p$ ), rise time ( $Tr$ ) and settling time ( $T_s$ ). The selection of PSO parameters decides to a great extent the ability of global minimization. Therefore, according to the trials, the PSO algorithm parameters are given in Table III, which are used for verifying the performance of PSO-PID. In this research, the intelligent based PID controller has been applied to the LFC issue of the EPS considering wind energy using PSO algorithm as decentralized and centralized control schemes.

TABLE III  
PSO PARAMETERS

Parameter	$n$	$c_1$	$c_2$	$w$
Value	50	0.12	1.2	0.9

The EPS has three dynamic subsystems: non-reheat, reheat, and hydro power plants. In addition, wind energy is integrated into the EPS. The response of each subsystem is different from each other. Therefore, the optimal decentralized PID controller based on PSO algorithm has been designed for every subsystem separately to regulate the frequency and to track the load. The obtained values of decentralized PID controllers'

parameters based on the PSO technique are given in Table IV.

TABLE IV  
DECENTRALIZED PID CONTROLLERS' PARAMETERS  
FOR EVERY SUBSYSTEM

Type of subsystem	PID Parameter		
	$K_p$	$K_i$	$K_d$
Non-Reheat power plant	26.5370	16.3125	-0.5080
Reheat power plant	9.68204	0.806941	18.73075
Hydro power plant	38.5370	18.1430	0.1

The optimal centralized PID controller-based PSO is used to make a fair comparison with the optimal decentralized model for stabilizing EPS frequency considering wind energy. Moreover, the main idea behind combining the three controllers in one centralized controller is to simplify the optimization process and to compare the performance of both schemes. The obtained values of the centralized PID controllers based on PSO technique are given in Table V.

TABLE V  
CENTRALIZED PID CONTROLLERS' PARAMETERS  
FOR THE OVERALL SYSTEM

Overall EPS	PID Parameter		
	$K_p$	$K_i$	$K_d$
Centralized Controller	71.2532	5.9055	6.10758

#### IV. Simulation Study

The designed controllers based on PSO algorithm are applied to regulate the system frequency of the EPS, which comprises three dynamic subsystems; non-reheat, reheat, and hydro power plants, as well as wind energy. In this research, the decentralized LFC scheme is compared to the centralized one for the EPS and considering the effect of system non-linearity. The simulation results and analysis are carried out using Matlab/Simulink software®, which took into account the GRCs of different generation sources into account. A literature survey shows that many researches in the area of LFC problem assume that load disturbance is a step change disturbance, which represents the forced outage of a generation unit or the sudden switch off of a massive load. However, in fact, the load disturbances are complex and have random nature. Therefore, different patterns of load disturbances, wind power fluctuations and system parameters variation (i.e., system uncertainty) are applied to the proposed control schemes of the Egyptian LFC to validate that the centralized design is more robust in case of low disturbance. However, the decentralized control scheme gives a reliable performance under large variation in load conditions and wind power uncertainties.



## V. Simulation Results and Discussion

The detailed model of the EPS considering wind energy is built using Matlab/ Simulink model. Moreover, the code of the PSO algorithm (i.e., M-file) is interfaced with the EPS model to perform the optimization process. The dynamic response of the studied power system with the control schemes is obtained and evaluated under different operating conditions through the following scenarios.

### V.1. Scenario 1: Conventional Load Patterns

In this scenario, different conventional load patterns are applied to the EPS without the wind energy using the two proposed control schemes, which are based on PSO algorithm. The EPS performance with the proposed decentralized controllers based on PSO algorithm is tested and compared with the system performance with a centralized controller based on the same optimization technique. This comparison is evaluated under different load patterns as the follows:

**Case A:** in this case, the EPS with the proposed control schemes are tested by implementation different patterns of step load disturbances. The dynamic responses of each subsystem (i.e., non-reheat, reheat and hydro power plant) in case of nominal system parameters are shown in Fig. 3. It is clear that the dynamic response of each subsystem is different than the others.

Therefore, the authors propose the modern design of a

decentralized controller for each subsystem independently to guarantee the stability of the overall closed-loop system. Fig. 4 shows the dynamic response of the EPS for the studied cases 1 and 2. It has been noticed that the model of decentralized controllers based on PSO algorithm is more robust and has a fast response to all disturbance cases compared to the centralized model. Moreover, the centralized controller design cannot handle large disturbance. The performance specifications, maximum overshoot (MOS), maximum undershoot (MUS) and maximum settling time ( $T_s$ ) of the studied system with the proposed control schemes of case A during the whole period of simulation (5 minutes) have been compared in Table VI.

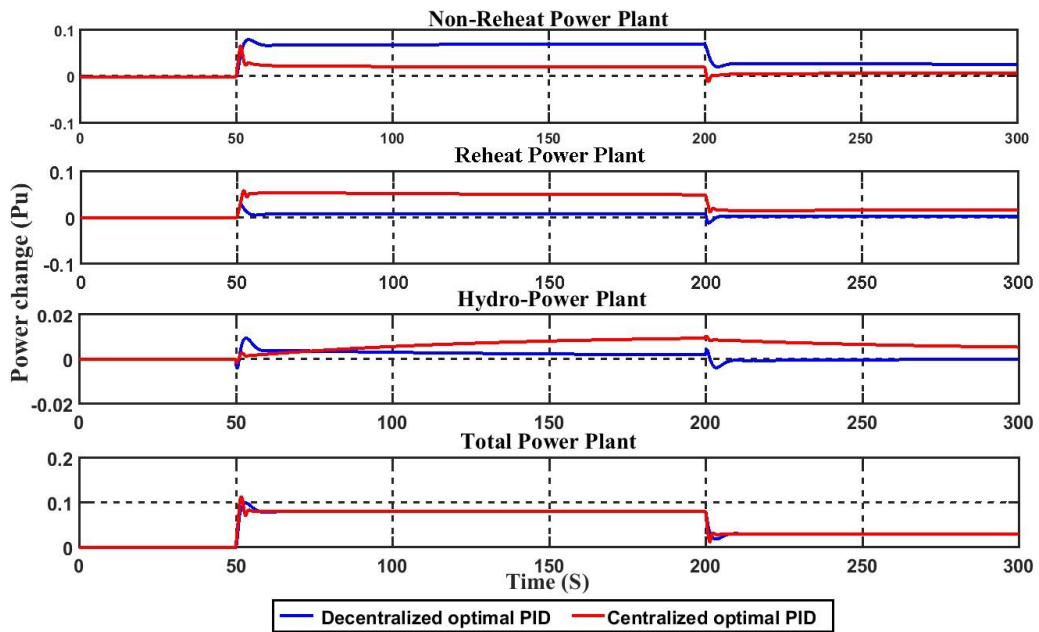

Fig. 3. The response of different Power plants for LFC problem of the EPS for case no.1 of Scenario A

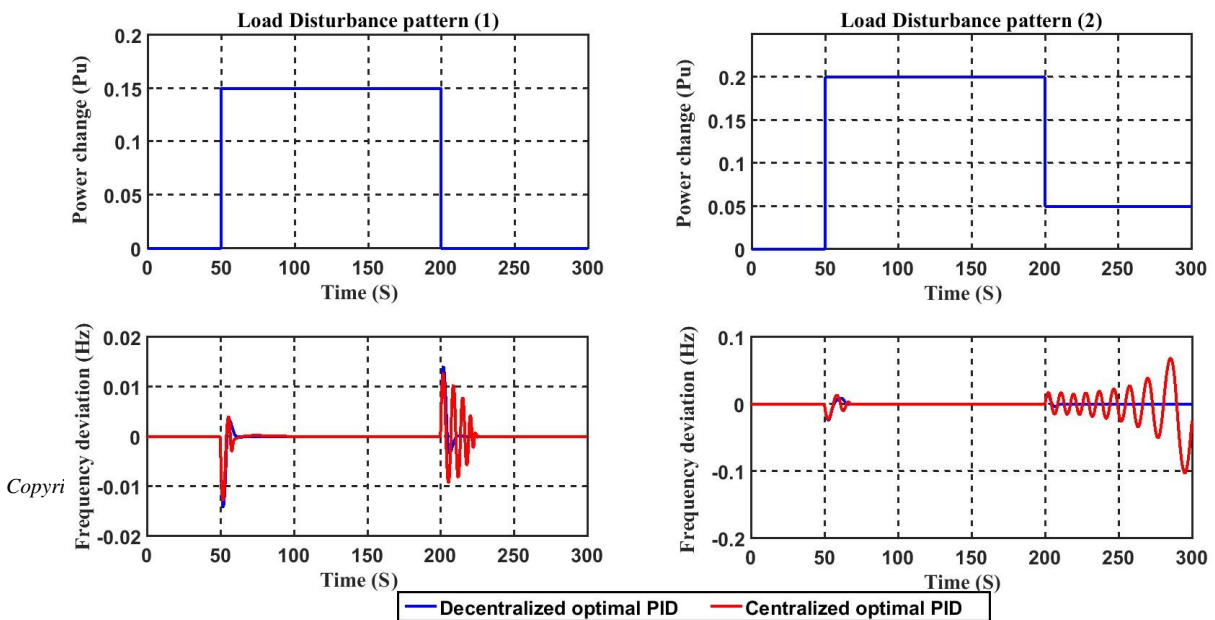

Fig. 4. The frequency deviation of the EPS of Scenario 1-Case A

TABLE VI  
PERFORMANCE SPECIFICATION OF THE EPS FOR SCENARIO 1, CASE A

	Case A	Decentralized Control strategy	Centralized Control strategy
1	MUS (pu)	0.01403	0.01277
	MOS (pu)	0.01410	0.01280
	$T_s$ (s)	17.412	43.585
2	MUS (pu)	0.02360	0.1020
	MOS (pu)	0.01381	0.06823
	$T_s$ (s)	20.182	-

**Case B:** the comparison between the two-model is represented by using a series of step load changes with

random magnitudes to test the robustness and effectiveness of the proposed decentralized controllers.

From Fig. 5, it is clear that the dynamic response of the centralized control design oscillates to such an extent that it is not satisfactory. In contrast, it gives a satisfactory performance in case of applying slight load change. Although the proposed decentralized control model gives a little larger overshoot than the centralized control model in some cases, it gives robust stability and has faster settling time than the centralized model. The performance specifications, i.e. MOS, MUS and  $T_s$  of the studied system with proposed control schemes of case B during the whole period of simulation (5 minutes) have been compared in Table VII.

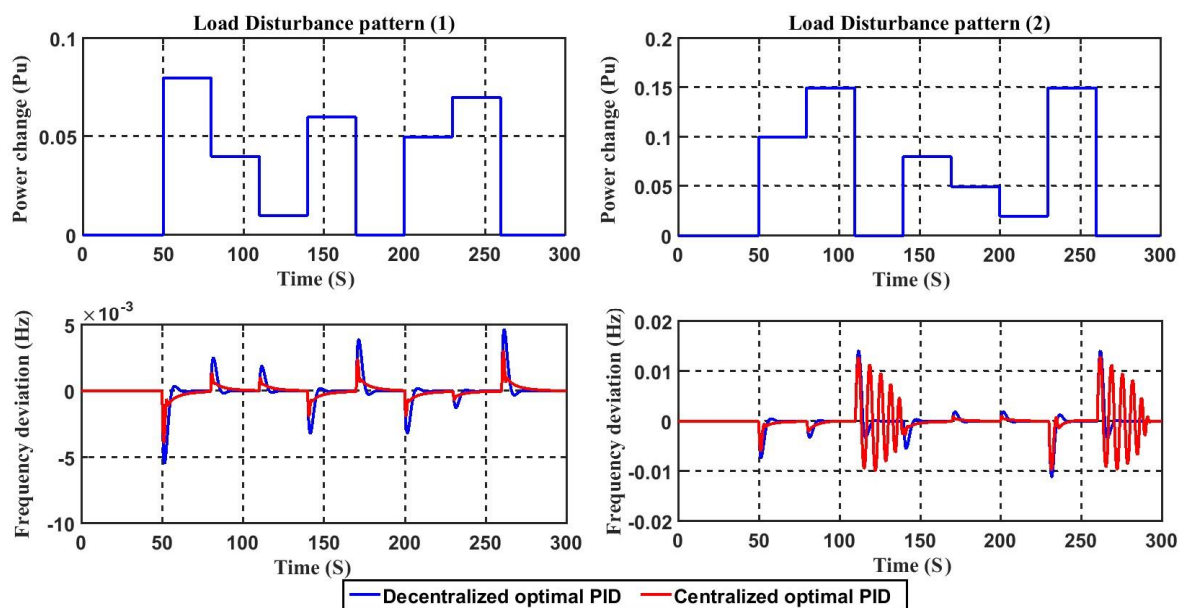

Fig. 5. The frequency deviation of the EPS of Scenario 1-Case B

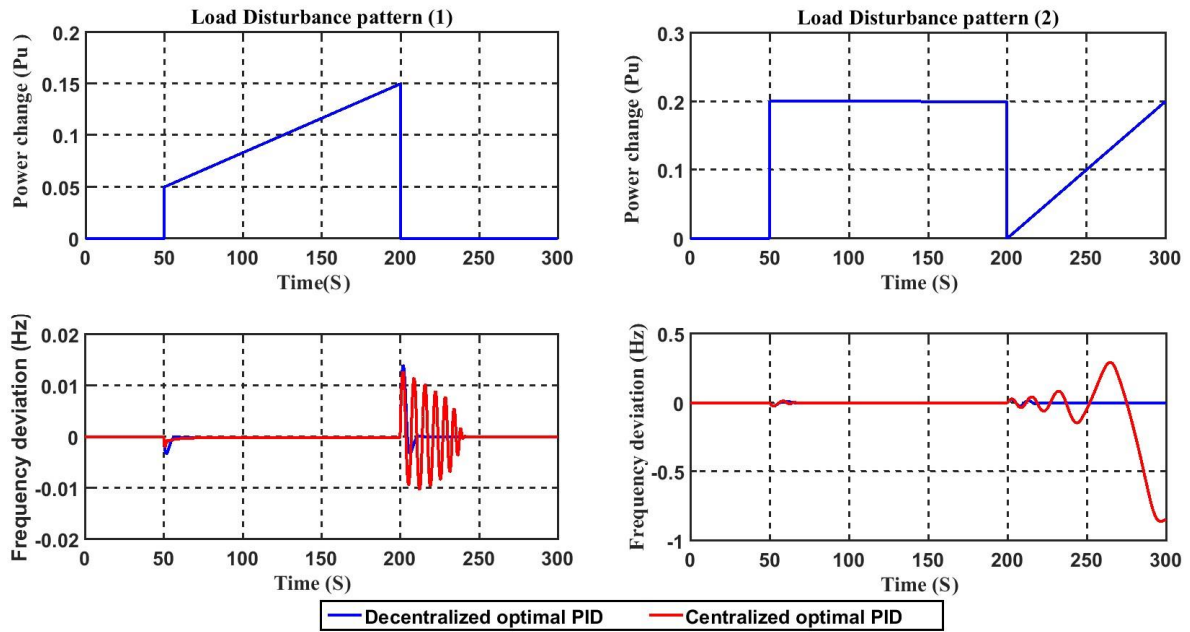

Fig. 6. The frequency deviation of the EPS of Scenario 1-Case C

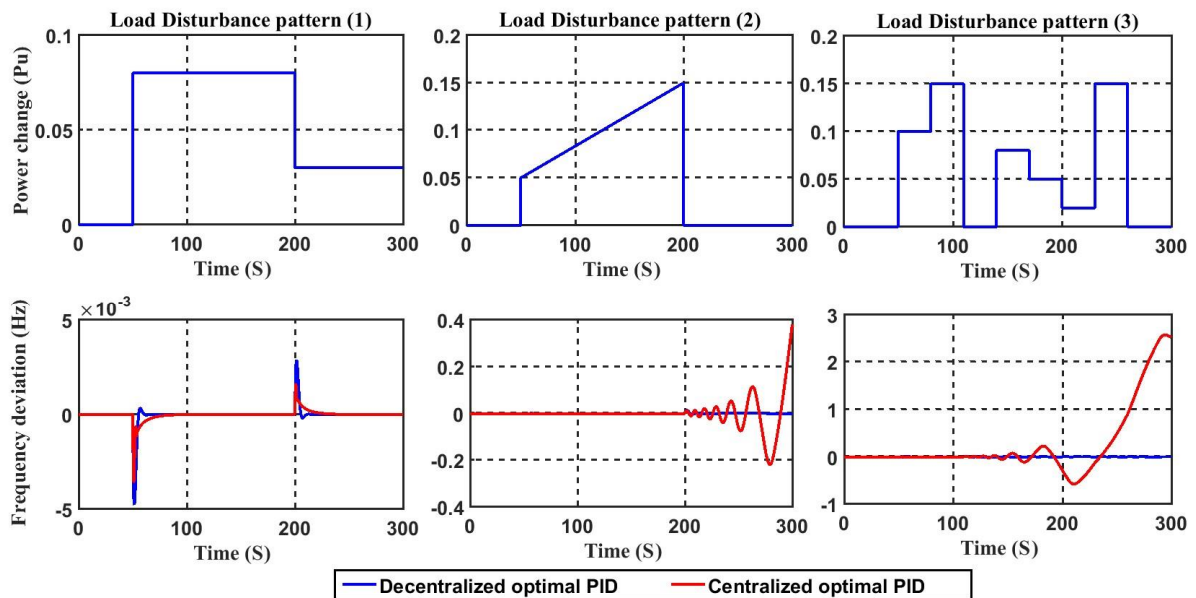

Fig. 7. The frequency deviation of the EPS of Scenario 1-Case D

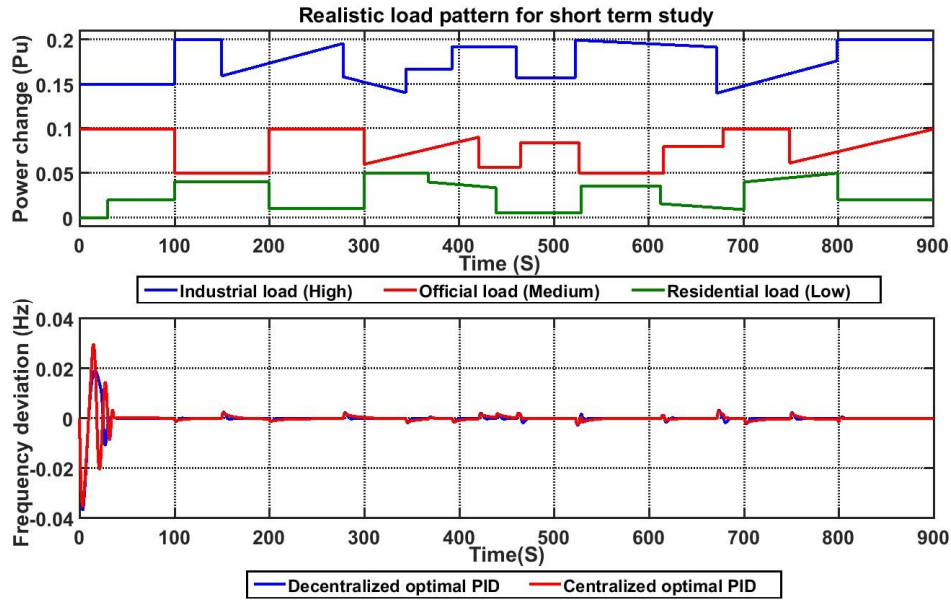

Fig. 8. The frequency deviation of the EPS of Scenario 2

TABLE VII  
PERFORMANCE SPECIFICATION OF THE EPS FOR SCENARIO 1, CASE B

Case B		Decentralized Control strategy	Centralized Control strategy
1	MUS (pu)	0.005424	0.003854
	MOS (pu)	0.01001	0.003036
	$T_s$ (s)	13.701	36.212
2	MUS (pu)	0.0111	0.010913
	MOS (pu)	0.01408	0.01285
	$T_s$ (s)	16.576	37.076

**Case C:** In this case, the ramping of load change for different patterns have been applied to the EPS to evaluate the performance of two-control schemes. The simulation results concluded that favorable results have been obtained from the proposed decentralized control scheme as seen in Fig. 6, while the dynamic response of the centralized model oscillates to such an extent that it is not acceptable. The performance specifications, i.e. MOS, MUS, and  $T_s$  of the studied system with proposed control schemes of case C during the whole period of simulation (5 minutes) have been compared in Table VIII.

TABLE VIII  
PERFORMANCE SPECIFICATION OF THE EPS FOR SCENARIO 1, CASE C

Case C		Decentralized Control strategy	Centralized Control strategy
1	MUS (pu)	0.003181	0.01018
	MOS (pu)	0.01396	0.01268
	$T_s$ (s)	16.644	42.925

2	MUS (pu)	0.02379	0.8605
	MOS (pu)	0.02282	0.2923
	$T_s$ (s)	28.189	-

**Case D:** in this scenario, the influence of system parameters variations (i.e., system uncertainty) is studied to validate the effectiveness of the proposed control scheme. Therefore, the EPS is tested under a new operation condition, as reported in Table IX. Here, the equivalent inertia constant of the overall system is calculated as in Eq. (9) [28]:

$$= \frac{\sum_{i=1}^{np} N(i) \cdot UNIR(i) + R_L \cdot T_L \cdot P_{lo}}{P} \quad (9)$$

In this case, the EPS with the proposed two-model has been tested for three different load patterns as seen in Fig. 7. It is clear that the proposed model of decentralized controllers based on PSO algorithm achieved a robust stability against system uncertainties, while the system response with the centralized control model oscillates violently, in contrast, it gives a satisfactory response to small disturbances. The performance specifications of the proposed two-control model for this case have been compared in Table X.

TABLE IX  
TWO OPERATION CONDITIONS OF THE EPS

Parameter	H	$P_{n1}$	$P_{n2}$	$P_{n3}$
Case D	6.1452	0.3335	0.5455	0.1210
Base value	5.7096	0.2529	0.6107	0.1364

V.2. Scenario 2: Realistic/Modern Load Pattern for Short-Term Study

In this scenario, The EPS with the proposed control schemes is tested and evaluated under a realistic load pattern for short-term study (i.e., 15 minutes). The combination of both step load change, which represents the forced outage of the generation unit or the sudden switch offload, and ramp load change, which represents industrial load produces a random change in the load, creates a realistic load pattern.

TABLE X  
PERFORMANCE SPECIFICATION OF THE EPS FOR SCENARIO 1, CASE D

Case D		Decentralized Control strategy	Centralized Control strategy
1	MUS (pu)	0.004756	0.003519
	MOS (pu)	0.002797	0.001612
	T <sub>s</sub> (s)	15.982	44.684
2	MUS (pu)	0.005434	0.2181
	MOS (pu)	0.01279	0.3816
	T <sub>s</sub> (s)	18.764	-
3	MUS (pu)	0.009987	0.578
	MOS (pu)	0.01289	2.576
	T <sub>s</sub> (s)	16.461	-

like MOS, MUS, and T<sub>s</sub> of the EPS with the proposed control schemes of this scenario during short-term simulation study (15 minutes) have been compared in Table XI.

TABLE XI  
PERFORMANCE SPECIFICATION OF THE EPS FOR SCENARIO 2.

Scenario 2	Decentralized Control strategy	Centralized Control strategy
MUS (pu)	0.03648	0.0359
MOS (pu)	0.01873	0.0295
T <sub>s</sub> (s)	32.5	41.715

### V.3. Scenario 3: Realist/Modern Load and Wind Power Patterns for Long-Term Study

In this scenario, the effectiveness and robustness of the proposed decentralized scheme are evaluated by implementing a realistic load (i.e., industrial, official and residential loads) and wind power patterns for long-term study (i.e., 24 hours). The real wind speed data extracted from Zafarana location in Egypt is used as reported in [16]. Moreover, the real wind power output from an aggregated model of the wind farm is illustrated in Fig. 3. It is clear that the real wind power randomly fluctuates due to the nature of wind speed in Zafarana location.

Fig. 9 shows the frequency deviation of the EPS with

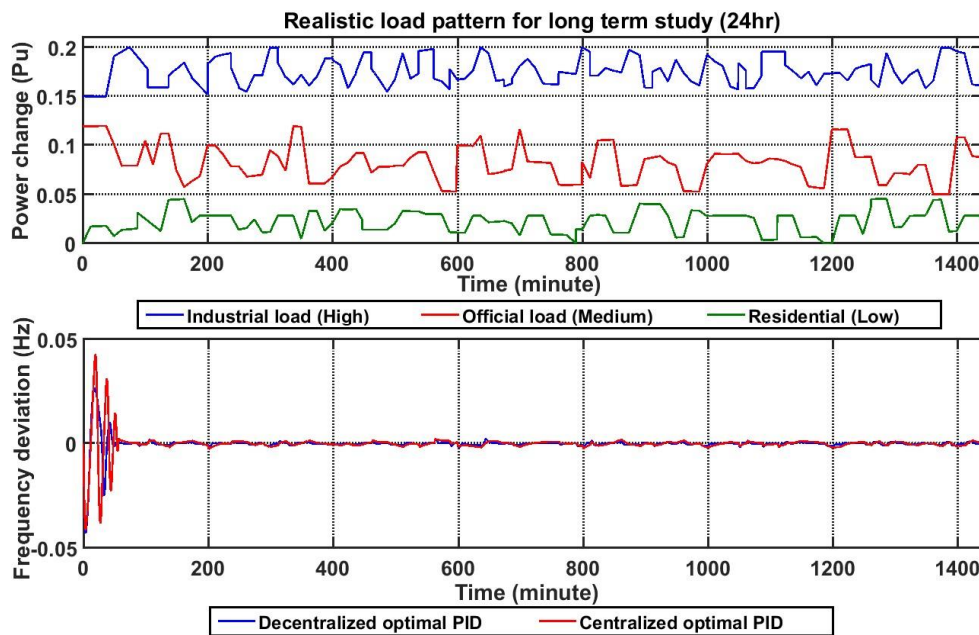

Fig. 9. The frequency deviation of the EPS of Scenario 3

Therefore, realist load is considered as a combination of high random load change (i.e., industrial load), medium random load change (i.e., official load) and low random load change (i.e., Residential load). Fig. 8 shows that the frequency response of the EPS is affected by the random changes of a realistic load, while the dynamic response of the proposed decentralized control model gives a reliable performance in terms of maintaining the frequency and yields small frequency transient compared to the centralized control model. The performance specifications

the control schemes under the effect of realistic load and wind power pattern for full one day. According to the European network of transmission system operators for electricity codes [29], the standard frequency range is  $\pm 0.2$  Hz, the maximum instantaneous frequency deviation is 0.8 Hz, the maximum steady-state frequency deviation is 0.5 Hz and time to recover frequency is 1 min for the LFC of the power system of a 50 Hz nominal frequency. Although the decentralized control model gives some

minor fluctuations, it is within acceptable ranges compared to the centralized control model. The system performance specifications of this scenario have been compared in Table XII.

TABLE XII  
PERFORMANCE SPECIFICATION OF THE EPS FOR SCENARIO 3

Scenario 3	Decentralized Control strategy	Centralized Control strategy
MUS (pu)	0.0426	0.04108
MOS (pu)	0.02628	0.04228
T <sub>s</sub> (s)	46.876	82.6920

## VI. Conclusion

This research has presented a decentralized LFC design for the EPS using an optimal PID controller-based PSO algorithm. The EPS includes both conventional generation units, which are decomposed into three dynamic subsystems (i.e., non-reheat, reheat and hydro power plants) and wind energy, which is extracted from Zafarana wind farm located at the edge of the Red Sea in Egypt. The performance of the proposed decentralized LFC model (i.e., subsystem controller) is tested and compared to the centralized model under variation in loading patterns, loading conditions, system parameters and wind farm penetration. The EPS with the proposed control schemes has been tested and evaluated by using Matlab/SIMULINK software®. The simulation results have shown that the dynamic response of the EPS with the proposed decentralized control strategy is faster and better damped than when using the centralized control strategy. On the other hand, the centralized controller gives a satisfactory performance respect to the proposed decentralized model in case of applying a slight load change. In contrast, it oscillates to such an extent that it is not satisfactory in case of applying large load disturbance.

## Appendix

Wind Turbine model: manufacturer: GAMESA (Spain), model: G52/850, rated power: 850 kW, rotor diameter: 52 m, swept area: 2.124 m<sup>2</sup>, Cut-in wind speed 4 m/s, Rated wind speed 16 m/s, Cut-off wind speed 25 m/s, maximum generator output speed 1900 rpm, and output voltage 690 V.

## References

- [1] H. Bevrani, *Robust Power System Frequency Control* (New York, Springer, 2nd edition, 2014).
- [2] T. Kerdphol, F. S. Rahman, Y. Mitani, k. Hongesombut, S. Kufeoglu, Virtual Inertia Control-Based Model Predictive Control for Microgrid Frequency Stabilization Considering High Renewable Energy Integration, *Sustainability*, vol. 9 n. 5, 2017, pp. 1-21.
- [3] P. Kundur, *Power System Stability and Control* (New Delhi: Tata McGraw-Hill Education, 5th reprint, 2008).
- [4] Y. Sun, Y. Wang, Z. Wei, G. Sun, X. Wu, Robust H load frequency control of multi-area power system with time delay: A sliding mode control approach, *IEEE/CAA Journal of Automatica Sinica*, vol. 5 n. 2, 2018, pp. 1-8.
- [5] H. Yousef, Adaptive fuzzy logic load frequency control of multi-area power system, *Electrical power and Energy Systems*, vol. 68 n. 1, 2015, pp. 384-395.
- [6] S. H. Shahalami, D. Farsi, Analysis of Load Frequency Control in a restructured multi-area power system with the Kalman filter and the LQR controller, *International Journal of Electronics and Communications*, vol. 86 n. 1, 2018, pp. 25-46.
- [7] Raheel Ali, Tarek Hasan Mohamed, Yaser Soliman Qudaih, Y. Mitani, A new load frequency control approach in an isolated small power system using coefficient diagram method, *International Journal Electrical Power and Energy Systems* vol. 56 n. 1, 2014, pp. 110-116.
- [8] P. Garasi, Y. Qudaih, R. Ali, M. Watanabe, Y. Mitani, Coefficient Diagram Method Based Load Frequency Control for a Modern Power System, *Journal of Electronic Science and Technology*, vol. 12 n. 3, 2014, pp. 270-276.
- [9] T.H. Mohamed, G. Shabib, H. Ali, Distributed load frequency control in an interconnected power system using ecological technique and coefficient diagram method, *International Journal Electrical Power and Energy Systems* vol. 82 n. 1, pp. 110-116, 2016.
- [10] A.B. Kunya, M. Argin, Model Predictive Load Frequency Control of Multi-Area Interconnected Power System, *IEEE Conf., Texas Power, and Energy Conference (TPEC)-College Station~ February 8-9, 2018, TX, USA.*
- [11] G. Shabib, E.H. Abd-Elhamed, G. Magdy, Robust Digital Redesign of Continuous PID Controller for Power System Using Plant-Input-Mapping, *WSEAS TRANSACTIONS on POWER SYSTEMS*, vol. 13 n. 1, 2018, pp. 31-39.
- [12] H. Illias, A. Fikri, M. Zahari, H. Mokhlis, Optimisation of PID controller for load frequency controller in two-area power system using evolutionary particle swarm optimisation, *International Journal Electrical Systems* vol. 12 n. 2, 2016, pp. 315-324.
- [13] M. Gheisarnejad, An effective hybrid harmony search and cuckoo optimization algorithm based fuzzy PID controller for load frequency control, *Applied Soft Computing*, vol. 65 n. 1, 2018, pp. 121-138.
- [14] G. El-Saddy, E.A. Ibrahim, A.A. Donkol, Ant Colony PID Controllers for Nonlinear Load Frequency Control System, *International Journal on Power Engineering and Energy (IJPEE)*, vol. 8 n. 1, 2017, pp. 719-724.
- [15] S. saxena, Y.V. Hote, Decentralized PID Load Frequency Control for perturbed multi-area power systems, *International Journal of Electrical Power & Energy Systems*, vol. 81 n. 1, 2016, pp. 405-415.
- [16] H.M. Hasanien, A.A. El-fergany, Symbiotic organisms search algorithm for automatic generation control of interconnected power systems including wind farms, *IET Gener. Transm. Distrib.*, vol. 11 n. 7, 2017, pp. 1692-1700.
- [17] H.M. Hasanien, whale optimization algorithm for obtaining the optimal PID controller parameters in interconnected modern power system including renewable sources, *IET Gener. Transm. Distrib.*, vol. 12 n. 3, 2017, pp. 607-616.
- [18] M. Ma, X. Liu, C. Zhang, LFC for multi-area interconnected power system concerning wind turbines based on DMPC, *IET Gener. Transm. Distrib.*, vol. 11 n. 10, 2017, pp. 2689-2696.
- [19] H. Wang, Z. Chen, Q. Jiang, Optimal control method for wind farm to support temporary primary frequency control with minimized wind energy cost, *IET Renew. Power Gener.*, vol. 9 n. 4, 2015, pp. 350-359.
- [20] Global Wind Energy Council (GWEC), Global wind report annual market update 2018, available at <http://www.gwec.net>
- [21] Global market outlook for photovoltaics 2014-2018, available at <http://www.pvresources.com>
- [22] Egyptian Electricity Holding Company, *Annual Report of 2014-2015*, available at <http://www.eehc.gov.eg/eehcportal/YearlyReports.aspx>
- [23] G. Magdy, A. Bakeer, G. Shabib, A.A. Elbaset, Y. Mitani, Decentralized Model Predictive Control Strategy of a Realistic Multi Power System Automatic Generation Control, *IEEE Conf., 16th International Middle East Power Systems Conference*

- (MEPCON'19) ~ December 19-21, 2017, Menoufia University, Egypt, pp. 190-196.
- [24] The Wind Power, *Wind energy database*, available at [https://www.thewindpower.net/turbine\\_en\\_42\\_gamesa\\_g52-850\\_p hp](https://www.thewindpower.net/turbine_en_42_gamesa_g52-850_p hp)
- [25] J. Kennedy, R. Eberhart, Particle Swarm Optimization, *IEEE International Conference on Neural Networks, Perth, Australia, vol. 4 n. 1*, 1995, pp. 1942-1948.
- [26] T. Kerdphol, Y. Qudaih, Y. Mitani, Optimum battery energy storage system using PSO considering dynamic demand for microgrids, *Electrical Power and Energy Systems, vol. 83 n. 1*, 2016, pp. 58-66.
- [27] G. Magdy, A. Bakeer, G. Shabib, A.A. Elbaset, Y. Mitani, Discrete-time optimal controller for load frequency control of multi-source power system in Egypt, *IEEE Conf., Innovative Trends in Computer Engineering (ITCE)-February 19-21, 2018, Aswan, Egypt*.
- [28] J. Nanda, S. Mishra and L. C. Saikia, Maiden Application of Bacterial Foraging-Based Optimization Technique in Multiarea Automatic Generation Control, *IEEE Trans. on Power system, vol. 24 n. 2*, 2009, pp. 602-609.
- [29] European Network of Transmission System Operators for Electricity (entsoe), *Supporting Document for the Network Code on Load-Frequency Control and Reserves*, chapter 4, 2013, pp. 17-36.
- [30] Hasanien, H., Muyeen, S., Benbouzid, M., Optimal Control of a One-Area LFC System Including Time Delay Using Shuffled Frog Leaping Algorithm, (2017) *International Journal on Energy Conversion (IRECON)*, 5 (5), pp. 130-134.

### Authors' information

<sup>1</sup> Department of Electrical and Electronics Engineering, Kyushu Institute of Technology (KIT), Fukuoka, 804-8550, Japan.

E-mail: [gabermagdy100@gmail.com](mailto:gabermagdy100@gmail.com)

<sup>2</sup> Department of Electrical Engineering, Faculty of Energy Engineering, Aswan University, Aswan 81528, Egypt.

<sup>3</sup> Higher Institute of Engineering and technology, King Marriott, Alexandria 23713, Egypt.

<sup>4</sup> Department of Electrical Engineering, Faculty of Engineering, Minia University, Minia 61517, Egypt.

<sup>5</sup> Electrical Engineering Department, American University, Madaba, Jordan.

<sup>6</sup> Electrical and Computer Engineering Department, University of Kurdistan, Sanandaj, Iran.



**G. Magdy** was born in Qena, Egypt, in 1989. He received the B.Sc. and M.Sc. degrees in electrical engineering at the Faculty of Energy Engineering, Aswan University, Egypt, in 2011 and 2014, respectively, and is currently pursuing the Ph.D. degree in the Department of Electrical and Electronics Engineering, Graduate School of

Engineering, Kyushu Institute of Technology, Kitakyushu, Japan. In 2012, he joined the Department of Electrical Engineering, Faculty of Energy Engineering, Aswan University, Aswan, Egypt, first as demonstrator and then becoming Assistant lecturer in 2014. His research interests include power system stability, advanced control of power system and digital control techniques, all applied to power systems in addition to renewable energy applications.



**G. Shabib** received his B.Sc. degree in electrical engineering from Al Azhar University. In October 1982, he joined the electrical engineering department, King Fahad University of Petroleum and Minerals, Dhahran Saudi Arabia as research assistant. In December 1985, he received his M.Sc. degree in electrical engineering at King Fahad

University of Petroleum and Minerals. In November 1987, he joined Qassim Royal Institute, Qassim, Saudi Arabia as lecturer. He received his Ph.D. degree from Menoufia University, Egypt, in 2001. He joined Aswan High Institute of Energy, South Valley University, Aswan, Egypt in 1999. He joined Digital Control Laboratory, Tsukuba University, Japan as visiting Professor in 2006–2007. His research interests are power system stability, control, Self-tuning control, Fuzzy logic techniques, digital control techniques, all as applied to power systems.



**Adel A. Elbaset** was born in Nag Hamadi, Qena-Egypt, on October 24, 1971. He received the B.Sc., M.Sc., and Ph.D. at the Faculty of Engineering, Department of Electrical Engineering, Minia University, Egypt, in 1995, 2000 and 2006, respectively. He is a staff member of the Faculty of Engineering,

Electrical Engineering Dept., Minia University, Egypt. He was visiting assistant professor at Kumamoto University, Japan, until August 2009. Presently, he is Professor at the Department of Electrical Engineering. His research interests are in the area of power electronics, power system, neural network, fuzzy systems and renewable energy and Optimization.

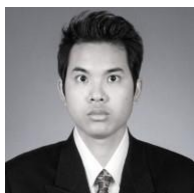

**Thongchart Kerdphol** received his B.Eng. and M.Eng at Kasetsart University, Bangkok, Thailand, in 2010 and 2012. Currently, he is a Ph.D. student sponsored by the Japan Student Services Organization (JASSO honors scholarship) and Kyushu Institute of Technology (100<sup>th</sup> Anniversary scholarship) at Mitani laboratory, KIT. His research interests

are in the area of analysis and design of power systems, dynamics and controls.



**Yaser Qudaih** Graduated from the University of Engineering and Technology, Lahore, Pakistan, in 1996, as an electrical engineer. He Completed his M.Sc. and Ph.D. at Kumamoto University, Japan, in Electrical Engineering. He worked as Project Assistant Professor at the Department of Electrical Engineering and Electronics, Kyushu

Institute of Technology (KIT), Japan. Currently, he is assistant professor at the American University of Madaba (AUM) in Jordan and the chair of the Innovation program at AUM. His areas of interest include renewable energy power systems and Smart Grid Applications. He is a member of the Institute of Electrical Engineers of Japan and of IEEE.





**Hassan Bevrani** (S'90–M'04–SM'08) received the Ph.D. degree in electrical engineering at Osaka University, Osaka, Japan, in 2004. From 2004 to 2014, he has worked as Postdoctoral Fellow, Senior Research Fellow, Visiting Professor and Professor at Kumamoto University, Japan, Queensland University of

Technology, Australia, Kyushu Institute of Technology, Japan, Ecole Centrale de Lille, France and Osaka University. He is currently working as Professor at the University of Kurdistan, Iran. He has authored five books, ten book chapters, and over 200 journal/conference papers. His current research interests include smart grid control, robust power system monitoring and control and microgrid dynamics and control.



**Yasunori Mitani** received B.Sc., M.Sc., and D.Eng. degrees in Electrical Engineering at Osaka University, Japan in 1981, 1983 and 1986, respectively. He was visiting research associate at the University of California, Berkeley, from 1994 to 1995. He is currently professor at the department of electrical and electronics engineering, Kyushu Institute of

Technology (KIT), Japan. At present, he is the head of environmental management center of KIT and vice dean of a graduate school of engineering, KIT.

